



Operation instructions manual
netANALYZER Scope
Data acquisition and analysis
V2.10

Hilscher Gesellschaft für Systemautomation mbH
www.hilscher.com

DOC131002OI09EN | Revision 9 | English | 2019-03 | Released | Public

Table of contents

1	Introduction	5
1.1	About this manual	5
1.1.1	List of revisions	5
1.1.2	Conventions in this manual	6
1.2	Contents of the product DVD	7
1.2.1	Directory structure of the DVD	7
1.3	Legal notes	8
1.4	Registered trademarks	12
2	Fundamentals	13
2.1	Addressed users and usage	13
2.2	Recording and analyzing data traffic	13
2.3	Functional overview	16
2.4	Licensing	18
2.4.1	Licensing for single functionalities	18
2.4.2	License Manager	19
2.4.3	License model	19
2.5	Timestamps	20
2.6	Installing the netANALYZER Scope software	21
3	Graphical user interface	22
3.1	Start screen	22
3.1.1	Select language	23
3.2	Side menu	24
3.2.1	The main menu	25
3.3	Message output area	31
3.4	Status bar	32
4	Configuring netANALYZER Scope	33
4.1	Menu Device assignment	34
4.1.1	Assigning a device	40
4.2	Menu „Options“	42
4.2.1	Settings for autonomous operation	43
4.2.2	Recording settings	44
4.2.3	Indicators	47
4.3	Filter settings for hardware filters	48
4.3.1	Dialog structure and user interface elements	48
4.3.2	Ethernet Frame Filter	51
4.3.3	Predefined filters	52
4.3.4	Individually defined filters	53
4.3.5	Context menu functions	55
4.3.6	Defining and storing filter settings	55
5	Recording Data	58
5.1	Define triggers to stop recording	60
6	Project administration	61
6.1	Create a new project	62

6.2	Save an existing project	64
6.2.1	Save option	64
6.3	Load a saved project	65
6.4	The configuration assistant	69
7	Analyzing EtherCAT frames	72
7.1	EtherCAT datagram structure	73
7.2	Definition of signal directions	74
7.3	List of EtherCAT commands	75
7.4	List of supported data types for variables	76
7.5	List of EtherCAT Items	77
8	Analyzing PROFINET frames	78
8.1	List of supported data types for PROFINET variables	78
8.2	Start-up of PROFINET communication	79
8.3	Communication events	80
9	Analyzing EtherNet/IP frames	83
9.1	List of supported data types for EtherNet/IP variables	83
9.2	Start-up of EtherNet/IP communication	84
9.3	Automatic configuration	85
9.4	Solution strategies for the manual configuration in special cases	86
9.4.1	Special cases	86
9.4.2	Solution strategies	87
10	Using views for analysis	90
10.1	Working with the item list view	91
10.1.1	Open a new item list view	91
10.1.2	General dialogs of the context menu	94
10.1.3	Dialogs of the context menu for EtherCAT	100
10.1.4	Dialogs of the context menu for PROFINET	110
10.1.5	Dialogs of the Context Menu for EtherNet/IP	128
10.1.6	Dialogs of the context menu for custom value filters	142
10.2	Quicktester events	153
10.3	Defining a timing variable	155
10.4	Defining a rate variable	159
10.5	Editing filter conditions	161
10.5.1	Example - Create filter condition for a rate variable	164
10.5.2	Frame quicktester	167
10.6	Display data	169
10.6.1	Open a new view	170
10.6.2	Assigning items to the data recording view	170
10.6.3	Controls in window bar	173
10.6.4	Scaling of time axis and value axis/Scroll bar	179
10.6.5	Configuring the display area for recorded data	180
10.6.6	Performance considerations	192
10.7	Working with the notepad view	193
10.7.1	Open a new notepad view	193
10.8	Trigger view	194

10.8.1	Structure of the trigger view window	195
10.8.2	Window bar of trigger window	196
10.8.3	Configuration area	200
10.8.4	The graphical editor area	201
10.8.5	Sources area.....	202
10.8.6	Functional blocks area	208
10.9	Quick-tester view.....	221
10.9.1	Register cards of quicktester view	222
10.9.2	Functions of quicktester view.....	232
11	Examples for the possibilities of the timing analysis	242
12	Tools	245
12.1	PCAP export	245
12.2	PCAP import	247
12.3	PDF report.....	251
13	Correct errors.....	252
13.1	Error Messages.....	252
13.2	Other error situations	253
13.3	Chart data are displayed incorrectly for EtherCAT.....	254
14	Appendix.....	256
14.1	Addressing of devices across multiple CIP networks using port segments	256
14.2	References.....	257
	List of figures	258
	List of tables.....	264
	Contacts.....	267

1 Introduction

1.1 About this manual

This manual contains a description of the installation and usage of the software netANALYZER Scope for all devices of the netANALYZER series.

1.1.1 List of revisions

Index	Date	Version	Revision
6	2017-05-19	2.6	Document has completely been revised Custom value filters Trigger view reworked, new trigger types Notebook view PCAP import Many context menu dialogs new or reworked
7	2018-02-05	2.8	Section <i>Licensing for single functionalities</i> [▶ page 18]: Quickteste licence added in table Section <i>Quicktester events</i> [▶ page 153] added. Section <i>Quick-tester view</i> [▶ page 221] added. Device settings and options reworked Figures have been updated
8	2018-05-15	2.9	Section <i>Quicktester settings</i> [▶ page 46] added. Section <i>PDF report</i> [▶ page 251] added.
9	2019-03-29	2.10	Chapter <i>Analyzing EtherNet/IP frames</i> [▶ page 83] added. Section <i>Dialogs of the Context Menu for EtherNet/IP</i> [▶ page 128] added. Section <i>Dialogs of the context menu for PROFINET</i> [▶ page 110] reworked.

Table 1: List of revisions

1.1.2 Conventions in this manual

Notes, instructions and results of operating steps are marked as follows:

Notes



Important:

<important note you must follow to avoid malfunction>



Note:

<general note>



<note where to find further information>

Instructions

1. Operation purpose
2. Operation purpose
 - Instruction

Results

- ↻ Intermediate result
- ⇒ Final result

1.2 Contents of the product DVD

You can download the netANALYZER Scope DVD as a ZIP file from <https://www.hilscher.com> (**Support > Downloads**) to your local hard drive and unzip it. The DVD contains all the necessary drivers, software components and the documentation for the NANL-C500-RE analyzer card and the NANLB500G-RE analyzer:

- Setup for netANALYZER Scope, netANALYZER / netSCOPE Device Driver (32 bit and 64 bit) netANALYZER Software, License Manager, Ethernet Device Configuration Tool, WinPcap driver, etc.
- Firmware update file for analyzer device NANL-B500G-RE
- Documentation and and video podcast featuring commissioning example
- Example projects for netANALYZER Scope and examples for the netANALYZER Application Programming Interface (API)

1.2.1 Directory structure of the DVD

Directory name	Description
Root directory	Autostart menu: netANALYZER-Scope-2.exe
Documentation	Documentation in Acrobat® Reader Format (PDF), Adobe Flash Player installation program, videos.
Examples	Application examples for netANALYZER Scope and two programming examples for the programming interface (API) for the analyzer card NANL-C500-RE and the analyzer device NANL-B500G-RE.
fscommand	Files supporting the installation program
NANL-B500G-RE firmware update	Firmware update for NANL-B500G-RE
Setup	Installer which installs the individual components

Table 2: Directory structure of the netANALYZER Scope DVD

1.3 Legal notes

Copyright

© Hilscher Gesellschaft für Systemautomation mbH

All rights reserved.

The images, photographs and texts in the accompanying materials (in the form of a user's manual, operator's manual, Statement of Work document and all other document types, support texts, documentation, etc.) are protected by German and international copyright and by international trade and protective provisions. Without the prior written consent, you do not have permission to duplicate them either in full or in part using technical or mechanical methods (print, photocopy or any other method), to edit them using electronic systems or to transfer them. You are not permitted to make changes to copyright notices, markings, trademarks or ownership declarations. Illustrations are provided without taking the patent situation into account. Any company names and product designations provided in this document may be brands or trademarks by the corresponding owner and may be protected under trademark, brand or patent law. Any form of further use shall require the express consent from the relevant owner of the rights.

Important notes

Utmost care was/is given in the preparation of the documentation at hand consisting of a user's manual, operating manual and any other document type and accompanying texts. However, errors cannot be ruled out. Therefore, we cannot assume any guarantee or legal responsibility for erroneous information or liability of any kind. You are hereby made aware that descriptions found in the user's manual, the accompanying texts and the documentation neither represent a guarantee nor any indication on proper use as stipulated in the agreement or a promised attribute. It cannot be ruled out that the user's manual, the accompanying texts and the documentation do not completely match the described attributes, standards or any other data for the delivered product. A warranty or guarantee with respect to the correctness or accuracy of the information is not assumed.

We reserve the right to modify our products and the specifications for such as well as the corresponding documentation in the form of a user's manual, operating manual and/or any other document types and accompanying texts at any time and without notice without being required to notify of said modification. Changes shall be taken into account in future manuals and do not represent an obligation of any kind, in particular there shall be no right to have delivered documents revised. The manual delivered with the product shall apply.

Under no circumstances shall Hilscher Gesellschaft für Systemautomation mbH be liable for direct, indirect, ancillary or subsequent damage, or for any loss of income, which may arise after use of the information contained herein.

Liability disclaimer

The hardware and/or software was created and tested by Hilscher Gesellschaft für Systemautomation mbH with utmost care and is made available as is. No warranty can be assumed for the performance or flawlessness of the hardware and/or software under all application conditions and scenarios and the work results achieved by the user when using the hardware and/or software. Liability for any damage that may have occurred as a result of using the hardware and/or software or the corresponding documents shall be limited to an event involving willful intent or a grossly negligent violation of a fundamental contractual obligation. However, the right to assert damages due to a violation of a fundamental contractual obligation shall be limited to contract-typical foreseeable damage.

It is hereby expressly agreed upon in particular that any use or utilization of the hardware and/or software in connection with

- Flight control systems in aviation and aerospace;
- Nuclear fusion processes in nuclear power plants;
- Medical devices used for life support and
- Vehicle control systems used in passenger transport

shall be excluded. Use of the hardware and/or software in any of the following areas is strictly prohibited:

- For military purposes or in weaponry;
- For designing, engineering, maintaining or operating nuclear systems;
- In flight safety systems, aviation and flight telecommunications systems;
- In life-support systems;
- In systems in which any malfunction in the hardware and/or software may result in physical injuries or fatalities.

You are hereby made aware that the hardware and/or software was not created for use in hazardous environments, which require fail-safe control mechanisms. Use of the hardware and/or software in this kind of environment shall be at your own risk; any liability for damage or loss due to impermissible use shall be excluded.

Warranty

Hilscher Gesellschaft für Systemautomation mbH hereby guarantees that the software shall run without errors in accordance with the requirements listed in the specifications and that there were no defects on the date of acceptance. The warranty period shall be 12 months commencing as of the date of acceptance or purchase (with express declaration or implied, by customer's conclusive behavior, e.g. putting into operation permanently).

The warranty obligation for equipment (hardware) we produce is 36 months, calculated as of the date of delivery ex works. The aforementioned provisions shall not apply if longer warranty periods are mandatory by law pursuant to Section 438 (1.2) BGB, Section 479 (1) BGB and Section 634a (1) BGB [Bürgerliches Gesetzbuch; German Civil Code] If, despite of all due care taken, the delivered product should have a defect, which already

existed at the time of the transfer of risk, it shall be at our discretion to either repair the product or to deliver a replacement product, subject to timely notification of defect.

The warranty obligation shall not apply if the notification of defect is not asserted promptly, if the purchaser or third party has tampered with the products, if the defect is the result of natural wear, was caused by unfavorable operating conditions or is due to violations against our operating regulations or against rules of good electrical engineering practice, or if our request to return the defective object is not promptly complied with.

Costs of support, maintenance, customization and product care

Please be advised that any subsequent improvement shall only be free of charge if a defect is found. Any form of technical support, maintenance and customization is not a warranty service, but instead shall be charged extra.

Additional guarantees

Although the hardware and software was developed and tested in-depth with greatest care, Hilscher Gesellschaft für Systemautomation mbH shall not assume any guarantee for the suitability thereof for any purpose that was not confirmed in writing. No guarantee can be granted whereby the hardware and software satisfies your requirements, or the use of the hardware and/or software is uninterrupted or the hardware and/or software is fault-free.

It cannot be guaranteed that patents and/or ownership privileges have not been infringed upon or violated or that the products are free from third-party influence. No additional guarantees or promises shall be made as to whether the product is market current, free from deficiency in title, or can be integrated or is usable for specific purposes, unless such guarantees or promises are required under existing law and cannot be restricted.

Confidentiality

The customer hereby expressly acknowledges that this document contains trade secrets, information protected by copyright and other patent and ownership privileges as well as any related rights of Hilscher Gesellschaft für Systemautomation mbH. The customer agrees to treat as confidential all of the information made available to customer by Hilscher Gesellschaft für Systemautomation mbH and rights, which were disclosed by Hilscher Gesellschaft für Systemautomation mbH and that were made accessible as well as the terms and conditions of this agreement itself.

The parties hereby agree to one another that the information that each party receives from the other party respectively is and shall remain the intellectual property of said other party, unless provided for otherwise in a contractual agreement.

The customer must not allow any third party to become knowledgeable of this expertise and shall only provide knowledge thereof to authorized users as appropriate and necessary. Companies associated with the customer shall not be deemed third parties. The customer must obligate authorized

users to confidentiality. The customer should only use the confidential information in connection with the performances specified in this agreement.

The customer must not use this confidential information to his own advantage or for his own purposes or rather to the advantage or for the purpose of a third party, nor must it be used for commercial purposes and this confidential information must only be used to the extent provided for in this agreement or otherwise to the extent as expressly authorized by the disclosing party in written form. The customer has the right, subject to the obligation to confidentiality, to disclose the terms and conditions of this agreement directly to his legal and financial consultants as would be required for the customer's normal business operation.

Export provisions

The delivered product (including technical data) is subject to the legal export and/or import laws as well as any associated regulations of various countries, especially such laws applicable in Germany and in the United States. The products / hardware / software must not be exported into such countries for which export is prohibited under US American export control laws and its supplementary provisions. You hereby agree to strictly follow the regulations and to yourself be responsible for observing them. You are hereby made aware that you may be required to obtain governmental approval to export, reexport or import the product.

Terms and conditions

Please read the notes about additional legal aspects on our netIOT web site under <http://www.netiot.com/netiot/netiot-edge/terms-and-conditions/>.

1.4 Registered trademarks

Windows® 7, Windows® 8 and Windows® 10 are registered trademarks of the Microsoft Corporation.

Studio 5000 is a registered trademark of Rockwell Automation, Inc., Milwaukee, Wisconsin, USA.

Wireshark® and the "fin" logo are registered trademarks of Gerald Combs.

Adobe-Acrobat® is a registered trademark of the Adobe Systems Incorporated.

All other brands mentioned are property of their relevant rights holder. Any company names and product designations provided in this document may be brands (company names or trademarks) of the corresponding owner and may be protected under trademark or patent law.

2 Fundamentals

The netANALYZER series consists of the following devices:

- the netANALYZER PC card **NANL-C500-RE** with PCI interface for Real-time Ethernet and all 10/10BASE-T Ethernet networks
- the portable analyzer device **NANL-B500G-RE** with Gigabit Ethernet PC interface NANL-B500G-RE for Real-time Ethernet and all 10/10BASE-T Ethernet networks

If in the following the denomination "netANALYZER device" is used, this relates to all devices mentioned here.

2.1 Addressed users and usage

netANALYZER Scope is a software tool for all netANALYZER devices targeted for

- Device manufacturers
- Plant and system engineers
- Plant and system operators

who intend to analyze their Real-Time Ethernet systems on transmission, application and process level for instance in order to examine malfunction during development, commissioning and steady operation early and precisely or in order to reveal latent optimization potential in their plants and systems. For instance, this is useful in troubleshooting in order to analyze errors in bus communication.

Therefore a need exists for modern tools enabling efficient analysis on a higher level than the pure Ethernet frame level and also taking care of process-specific aspects of the respective Real-Time Ethernet system. Consequently, Hilscher has developed netANALYZER Scope as a particularly suitable analysis tool. This allows relevant information to be identified and evaluated quickly even in large amounts of data.

netANALYZER Scope also supports a lot of serviceable functions on the pure Ethernet frame level.

2.2 Recording and analyzing data traffic

You can use the netANALYZER cards and portable devices to record the timing, the network load and the functions of individual systems or system components bus systems, which conform to the IEEE802.3, the EtherCAT specification (reference [2]) or the PROFINET specification (reference [3]).

The netANALYZER devices analyze the data traffic in a communication stretch and protocols the arriving frames.

This is schematically illustrated in the figure below:

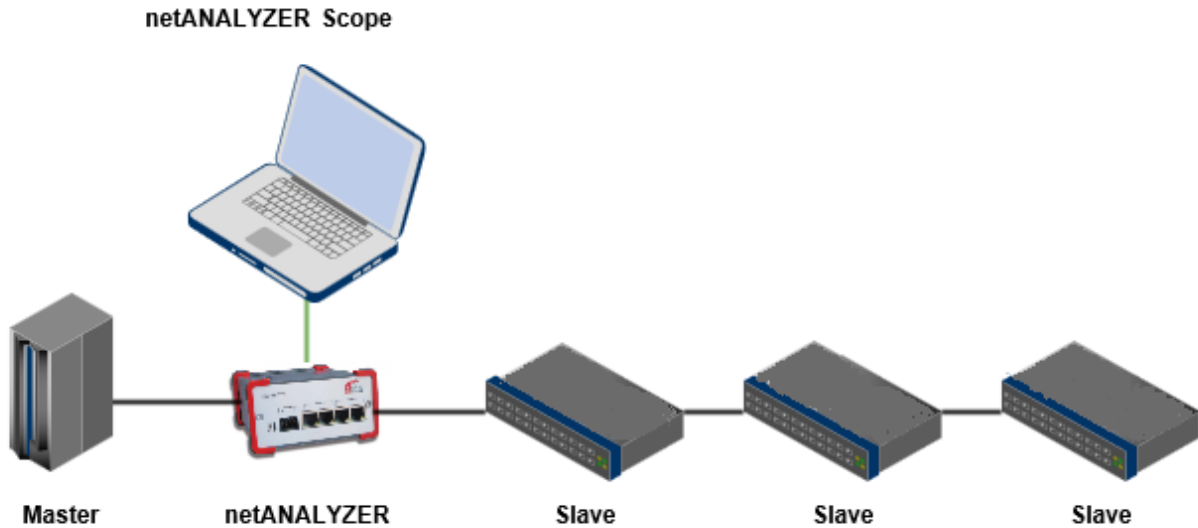

Figure 1: Recording Scenario with netANALYZER Scope between Master and Slaves

Cabling can be done as follows:

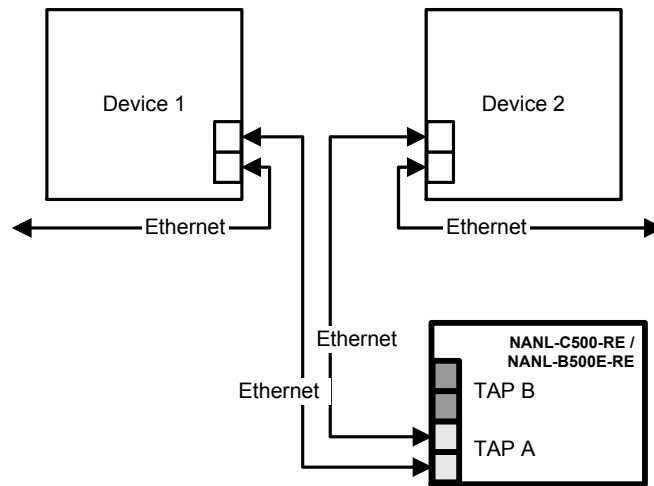

Figure 2: Typical Application - The communication between a device and its connection partners in a network should be analyzed

For devices with two Ethernet channels the analyzer card NANL-C500-RE and the analyzer device NANL-B500G-RE capture the Ethernet frames and adds the time stamps to them. Therefore the netANALYZER device must be connected from any TAP to the Ethernet device connections via two patch cables.

The following figure illustrates an example of the physical TAP.

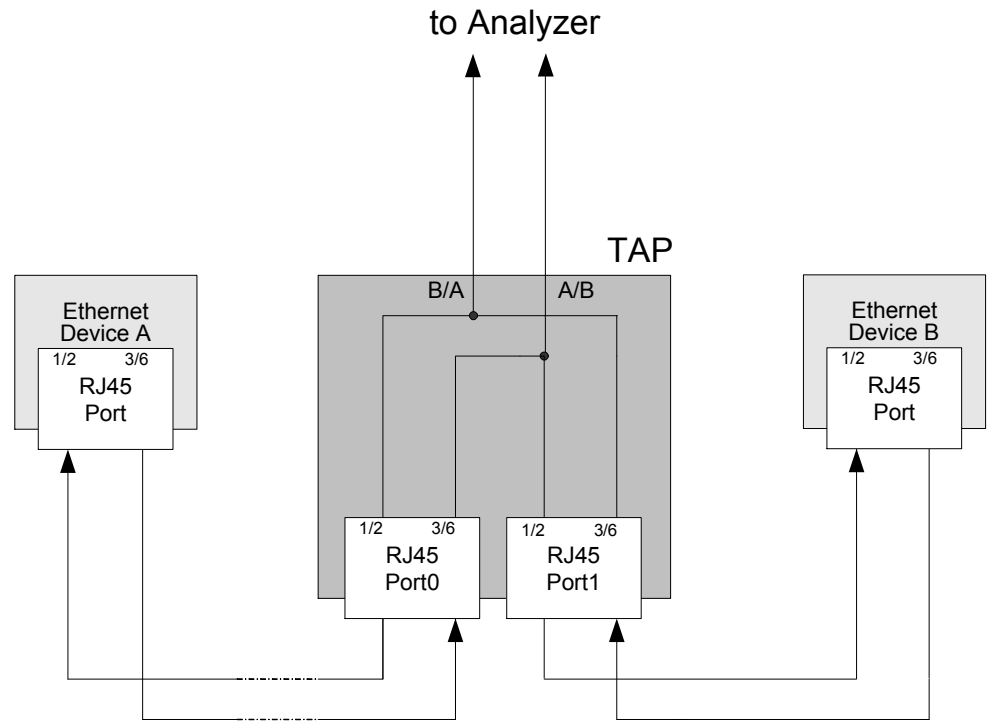

Figure 3: Example representation physical TAP

2.3 Functional overview

netANALYZER Scope offers the following main functions:

- Process data acquisition directly on the network
 - No intrusion into the PLC or slave software necessary
- Process data acquisition operates with cycle accuracy
- Clear and concise presentation of recordings
 - Display of all available devices is structured within a tree view
 - The graphical visualization of process values is implemented as line writer (“Scope”).
- Remote debugging
 - Storing and reloading of all recorded data is supported.
 - Easy viewing of process values on a remote PC at any time
- Freely configurable triggers
 - These help especially when searching for sporadic errors.
 - Triggering on *Communication events* [▶ page 81]possible.
- Cursor, marker and search function
 - These enable easy and quick finding and measuring of values
- Interface to Wireshark®
 - Allows very precise additional analysis of standard Ethernet data

Protocol-specific functions

- Standard-Ethernet
 - Timing analysis (jitter and delay measurements)
 - Netload analysis
 - Numerous filter criteria available, see section *Editing filter conditions* [▶ page 162].
 - Custom value filters for the graphic representation of series of values of arbitrary data extracted from Ethernet frames
- All Real Time-Ethernet systems
 - Frames (SERCOS, EtherNet/IP etc.) can be detected via custom value filters.
- EtherCAT
 - Additionally: The import of signal names is accomplished by examining the EtherCAT Network Information file (*.ENI file)
- PROFINET
 - Additionally: The import of signal names is accomplished by examining the GSDML file. For automatic recognition it is recommended to examine the whole startup phase of the PROFINET network.
 - Additionally: Event recognition
- EtherNet/IP
 - Additionally: The import of signal names is accomplished by examining the Rockwell Studio 5000 project and the EDS files.

2.4 Licensing

2.4.1 Licensing for single functionalities

The following functionalities of netANALYZER Scope are generally enabled without an additional license:

netANALYZER Scope functions (usable without license)

You can use the following functions of netANALYZER Scope without any licence::

1. Frame recording
2. Netload analysis
3. Timing analysis
4. PCAP export

In these functions, the recording time is limited only by the available memory.

Basic license

A license consists of the netANALYZER Scope base license (8582.001 LIC/SCPBS), this license enables the trigger function and allows using single additional licenses (1.-5.). when acquiring the base license, At the same time at least one additional license is required,

Further licenses can be acquired via the license manager, see below.

netANALYZER Scope functions (only usable with appropriate license)

The following functions of netANALYZER Scope require a license:

Function	Licence
Process data acquisition and analysis (EtherCAT)	License 8582.040 LIC/SCP/ECAT
Process data acquisition and analysis (PROFINET), including PROFINET event detection:	License 8582.030 LIC/SCP/PN
Quick tester (PROFINET)	License 8582.031 LIC/SCP/QTPN
Process data acquisition and analysis (EtherNet/ IP)	Lizenz 8582.080 LIC/SCP/EIP
Custom value filters	License 8582.050 LIC/SCP/CVF
PCAP import	License 8582.070 LIC/SCP/PCAP
Autonomous operation	License 8582.060 LIC/NANL/SA
Trigger functions	Contained in base license, see below.

Storage of licenses

The licenses acquired by you are stored within the netANALYZER device, not in the PC where netANALYZER Scope is running on. So if you move to another PC, your licenses will still remain. In order to detect the licenses correctly, a connection between the PC running netANALYZER Scope and the netANALYZER device must be established.

2.4.2 License Manager

The License Manager is a special software for the acquisition, download and administration of licenses for Hilscher products.



For a detailed description of the Hilscher License Manager, refer to User manual, netANALYZER Scope licensing, overview, V2.0 (Document ID: DOC150205UM02EN) and Operating instruction manual, Hilscher License Manager, Description of software licensing, V1.0200 (Document ID: DOC131201OI03EN).

2.4.3 License model

In the following cases, no license is necessary:

In order to display recordings made with netANALYZER Scope on other computers, the usage of netANALYZER Scope on other computers with no installed netANALYZER hardware is allowed without an additional license for customers having already a license for netANALYZER Scope.

There is an evaluation version of netANALYZER Scope available from Hilscher free of charge. This special version differs from the full version only in its limited recording time.

2.5 Timestamps

Timestamps are always used at the end of SFD (Start Frame Delimiter) of the respective Ethernet frame, also see reference [1].

Variables can extend over multiple Ethernet frames. In this case the figure below shows how timestamping is accomplished when variables extend over multiple frames.

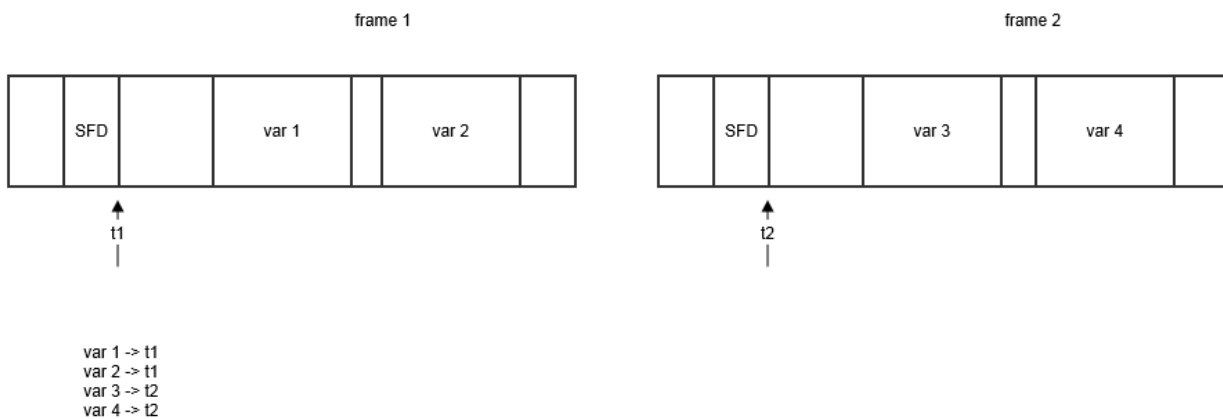

Figure 4: Time stamping when variables extend over multiple Ethernet frames

For each variable, the timestamp of that frame is taken, in which the variable resides, for instance for the variables of the figure var1 and var2 will be timestamped with the value t1, var3 and var4 with the value t2.

The maximum achievable timestamp accuracy amounts 10 ns.

2.6 Installing the netANALYZER Scope software

The installation of the netANALYZER Scope software is described in a separate document due to its size and the multitude of components (drivers, for instance) which are installed together with netANALYZER Scope: Hilscher Gesellschaft für Systemautomation mbH: Installation guide, Software installation for netANALYZER devices, Installing driver and analyzer software, Revision 4, Document ID: DOC150201IG04EN).

Requirements for netANALYZER Scope

Operating system:

- Windows® 7 (32-bit and 64-bit version)
- Windows® 8 (32-bit and 64-bit version)
- Windows® 10 (32-bit and 64-bit version)



Note:

Windows® 10 Server is not supported.

Additional software requirements

- Microsoft .NET Framework 4.6
- Microsoft Visual C++ 2008 Redistributable Package
- Microsoft Visual C++ 2010 Redistributable Package
- Microsoft Visual C++ 2015 Redistributable Package
- Microsoft DirectX 9.0c
- netANALYZER Driver

These additionally required software components are included within the setup of netANALYZER Scope and are automatically installed, if necessary.

3 Graphical user interface

After installation, the netANALYZER Scope software still needs to be configured. In order to configure netANALYZER Scope the GUI is required, so let us first have a brief view on the GUI. The configuration itself is described in detail in the next chapter

- *Configuring netANALYZER Scope* [▶ page 33]

The GUI mainly consists of the start screen, the side menu and its submenus opening new views for instance, and the output window.

3.1 Start screen

The start screen appears in two cases:

- At start-up of the netANALYZER Scope software
- After closing a project when clicking at icon 

The start-up screen offers two actions:

- Loading an existing project (Button *Browse* in area *Load*)
- Creating a new project (Button *New* in area *Create*)

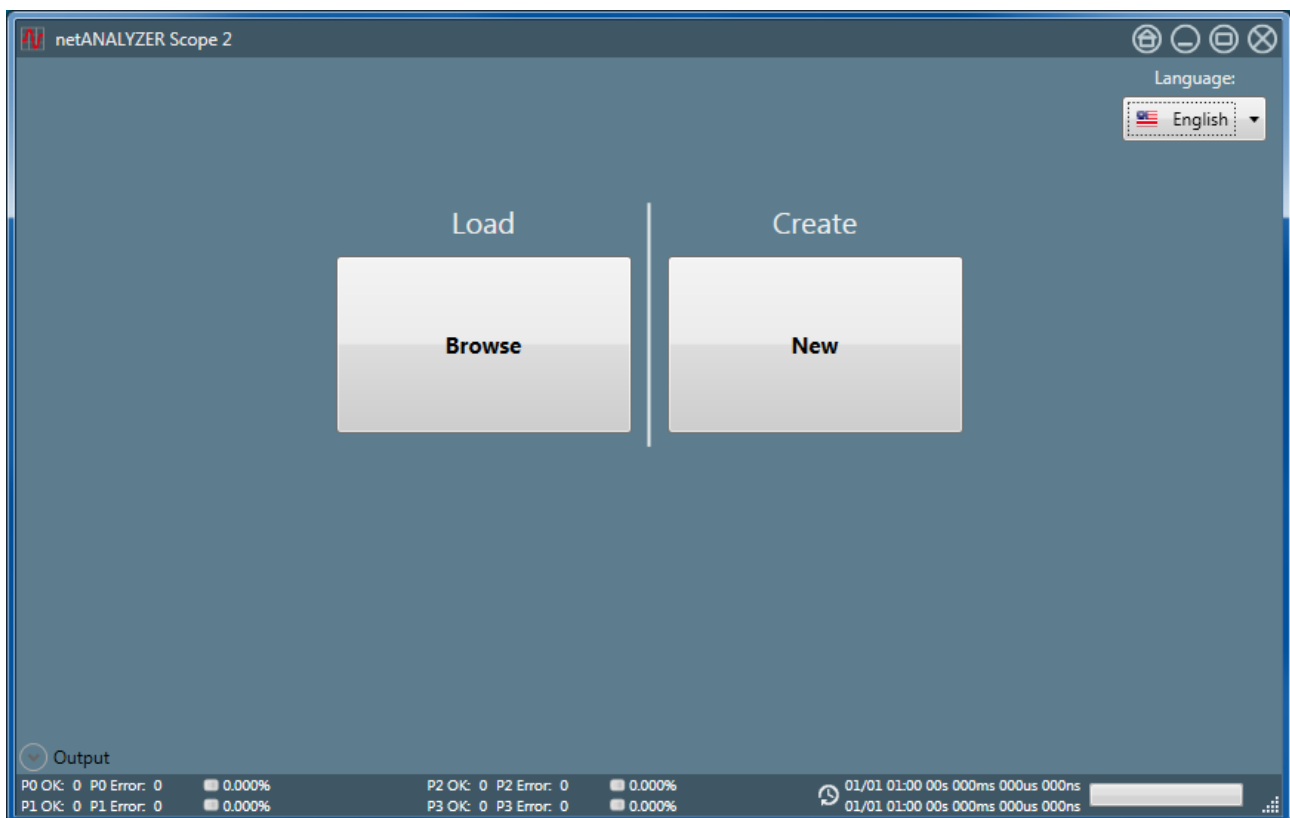

Figure 5: Start menu netANALYZER Scope

Clicking at the *Browse* button will invoke a selection dialog for a project file to be opened. Working with projects in netANALYZER Scope is described in detail in chapter *Project administration* [▶ page 61] of this manual.

Furthermore, there is a small selection list in the upper right corner of the start menu screen for adjusting the display language of netANALYZER Scope.

3.1.1 Select language



Figure 6: Language selection list

The language selector is located in the upper right corner of the start menu screen. Currently, you can select the following display languages for netANALYZER Scope there:

- English
- German

3.2 Side menu

The following figure shows the side menu for the example of an empty project. The side menu is displayed at the right edge of the window. Everytime you open a project or create one by the clicking at the **New** button, the side menu appears.

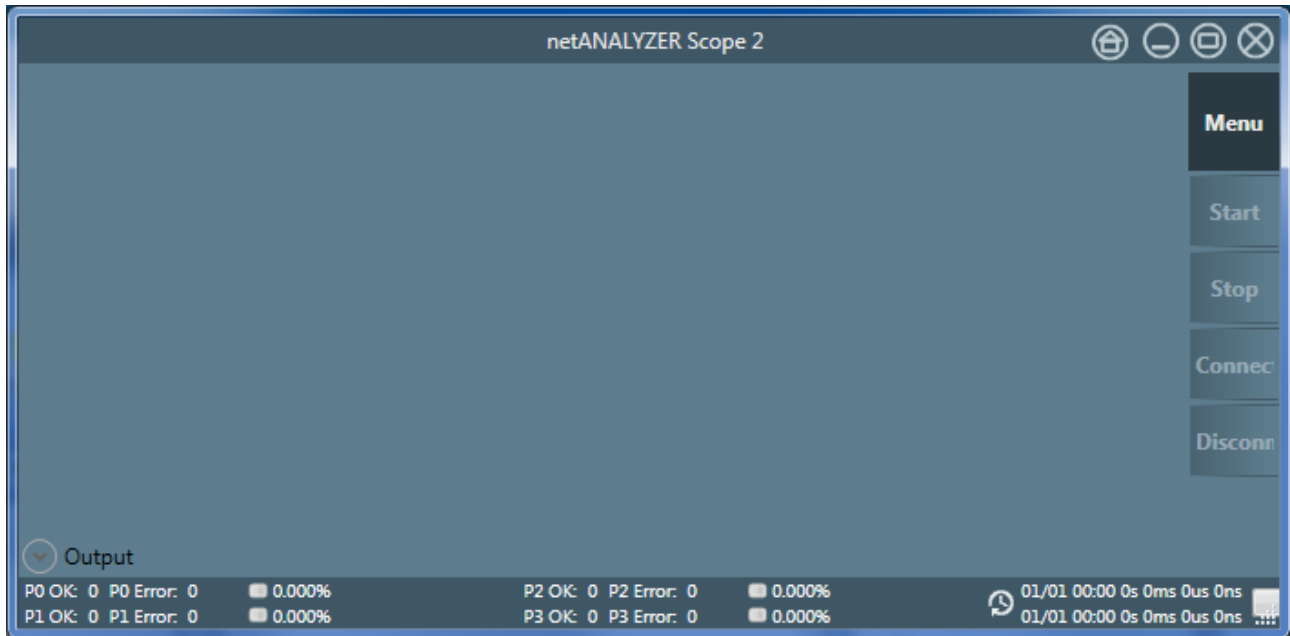

Figure 7: Side menu

The side menu has the following entries:

Menu entry	Description
Menu	Opens the main menu
Start	Starts recording data
Stop	Stops recording data
Connect	Connect (for instance for capturing the start-up of PROFINET communication)
Disconnect	Disconnect

Table 3: Menu entries of right-side menu

3.2.1 The main menu

Select **Menu** to open the main menu of netANALYZER Scope. It has 6 register cards allowing you to invoke all relevant functions of netANALYZER Scope

Register card	Description	Further information
Views	Selection of views for the representation of the recorded data	Section <i>Menu Pane Views</i> [▶ page 26]
Project	Project administration	Section <i>Menu Pane Project</i> [▶ page 27]
Tools	Tools, for instance for data export to Wireshark®	Section <i>Menu pane Tools</i> [▶ page 27]
Device Assignment	Device Assignment, Driver and device information, GPIO-/Port Configuration Configuration of Hardware Frame Filter Configuration of Capture Mode	Section <i>Menu Pane Device Assignment</i> [▶ page 28]
Options	Adjustment of important configuration parameters	Section <i>Menu Pane Options</i> [▶ page 29]
About	Information about netANALYZER Scope	Section <i>Menu Pane About</i> [▶ page 30]

Table 4: Menu Entries of Main Menu

3.2.1.1 Menu Pane Views

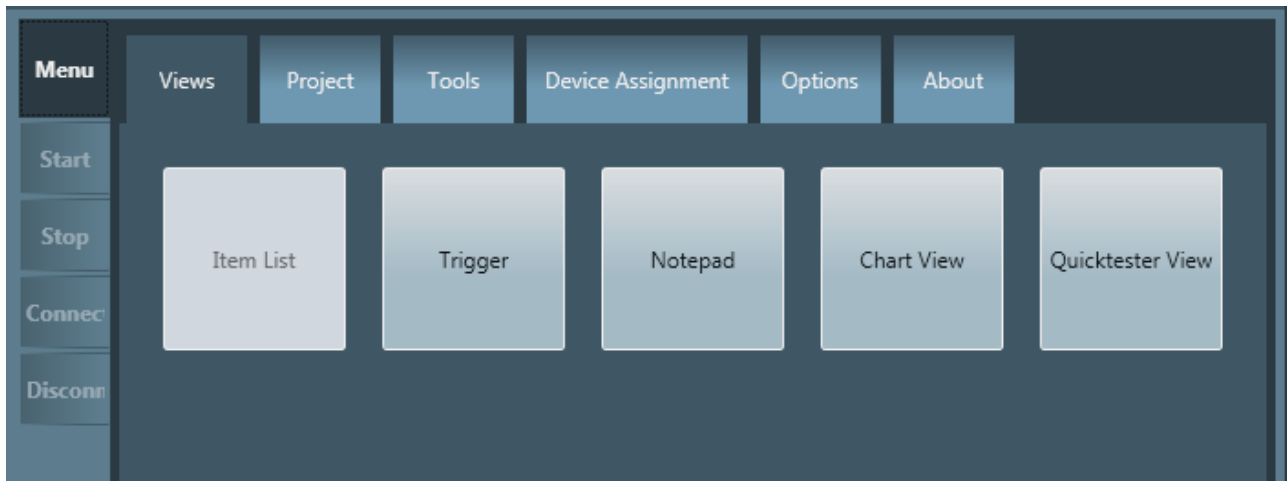

Figure 8: Menu Pane „Views“

netANALYZER Scope allows you to define three different kinds of views for the representation of the measured data and offers the possibility to open a notepad.

These can separately be selected in this menu:

Menu entry	Description	Detailed description
Item list	Lists the items (i.e. the data to be displayed) in a tabular form.	Section <i>Working with the item list view</i> [▶ page 91]
Trigger	Allows to define triggers on occurrence of an event	Section <i>Define triggers to stop recording</i> [▶ page 60]
Notebook	Opens a simple possibility to enter notes concerning your projects.	Section <i>Working with the notepad view</i> [▶ page 193]
Chart View	Displays the data as chart view.	Section <i>Display data</i> [▶ page 169]
Quicktester View	Allows fast data analysis with tools such as jitter display, conversation table and event protocol	Section <i>Quick-tester view</i> [▶ page 221]

Table 5: Menu entries register card Views

3.2.1.2 Menu Pane Project

This register card supplies all functionality necessary for the administration of projects.

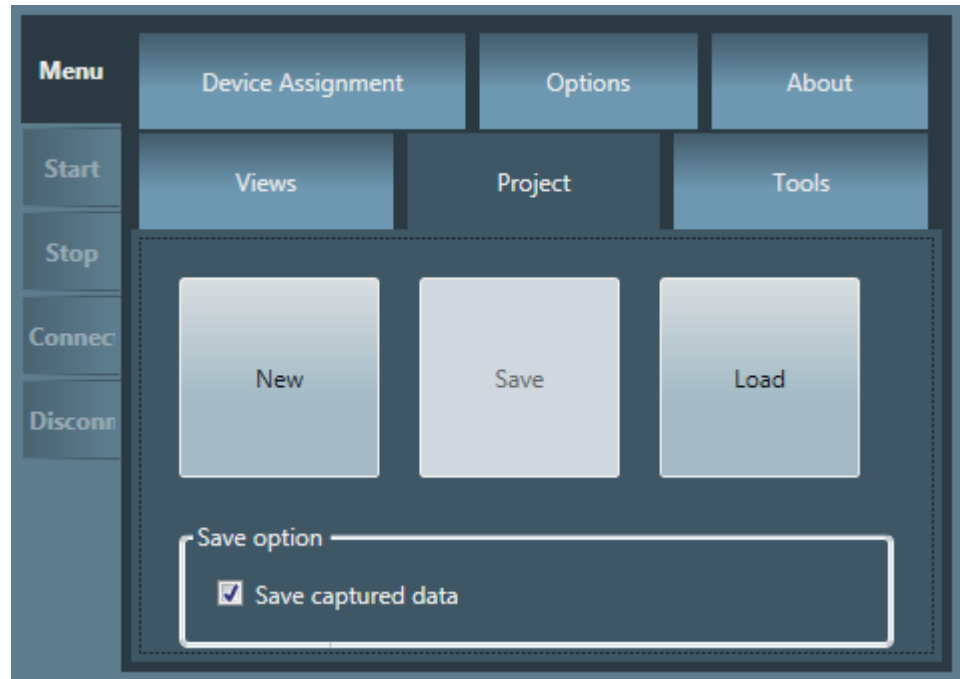

Figure 9: Menu Pane Project

For more information concerning project administration with netANALYZER Scope, see section *Project administration* [▶ page 61].

3.2.1.3 Menu pane Tools

This register card allows to start tools, currently the export of data from netANALYZER Scope to Wireshark® and for the import of data from Wireshark®.



Figure 10: Menu pane Tools

The exported data are written into a *.pcap file, which can be used as input file for further processing and analysis in Wireshark®. See *PCAP export* [▶ page 245]. Vice versa *.pcap files, for instance such of Wireshark®, can be read in using the option *PCAP Import*, if an according license is present in the device. See *PCAP import* [▶ page 247].

3.2.1.4 Menu Pane Device Assignment

This register card allows

- to assign devices,
- to configure the frame filter for Ethernet (via the *Details* button)
- to configure Ethernet- und GPIO-Ports
- and to activate or deactivate the high-load capture mode.

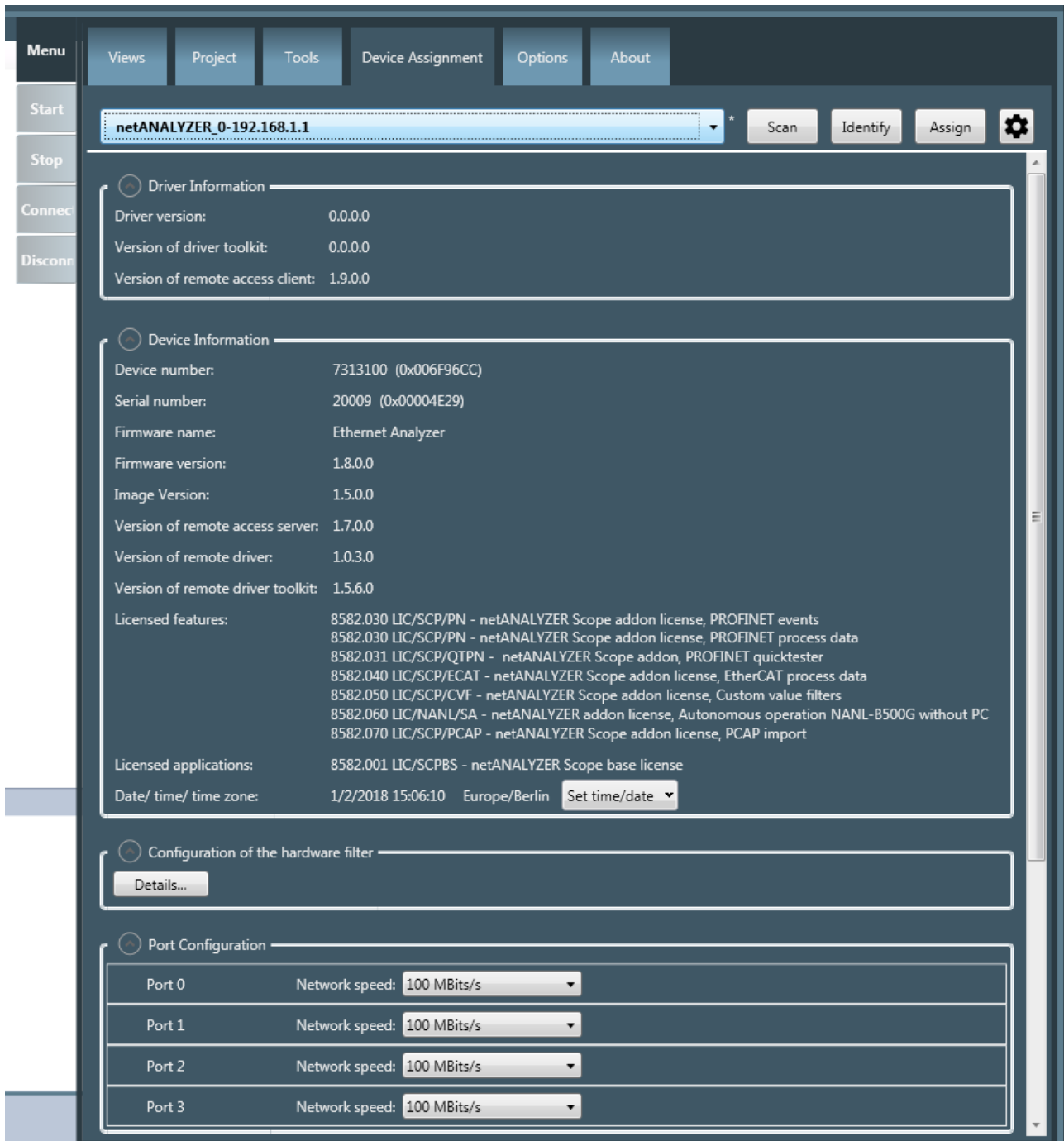

Figure 11: Menu pane "Device assignment"

3.2.1.5 Menu Pane Options

This register card allows performing the basic adjustments for recording, such as the buffer size and the storage medium and storage location.

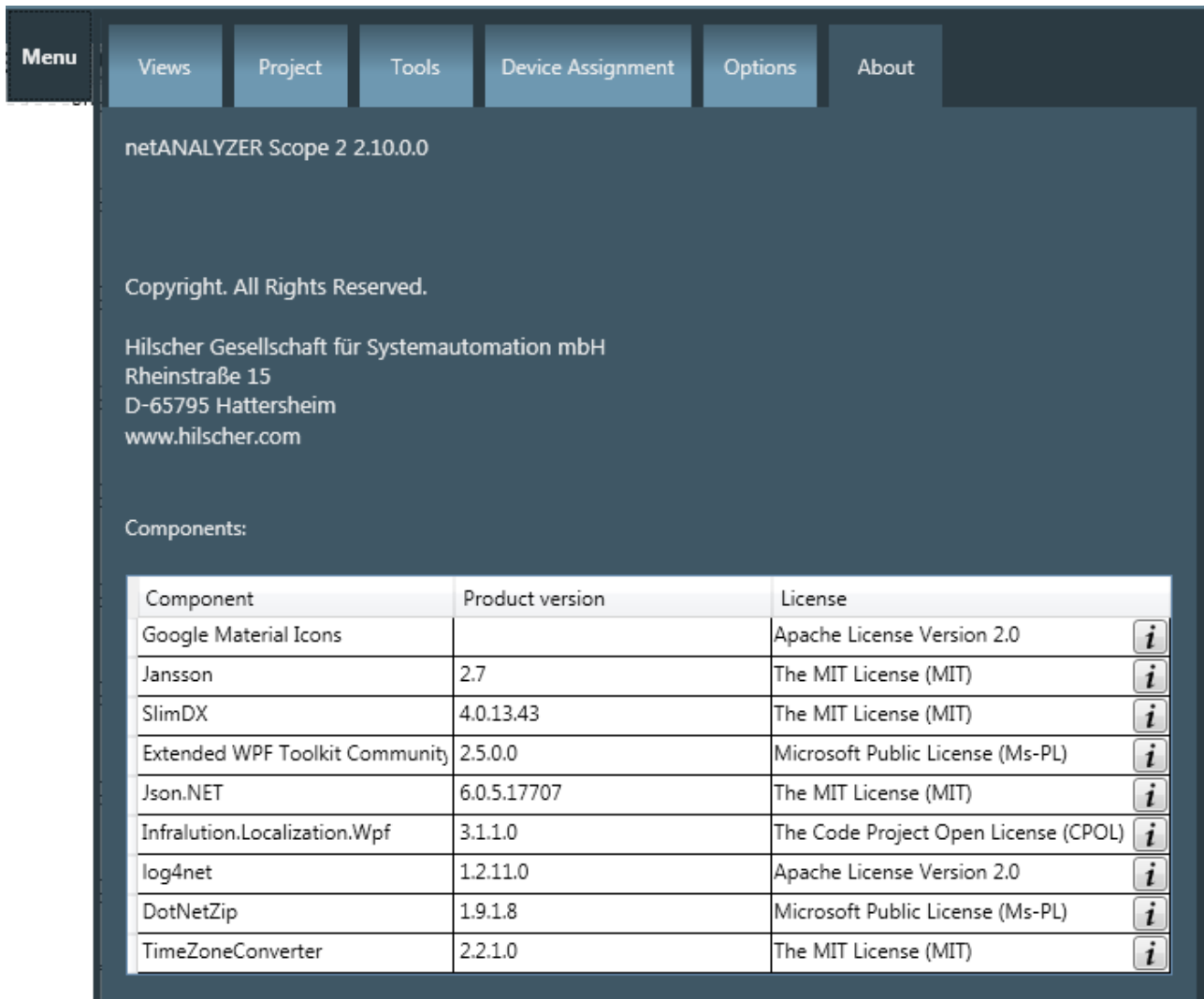

Figure 12: Menu Pane Options

3.2.1.6 Menu Pane About

This register card displays information about netANALYZER Scope itself:

- The version number of the netANALYZER Scope software
- Copyright information
- Hilscher's contact address
- Version information of the software components used in netANALYZER Scope
- Version and licence information concerning used software components



netANALYZER Scope 2 2.10.0.0

Copyright. All Rights Reserved.

Hilscher Gesellschaft für Systemautomation mbH
Rheinstraße 15
D-65795 Hattersheim
www.hilscher.com

Components:











Component	Product version	License
Google Material Icons		Apache License Version 2.0 
Jansson	2.7	The MIT License (MIT) 
SlimDX	4.0.13.43	The MIT License (MIT) 
Extended WPF Toolkit Community	2.5.0.0	Microsoft Public License (Ms-PL) 
Json.NET	6.0.5.17707	The MIT License (MIT) 
Infralution.Localization.Wpf	3.1.1.0	The Code Project Open License (CPOL) 
log4net	1.2.11.0	Apache License Version 2.0 
DotNetZip	1.9.1.8	Microsoft Public License (Ms-PL) 
TimeZoneConverter	2.2.1.0	The MIT License (MIT) 

Figure 13: Menu Pane About

For used software components, a second table at the lower edge of the menu pane displays the currently applied version numbers and the type of the applicable license. By clicking at the Info icon  on the right side within the lower table, you can display the valid license text for this component within an own windows.

3.3 Message output area

At the lower edge of the window of netANALYZER Scope, a message output area can be displayed if desired, see the following figure.

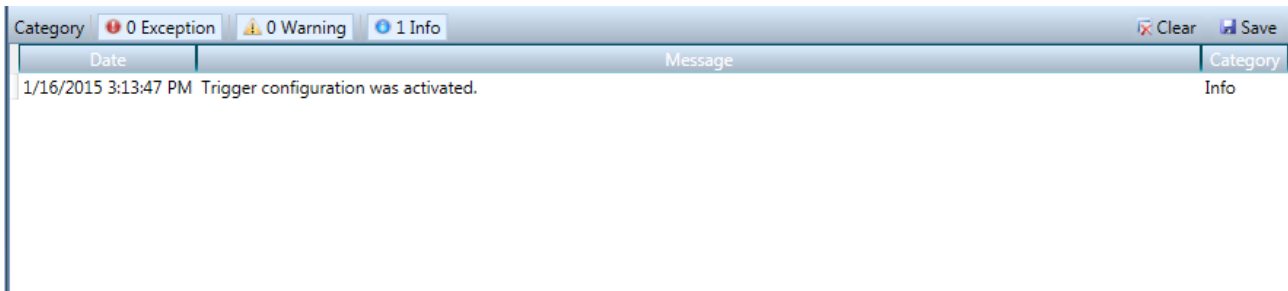

Figure 14: Message output area

Within the Message Output Area messages of various categories (levels of severity) can separately be switched on and off by clicking at the respective button within the upper row:

- Exception
- Warning
- Info
- Debug

You can delete the list of messages or store it into a file. You can also filter according to severity levels. You may choose the coding between UTF8 and Unicode.

3.4 Status bar

At the lower edge of the GUI, there is a status bar containing the frame statistics and a status indicator (on the right side) and, if there is a connection to a netANALYZER device, the telegram statistics (on the left side, only when there is a currently active connection to netANALYZER).



Figure 15: Frame statistics (without connection to netANALYZERdevice)

If there is a connection to a device, the status bar looks like this:netANALYZER



Figure 16: Telegram and frame statistics (with connection to netANALYZER device)

The last used time stamp is displayed right of center within the status bar.

At the right edge of the status line a color status indicator for the current state of operation of netANALYZER Scope is displayed.



Status indicator	Current State of netANALYZER Scope
Idle 	Idle
Gestartet 	Recording of frames has been started.
Gestoppt 	Recording of frames has been stopped.

Table 6: Color status indicator

4 Configuring netANALYZER Scope

This chapter describes how to configure the aspects of netANALYZER Scope which are independent from the chosen Real-Time Ethernet system. There are two appropriate menu entries, namely

Device Assignment

(see section *Menu Device assignment* [▶ page 34])

Menu Options

(see section *Menu „Options“* [▶ page 42])



Note:

The hardware filter settings to be configured during device assignment are described in a separate section *Filter settings for hardware filters* [▶ page 48].

The system-dependent configuration activities for netANALYZER Scope are described in the following sections *Analyzing EtherCAT frames* [▶ page 72] and *Analyzing PROFINET frames* [▶ page 78]

4.1 Menu Device assignment

The following figure displays the menu “Device assignment” if a netANALYZER device is connected to the computer and has been recognized by netANALYZER Scope.

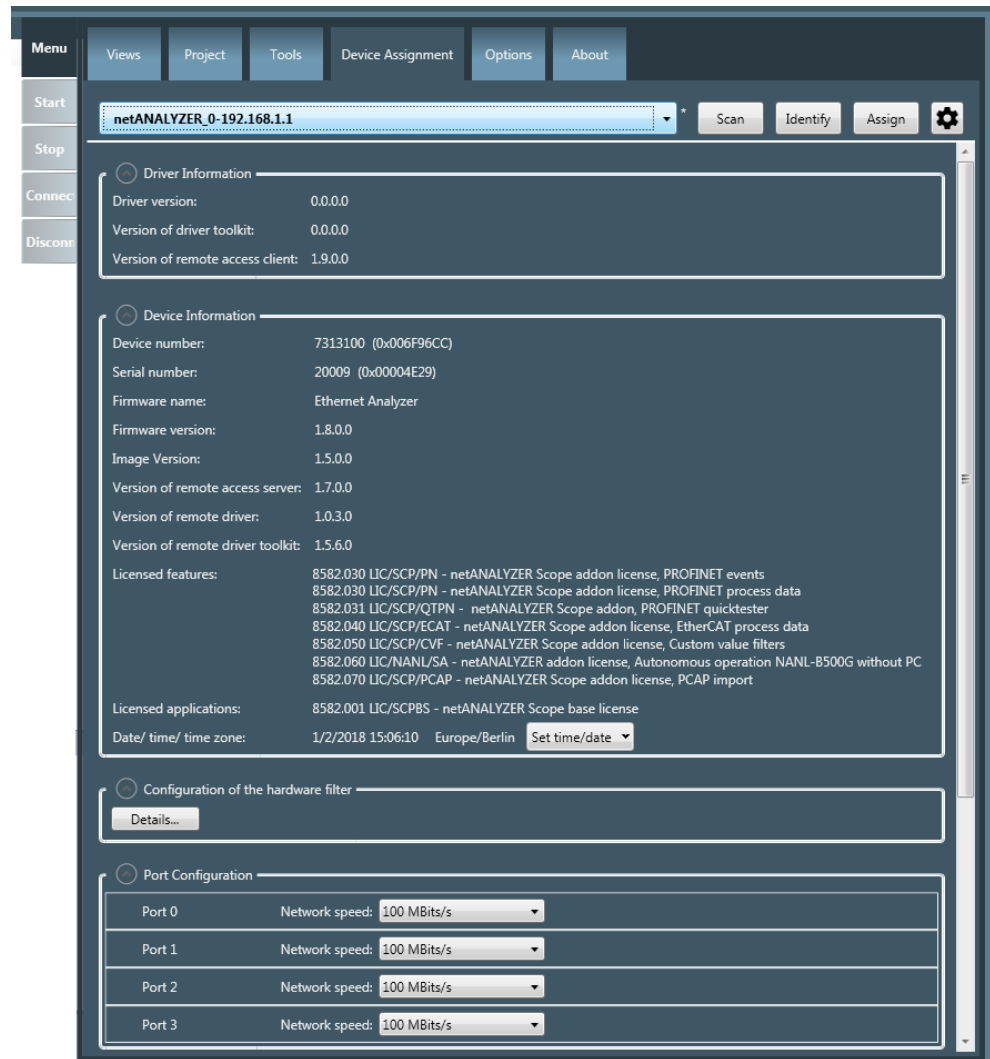

Figure 17: Menu "Device Assignment"

If a device is detected, the menu looks like this:

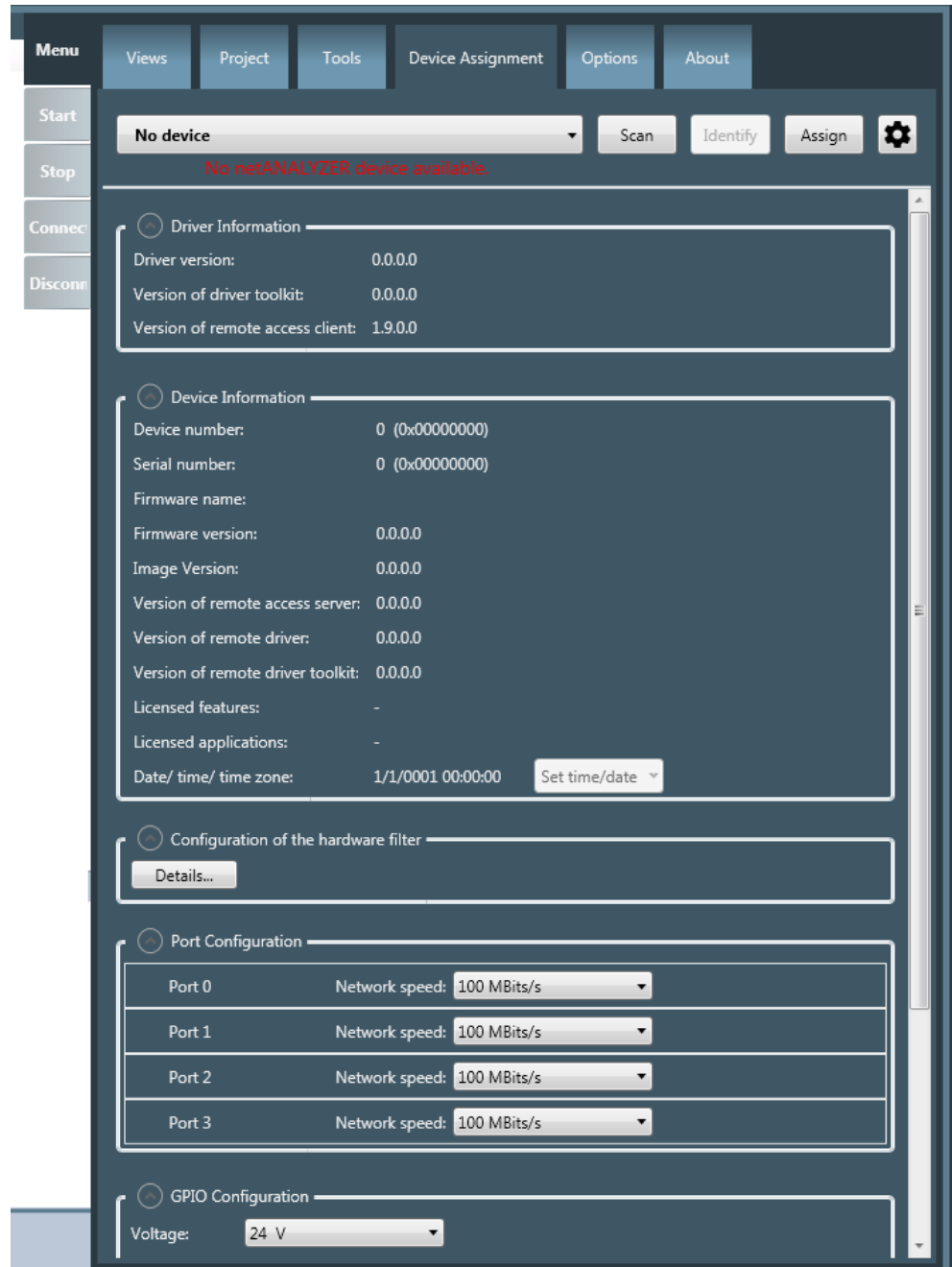

Figure 18: Menu “Device assignment” (without device)

The menu consists of the following areas:

Selection box for netANALYZER devices

If multiple netANALYZER devices have been installed at a single PC, you can select the desired netANALYZER device using the selection list in the upper left corner of this register card.

If at least one device has been found, some information concerning driver, device and ports are displayed in this register card. Here, there is always the possibility,

- to configure the applied Ethernet ports and GPIOs
- to configure hardware frame filters via the *Details*” button
- to activate or deactivate the high load recording mode.

If no netANALYZER device is installed, this is indicated by a message displayed in red color.

Driver Information



Figure 19: Driver Information area

The *Driver Information* area displays the following:

- The version number of the currently installed driver
- The version number of the driver’s toolkit
- The version number of the currently installed remote access client

Device information

The Device information area displays information about device, firmware, drivers and licensed functions.

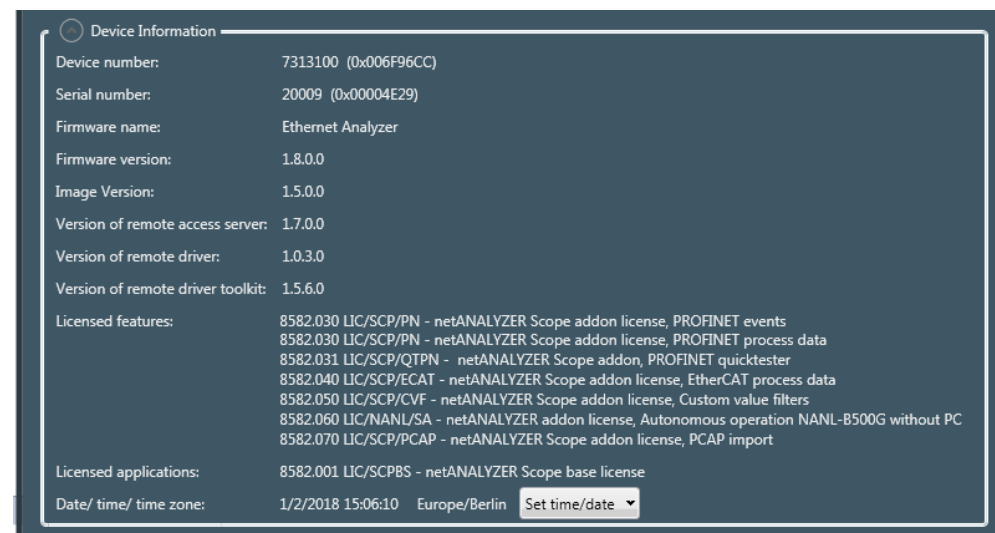

Figure 20: Device information

It also allows to set the date and time of the netANALYZER's internal clock to a new value (Button "Set time/date").

Configuration of frame filter



Figure 21: Configuration of frame filter

If this button is clicked, a new dialog opens allowing to define the ports where filtering takes place and which Ethernet frame types (and thus which protocols) will pass through the frame filter at the respective port.



Note:

You find an in-depth description of the various configuration possibilities in section *Filter settings for hardware filters* [▶ page 48].

Ports Configuration

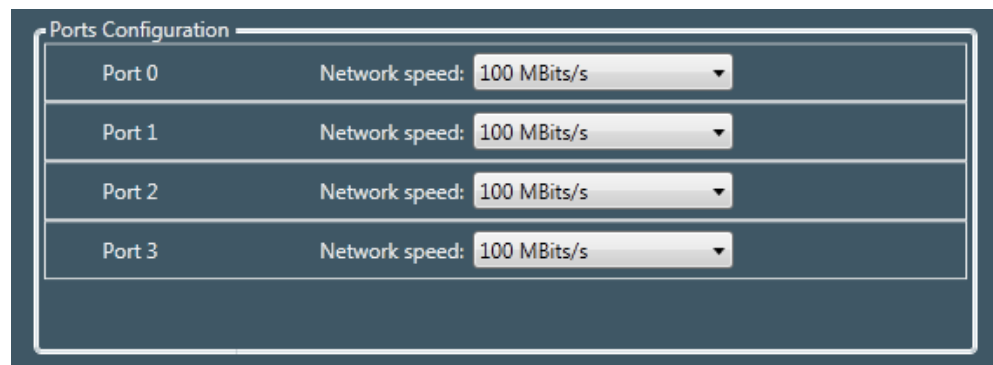

Figure 22: Ports configuration

The netANALYZER device has four ports (Port 0,1,2 and 3) which can be individually configured with regard to their network speed. Each port has its own selection list:

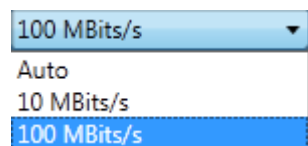

Figure 23: Network speed

It offers the following three options:

Option	Meaning
Auto	The network speed of the port is determined automatically. The network speed detection can last for up to two seconds possibly causing frames not be recorded during this time. If you want to avoid this, use a fixed network speed setting.
10 Mbits/s	The network speed of the port is set to a fixed value of 10 Mbits/s.
100 Mbits/s	The network speed of the port is set to a fixed value of 100 Mbits/s. This is the default setting.

Table 7: Options for network speed in port configuration

GPIO configuration

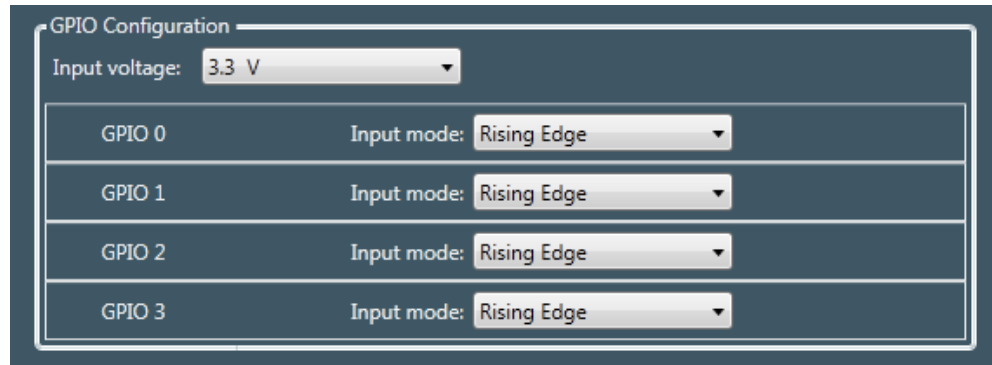

Figure 24: GPIO configuration

The netANALYZER device has four General Purpose Input Output (GPIO) lines (GPIO 0,1,2 and 3) which can individually be configured with regard to their input mode. Each line has its own selection list *GPIO Mode*:

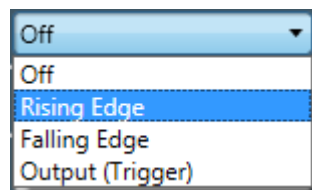

Figure 25: Input Mode

This list offers the following four options:

Option	Meaning
Off	The input/ output line is switched off.
Rising edge	Triggering takes place at rising edge of the signal.
Falling edge	Triggering takes place at falling edge of the signal.
Output (Trigger)	The GPIO can be used as triggering output in order to put out a signal level if a trigger condition occurs. In this case, right beside the selection list a further selection list is displayed offering the options High active and Low active for the output.

Table 8: GPIO configuration

The voltage of the signal is configured collectively for all four GPIOs together. This is done using the selection list *Voltage* offering the following choices:

- 24 V
- 3.3 V

Capture mode



Figure 26: Checkbox Enable high load capture mode

Switching on the high load capture mode is accomplished by checking *Enable high load capture mode*.

When should I switch on the high load capture mode?

The high load capture mode can be used to reduce the load of the data to be copied from the netANALYZER to the PC. All frames exceeding a length of 58 are truncated in order to omit a large amount of the data part.



Note:

Some functions of the netANALYZER hardware such as the process data display may only be usable with restrictions when activating the high load capture mode.

If both of the following conditions simultaneously apply, it may be useful to switch on the high load capture mode:

- The expected maximum network load exceeds 96%.
- Four Ethernet ports are used.

You can do this by checking the *Enable high load capture mode* checkbox.

4.1.1 Assigning a device

Selection list for devices

If more than one netANALYZER device (cards and portable devices together) is connected to your computer, you can select which one to use here. If no device has been detected on your computer, this list will remain empty, and a message will indicate that no netANALYZER device is available.

Buttons Scan, Identify and Assign

The buttons at the right upper edge of menu “Device assignment” have the following meaning:





Button		Meaning
	Scan	Using the Scan button, you can scan for all available netANALYZER devices available for use in netANALYZER Scope. All found netANALYZER devices will be listed in the selection list for device assignment as soon as the scan has been finished. The scan may last for a few seconds.
	Identify	The Identify button allows you to identify a selected netANALYZER hardware. This may especially be useful in case multiple netANALYZER devices have been installed. Select the netANALYZER device of your interest in the selection list for device assignment. Then click at the Identify button. Finally, the Status LEDs STA0 and STA1 of the selected netANALYZER device will be blinking in green color for some seconds.
	Assign	Using the Assign button you can select the current device and use its current configuration. Starting with netANALYZER Scope version 2.5, Assignment can even be done if the device is not (yet) installed.
	Settings	With the Settings button, you can open the dialog Device scan settings for static IP configuration. There you can administer the list of devices to be included during a device scan.

Table 9: Buttons of device assignment

You can also administer the IP list with the dialog **Static IP configuration**.

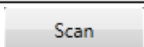
Invoking the static IP configuration

To invoke the static IP configuration, proceed as follows:

- Click at 
- ⇒ The dialog of the static IP configuration appears.

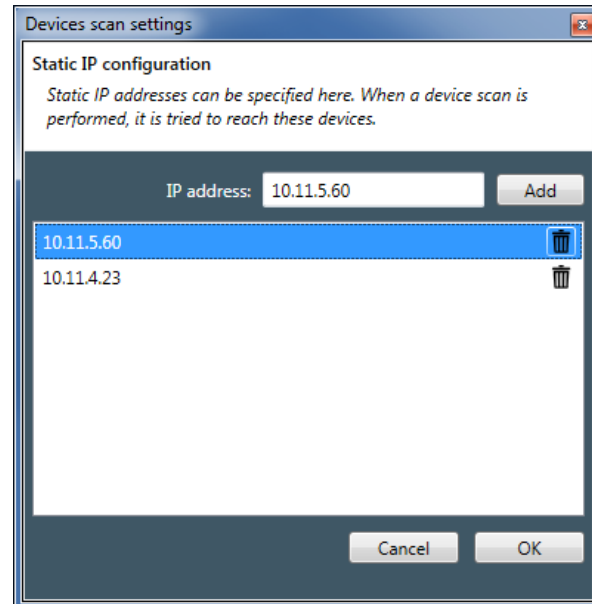

Figure 27: Static IP configuration

Adding an IP address

In order to add an IP address to the list of the static IP configuration, proceed as follows:

- Click at **Add**.
- ⇒ The IP address gets a member of the list of static IP configuration.

Deleting an IP address

To remove an IP address from the list of the static IP configuration, proceed as follows:

- Click at the waste basket symbol  right of the IP address to be removed from the list.
- ⇒ Immediately, the IP address is removed from the list of IP address of the static IP configuration.

4.2 Menu „Options“

The options menu provides configuration options for:

- Selection of autonomous or manual operation
- Adjusting the size of the recording buffer
- Selection of recording medium (HDD or RAM)
- Setting the overload behavior
- Settings for the quicktester

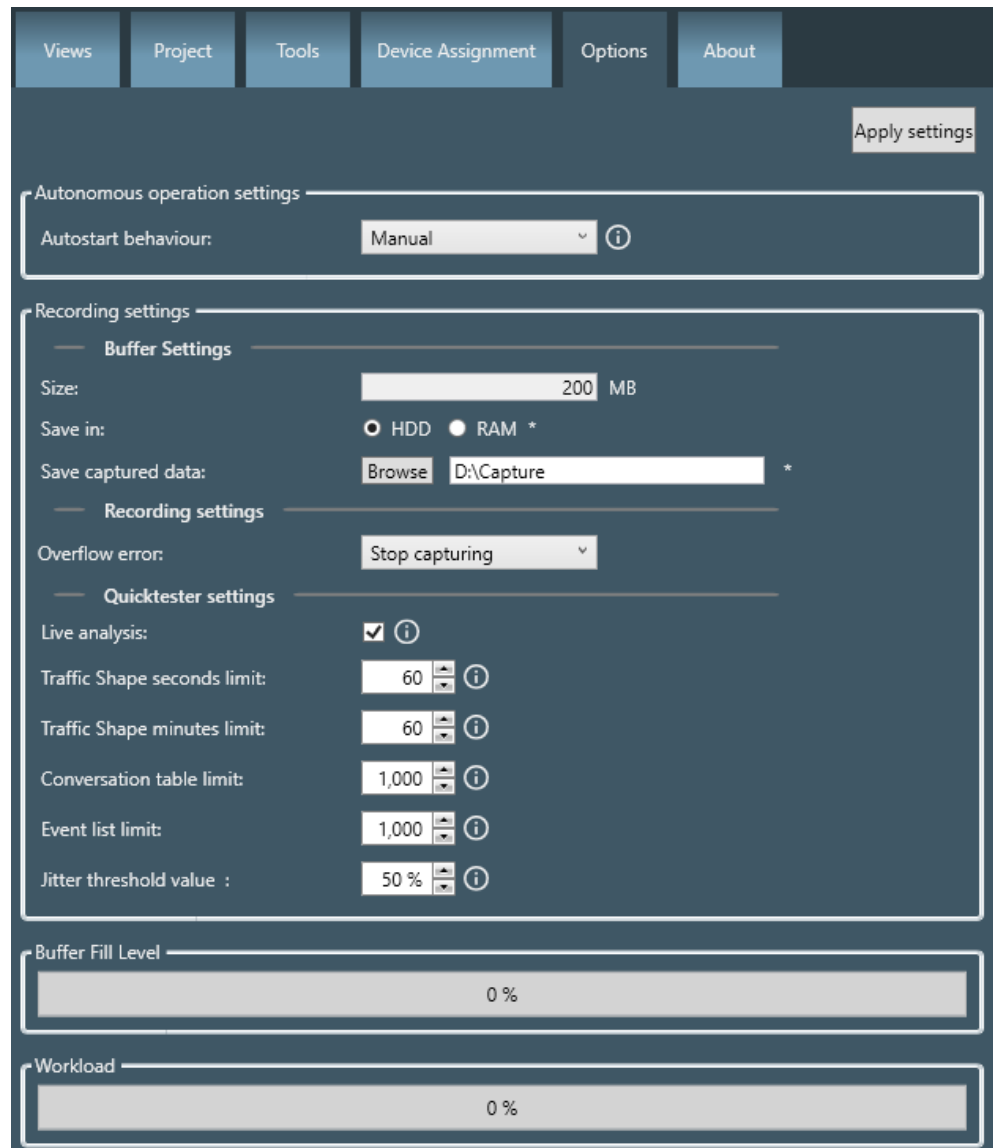

Figure 28: Menu „Options“

4.2.1 Settings for autonomous operation

Here the behavior of the netANALYZER for autonomous operation can be adjusted. The selection list *Autostart behavior* provides the following options for autonomous or manual operation:

Settings	Meaning
Manual	The data acquisition of the netANALYZER can only be started manually (via the REC pushbutton of the netANALYZER).
Autostart	The data acquisition starts automatically after startup of the device and connecting a USB medium with *.nsprj file. This requires a license for autonomous operation (Order no. 8582.060 LIC/NANL/SA).

Table 10: Settings for autonomous operation

**Note:**

If a USB mass storage device with a partition marked as "bootable" is connected to the analyzer device NANL-B500G-RE while the analyzer device NANL-B500G-RE is switched on, the netANALYZER device may not start correctly (SYS-LED is yellow).

4.2.2 Recording settings

4.2.2.1 Adjusting the buffer size

You can adjust the buffer size as follows:

- Specify the desired value in units of megabytes (MB) in the input field in the upper part of the area "Buffer settings" right of the text "Size". You have to specify an integer value here.
The minimum allowed value is 1.
The maximum allowed value is limited by the memory size of your system.

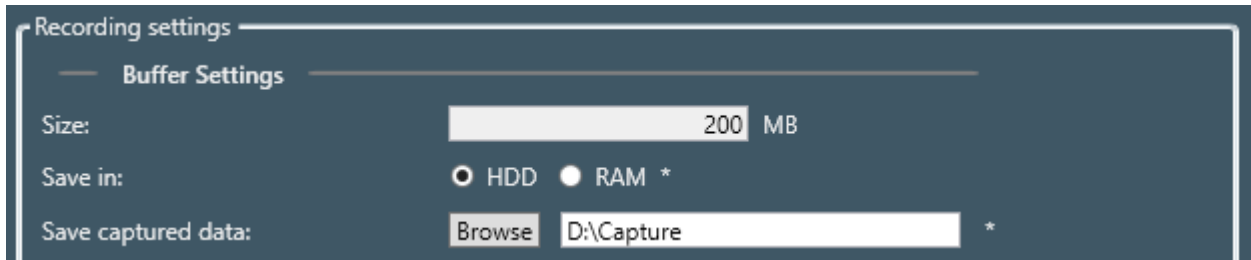

Figure 29: Adjusting the buffer size

If there is not enough disk space (at choice HDD) or internal memory (at choice RAM) available, the following error message box will appear:

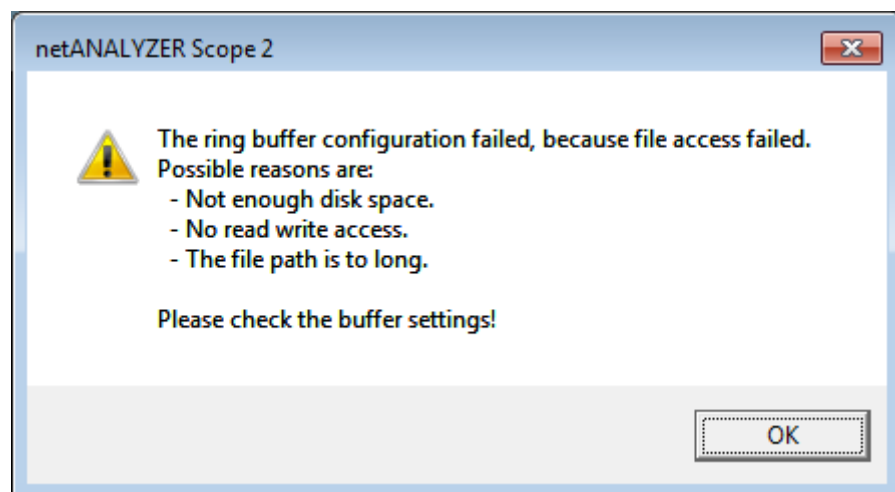

Figure 30: Error message box "Ring buffer configuration failed"

If this error message appears directly after increasing the buffer size, you should decrease this setting until the error message does not appear again or you should supply more free disk space (in case of recording to hard disk drive / Option HDD chosen).



Note:

Please take care of the respective hints on troubleshooting within chapter *Correct errors* [▶ page 252].

4.2.2.2 Selecting the recording medium

Here you can decide whether to record data on the hard disk drive (HDD) or the RAM of your computer.

- Check the respective option button HDD or RAM within the lower part of area „Buffer Settings“ of menu „Options“.
- Furthermore, you can adjust the buffer size (in MB) in input field Size and select the path to the files into which the recording is made (for option HDD).
- In order to store these settings as the valid ones, click at button *Apply settings*.

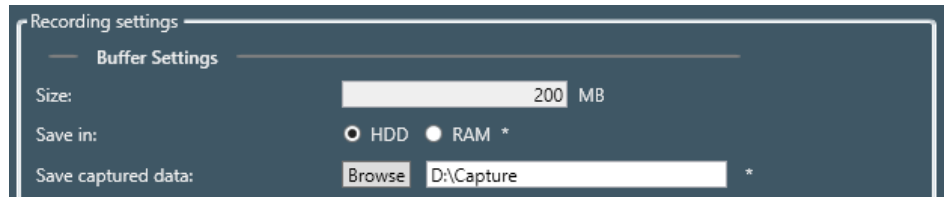

Figure 31: Selecting the recording medium

⇒ Left of the button *Apply settings* the text *Successfully* is displayed.

Choose „HDD“ if you want to store a large amount of analysis. However, then you should have the respective amount of free space on the hard disk drive of your computer.



Note:

When recording on hard disk drive (HDD) the speed of the software sometimes may be decreased. Therefore we recommend to use a hard disk drive with maximum writing and reading speed.

4.2.2.3 Define behavior at overload error

Here the behavior of the netANALYZER at overload errors can be adjusted. The selection list *Overload error* provides the following functions:

Setting	Meaning
Stop capturing	If not all frames can be processed for performance reasons, recording of data is finished.
Drop frames	If not all frames can be processed for performance reasons, some frames are rejected in a controlled manner. Sections of the recording containing rejected frames are marked in order to safely identify those parts of the recording which might be affected by data loss.

Table 11: Settings for behavior at overload error

4.2.2.4 Quicktester settings

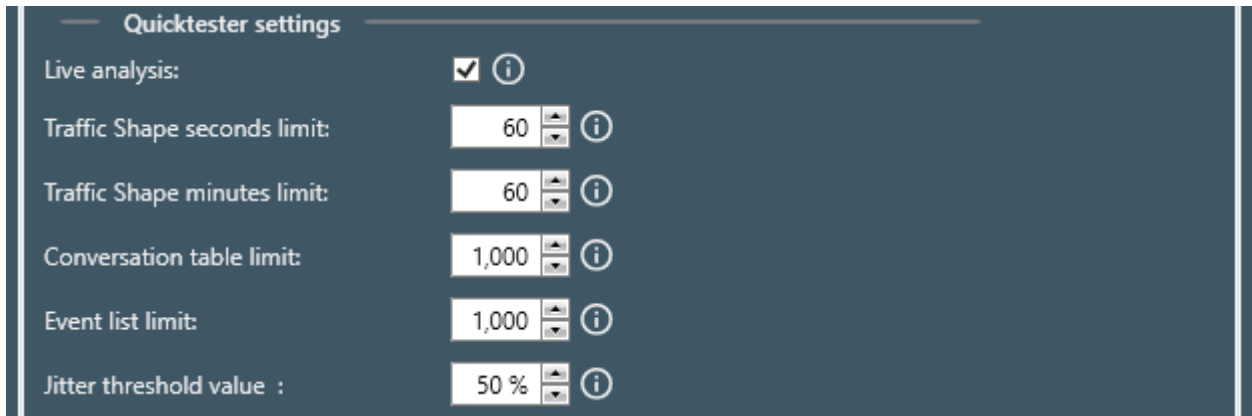

Figure 32: Quicktester settings

Option	Description
Live analysis	Activates/deactivates the live analysis Activated (default): The quicktester processes data during capturing. Deactivated: The quicktester does not process data during capturing. Use this setting to avoid performance problems.
Traffic Shape seconds limit	This is the number of seconds which are stored in the traffic shape history. When the limit is reached while capturing, older data is discarded. Value range: 60 seconds ... 600 seconds, default: 60 seconds
Traffic Shape minutes limit	This is the number of minutes which are stored in the traffic shape history. When the limit is reached while capturing, older data is discarded. Value range: 60 minutes ... 600 minutes, default: 60 minutes
Conversation table limit	Maximum number of conversations displayed in the conversation table. If the limit of conversation is reached, further detected conversations will be discarded. Value range: 1000 ... 3000, default: 1000
Event list limit	Maximum number of events in the event list. The number of data points for quicktester variables displayed in th Chart view is also limited by this value. Wertebereich: 1000 ... 10000, default: 1000
Jitter threshold value	This value defines the jitter threshold value in percent. If the jitter threshold value is exceeded, an event is generated which will then be displayed in the event list. Value range: 1 % ... 100 %, default: 50 %

Table 12: Quicktester settings

4.2.3 Indicators

4.2.3.1 Buffer fill level indicator

At the lower end of menu „Options“, there is a display of the current fill level of the recording buffer.

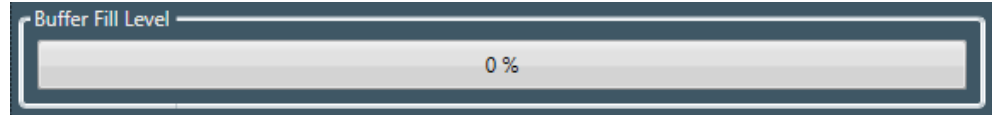

Figure 33: Buffer fill level indicator

4.2.3.2 Workload indicator

At the lower end of menu "Options", there is a per-cent display of the current workload.

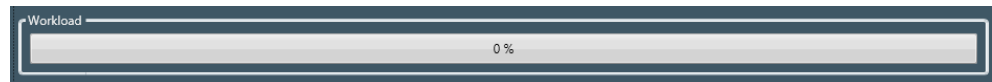

Figure 34: Workload indicator

According to the configured behavior on overload either data recording is stopped or frames are rejected if the workload amounts 100 %.

Also see about this

 Define behavior at overload error [[▶ 45](#)]

4.3 Filter settings for hardware filters

4.3.1 Dialog structure and user interface elements

When clicking at button *Details* in menu "Device assignment", a new dialog *Configuration of frame filter* opens. There you can adjust for each port separately which Ethernet frame types (and thus which protocols) will be recorded or filtered out .



Note:

The hardware filters are used to reduce the amount of recorded frames directly within the netANALYZER Hardware. Take care of the fact, that possibly required frames are not recorded if hardware filters have not properly been set causing some analysis methods such as process data analysis or event recognition not to work as expected .

The following figure shows how this dialog looks directly after opening:

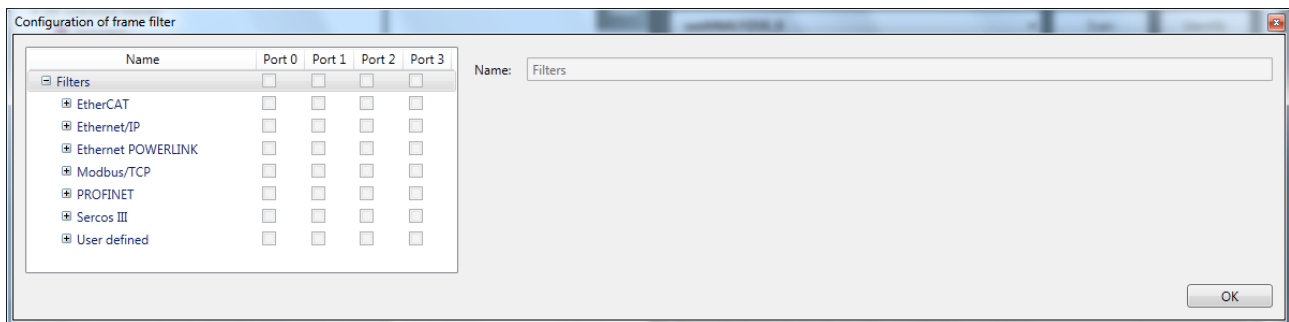

Figure 35: Dialog „Configuration of hardware filters“

The filter table is located on the left side of the dialog. In its first column, it contains a tree structure. Below the top entry *Filters*, there is an entry for each real-time Ethernet protocol. Below each protocol, there are further entries for the various frame types supported by the respective protocol. Clicking on such an element causes the user interface elements at the right side of the dialog to be displayed.

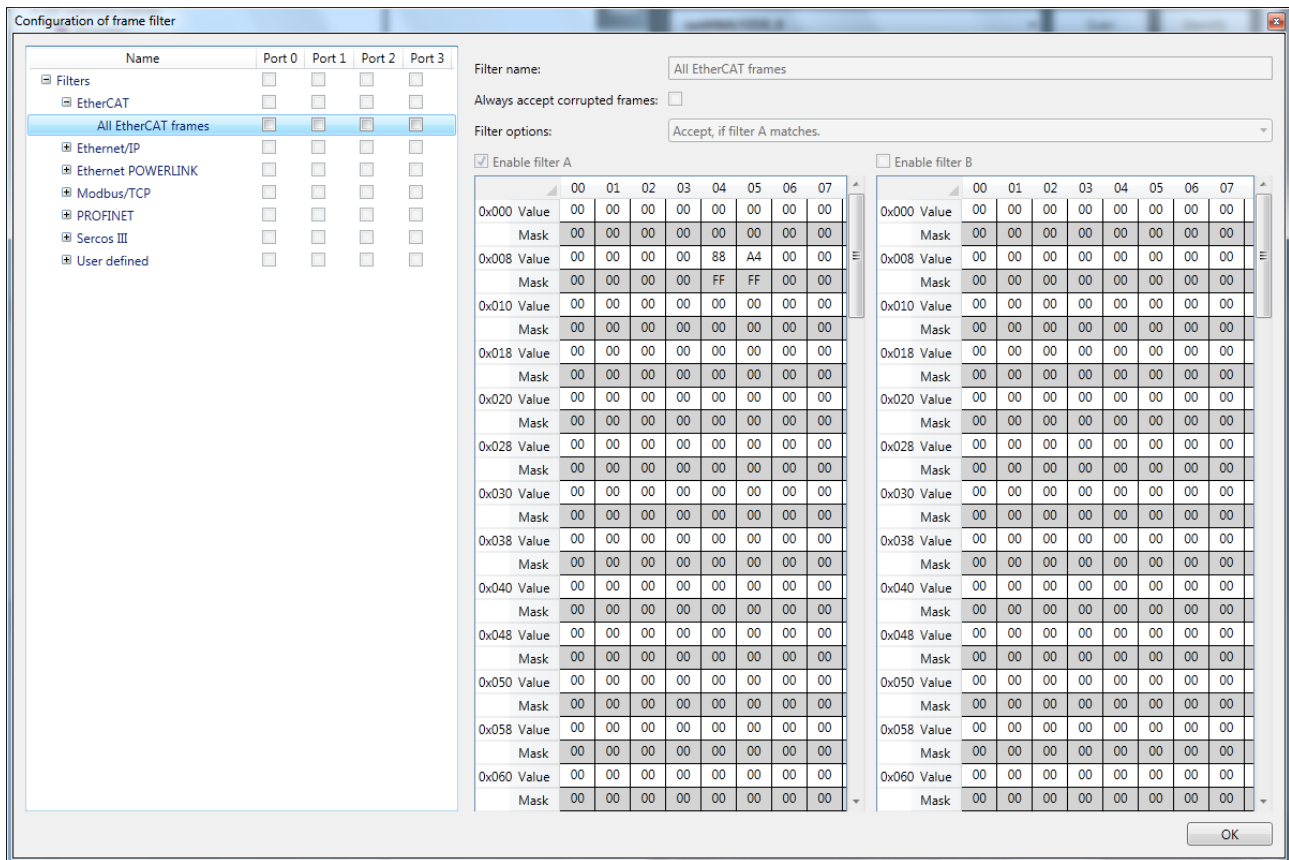

Figure 36: Dialog „Configuration of hardware filters“ (complete)

The following table explains the single elements of the user interface in the dialog "Frame filter details":

User interface element	Explanation	Range of values / Value
User interface elements of left side		
Port	For each port a checkbox in the left part of dialog Frame Filter Details. You can specify here which filter will be activated at which port.	Port 0, Port 1, Port 2, Port 3
Filters	Tree structure with predefined filters for various Ethernet protocols in the left part of the dialog <i>Frame Filter Details</i> . To store individually defined filters, you can extend the tree structure. Clicking on <i>Modbus/TCP > Exceptions</i> with the right mouse button, you can open a menu which allows you to copy, rename and delete filters.	

Table 13: Description of the user interface elements in the dialog Configuration of frame filter - User interface element on the left side

	User interface elements of right side	
Name of filter	Input field for the name of the (predefined or individually defined) filter. The field is located in the topmost right part of the dialog. Only for individually defined filters the name of the filter can be edited.	
Always accept corrupted frames	By checking this box, the filter accepts frames even if they are corrupted and should normally be blocked. This checkbox is located in the upper right part of the dialog just below the name of the filter..	
Filter Options	Selection list containing the possible combinations of the following filter options 1. Accept or reject value 2. Filter A and/or Filter B (if two filters are used) 3. Value must match / must not match Depending on the chosen filters, the list field contains different options. This selection list is located in the upper right part of the dialog below the checkbox. See Applicable filter options.	
Enable Filter A Enable Filter B	Checkboxes for filter definitions: Filter A or Filter B or Filter A and B" Note: All predefined filters are write-protected.	checked: Filter A, Filter B, Filter A and Filter B
Filter matrix (2x)	Input matrix for specifying value and mask bytes for each the first 512 bytes of the Ethernet frame (applies only for individually defined filters, otherwise display of current settings only).	1-512 byte
Wert	Comparison value for checking the frame contents bitwise (taking into account the mask) Input is expected in hexadecimal format	0 ... 0xFF
Maske	Filter mask Value = 0: Contents of value bit not taken into account in bitwise comparison Value = 1: Contents of value bit is taken into account in bitwise comparison Input is expected in hexadecimal format	0 ... 0xFF

Table 14: Description of the user interface elements in the dialog Configuration of frame filter
- User interface element on the right side

4.3.2 Ethernet Frame Filter

Filters are used to reduce the amount of data or for precise choice of analysis data. For known frame types of commonly used protocols, predefined filter masks can be applied. On the other hand, individual filter masks can be defined, if necessary.

For each of the four Ethernet-Ports (Port 0 to port 3) in the netANALYZER hardware an Ethernet frame filter can be individually defined at the left side. These hardware filters are preceding the software filters.

During filtering the first 512 data values (“filter elements”) within the Ethernet frame are compared with specified values (line “value”) of the filter matrix. These are displayed and edited in groups consisting of 8 byte each within the filter matrix, see following examples.

For each filter element, the value to be compared and additionally a mask can be specified there. With this mask the comparison can be restricted to the bits set in the mask.

The first 512 byte of the frame contains

- the Target MAC address (byte 0 to 5),
- the Source MAC address (byte 6 to 11),
- the Ether-Type (byte 12 and 13), and
- the first 498 bytes of the payload (the actually usable frame data).

4.3.3 Predefined filters

A lot of predefined filters are available In order to detect nearly all common Real-Time Ethernet frame types used in automation. The following table shows which predefined filter types are available for which Real-Time Ethernet protocol.

Protocol	Frame filter
EtherCAT	All EtherCAT frames
EtherNet/IP	Cyclic Frames
	Acyclic Frames
	DLR protocol messages
Ethernet Powerlink	Poll request/ response frames
	Asynchronous send (ASnd)
	SDO frames
Modbus/TCP	Modbus/TCP frames
	Exceptions
PROFINET	Alarms
	Sync frames
	Delay frames
	LLDP frames
	MRP frames
Sercos	MDT
	AT
	S-Channel
	P-Channel
	CP0
	CP1
	CP2
	CP3
	CP4

Table 15: Predefined Ethernet Frame filters

All predefined filters are write-protected. This means, for predefined filters the specifications at „Mask“- and „Value“ below Enable Filter A and Enable Filter B cannot be changed.

4.3.4 Individually defined filters

If these options to define filters are not yet sufficient, you can also define individual filters of your own. These individually defined filters appear in a separate line in the table at the left part of the dialog. There are three possibilities to define these:

1. Selection of the lowest entry *User defined/(blank)* in the tree structure at the left side

Here an editable table line is already available.

1. Context menu function *New*
2. A new line is created in the filter table within the left part of the dialog. For the filter represented by this line, you can edit the specifications on the right side of the dialog. There you can specify the name and perform all necessary settings.
3. Context menu function *Paste*

Prerequisite for this is that you have already copied a new table line using context menu function *Copy*. A new line is created and all settings will be applied in this line. This also includes the name of the previously copied line.

As soon as an editable line has been created or selected within the filter table, the previously disabled input options on the right side will be activated. These are:

1. Input field *Filter name*
2. Checkbox *Always accept corrupted frames*
3. Selection list *Filter options*
4. Checkboxes *Enable Filter A* and *Enable Filter B*
5. Filter matrix for the *value* and the *mask* for all filter elements (0...511)

These user interface elements are described below *Description of the user interface elements in the dialog Configuration of frame filter - User interface element on the left side* [► page 49], see there.

Input into the filter matrix is accomplished as described in subsection *Defining and storing filter settings*.

4.3.4.1 Applicable filter options

At one time, up to two separate filter conditions can be checked.

The options offered in selection list *Filter options* depend on the status of the checkboxes *Enable Filter A* and *Enable Filter B* (i.e. whether these have been checked or not).

The rules for evaluating the condition allow to accept or reject the value depending on whether a match occurred when checking the frame with the specified values, or not. If two filters are involved, either an *AND* or an *OR* operation can be applied to results.

Thus, the following filter options are applicable:

Enable Filter A	Enable Filter B	Meaning
X	X	Accept, if filter A matches and filter B matches.
X	X	Accept, if filter A doesn't match and filter B matches.
X	X	Accept, if filter A matches and filter B doesn't match.
X	X	Accept, if filter A doesn't match and filter B doesn't match.
X	X	Accept, if filter A matches or filter B matches.
X	X	Accept, if filter A doesn't match or filter B matches.
X	X	Accept, if filter A matches or filter B doesn't match.
X	X	Accept, if filter A doesn't match or filter B doesn't match.
X	X	Reject, if filter A matches and filter B matches.
X	X	Reject, if filter A doesn't match and filter B matches.
X	X	Reject, if filter A matches and filter B doesn't match.
X	X	Reject, if filter A doesn't match and filter B doesn't match.
X	X	Reject, if filter A matches or filter B matches.
X	X	Reject, if filter A doesn't match or filter B matches.
X	X	Reject, if filter A matches or filter B doesn't match.
X	X	Reject, if filter A doesn't match or filter B doesn't match.
X		Accept, if filter A matches.
X		Accept, if filter A doesn't match.
X		Reject, if filter A matches.
X		Reject, if filter A doesn't match.
	X	Accept, if filter B matches.
	X	Accept, if filter B matches.
	X	Reject, if filter B matches.
	X	Reject, if filter B matches.

Table 16: Applicable filter options

4.3.4.2 Checkboxes Enable Filter A and Enable Filter B

These checkboxes are located in the right part of the dialog below selection list *Filter options* and above both filter matrices. Here you can decide, whether filter A (left filter matrix) or filter B (right filter matrix) is used.

4.3.5 Context menu functions

You open the context menu of the filter table by clicking on it with the right mouse button.

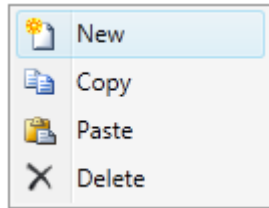

Figure 37: Context menu of filter table

The following functions are available:

New	Insert a new line into the table
Copy	Copy a table line
Paste	Paste copied line into the table
Delete	Delete a line within the table

Table 17: Context menu functions

4.3.6 Defining and storing filter settings

To define filter settings for one or several filters, proceed as follows:

1. Create a new line in the filter table. You can do this using context menu function "New" for instance.
2. Activate checkbox *Enable Filter A* or *Enable Filter B* or both!
3. For the respective filter element (0...511), specify the value to be bitwise compared in row *Value* (Input in hexadecimal format, range of values from 00 to FF, a mask can be applied restrict the bitwise comparison to some selected bits.)
4. Specify the desired mask for each filter element (0...511) to be changed in the line *Mask*. Setting a bit to 0 in the mask will cause the respective bits of the filter element to be irrelevant..

Value in Mask	Value used in filtering
FF	The input in field Value will be used in filtering.
00	The input in field Value will not to be used in filtering. the affected filter element will not be filtered at all.
0F	The lower four bits in field Value will be applied in filtering.
F0	The upper four bits in field Value will be applied in filtering.

Table 18: Some common values used for filtering (Line Value)

(Input in hexadecimal formats, range of values from 00 to FF.)

Store the current filter configuration by clicking at the *Ok* button.

Two examples follow:

Example 1:

This example defines a filter which only allows Ethernet frames to be recorded that begin with 00, 15, CF.

	Target MAC address						Source MAC address						Data type		Payload	
Byte	0	1	2	3	4	5	6	7	8	9	10	11	12	13	14	15
Value	00	15	CF	DD	DA	BE	00	00	00	00	00	00	00	00	00	00
Mask	FF	FF	FF	00	00	00	00	00	00	00	00	00	00	00	00	00

Table 19: Example: Filter definition

In order to implement this filter, proceed as follows:

- Check *Enable Filter A*.
- Specify these values in filter matrix A.
- Do not activate checkbox *Always accept corrupted frames*. Otherwise, corrupted frames will always pass the filter then, even if they had normally been recognized to be filtered out.
- Choose a combination of filter options from the selection list *Filter options*.
Depending on your choice, the list field will contain different selection options.
- Store the current filter configuration by clicking at the *Ok* button.

Example 2:

The example shows a filter detecting Sercos CP3 frames.

	Target MAC address						Source MAC address						Data type		Payload	
Byte	0	1	2	3	4	5	6	7	8	9	10	11	12	13	14	15
Value	00	00	00	00	00	00	00	00	00	00	00	00	88	CD	00	03
Mask	00	00	00	00	00	00	00	00	00	00	00	00	FF	FF	00	0F

Table 20: Example: Filter definition

Define, store and restore filter settings

- Check *Enable Filter A*.
- Specify these values in filter matrix A.

Enable filter A

	00	01	02	03	04	05	06	07
0x000 Value	00	00	00	00	00	00	00	00
Mask	00	00	00	00	00	00	00	00
0x008 Value	00	00	00	00	88	CD	00	03
Mask	00	00	00	00	FF	FF	00	0F
0x010 Value	00	00	00	00	00	00	00	00
Mask	00	00	00	00	00	00	00	00
0x018 Value	00	00	00	00	00	00	00	00
Mask	00	00	00	00	00	00	00	00
0x020 Value	00	00	00	00	00	00	00	00
Mask	00	00	00	00	00	00	00	00
0x028 Value	00	00	00	00	00	00	00	00
Mask	00	00	00	00	00	00	00	00
0x030 Value	00	00	00	00	00	00	00	00
Mask	00	00	00	00	00	00	00	00
0x038 Value	00	00	00	00	00	00	00	00
Mask	00	00	00	00	00	00	00	00
0x040 Value	00	00	00	00	00	00	00	00
Mask	00	00	00	00	00	00	00	00
0x048 Value	00	00	00	00	00	00	00	00
Mask	00	00	00	00	00	00	00	00
0x050 Value	00	00	00	00	00	00	00	00
Mask	00	00	00	00	00	00	00	00
0x058 Value	00	00	00	00	00	00	00	00
Mask	00	00	00	00	00	00	00	00
0x060 Value	00	00	00	00	00	00	00	00
Mask	00	00	00	00	00	00	00	00

Figure 38: Example 2

- Do not activate checkbox *Always accept corrupted frames*. Otherwise corrupted frames will then always pass the filter, even if they had normally been recognized to be filtered out.
- Choose a combination of filter options from the selection list *Filter options*. Depending on your choice, the list field will contain different selection options.

Storing filter settings

To store filter settings:

- Close the current filer by clicking at **Ok**.

5 Recording Data

This section describes how to use netANALYZER Scope for recording data.



Buttons from side menu	Step	Description
 Connect	1	Build up a connection For PROFINET: Supervision of start-up phase of PROFINET communication
 Start	2	Starts recording data
 Stop	3	Stopping recording
 Disconnect	4	Disconnect: For PROFINET: PROFINET information from start-up is no longer used

Table 21: Buttons for recording control

Requirements

In order to record Ethernet data with netANALYZER Scope, the following requirements must be fulfilled.

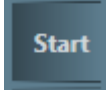
- A connection to a netANALYZER is build up. As long as this condition is not fulfilled, the button **Start** in the side menu is grayed out and inactive.
- If PROFINET data are to be recorded, the start-up phase of the communication between PROFINET IO-Controller and IO-Device must have been recorded, too. To do so, a connection must have been established and the start-up phase must have happened (see *Start-up of PROFINET communication* [▶ page 79]).
- For long-time recordings the power options of Microsoft Windows® have to be adjusted in such a way that no interference with the recording may occur.

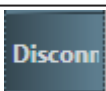
Stopping recording

Recording of Ethernet frames continues without any time limit until one of the following conditions is met:

- Recording is stopped manually
- A previously defined trigger condition is met and data recording is automatically stopped.

As long as none of this conditions has been fulfilled, the recording of data is continued without any time limit. The limited space in memory provided for the buffer will also not cause recording to be finished as the buffer is organized as a ring buffer. At buffer overflow, the oldest recorded data are overwritten.

At the stop of the recording process, an informative message including a current timestamp is sent to the *At the stop of the recording process, an informative message including a current timestamp is sent to the Message Output Area* [► page 31].

Settings of the power options of Microsoft Windows for long-time recordings

Depending on the current setting of the power options of Microsoft Windows the PC may change to the standby state on its own. For instance, if you use the default power profile “Balanced (recommended)”, the connection to the netANALYZER will be lost after approx. 30 minutes and a long-time recording would in this case be aborted unintendedly.

So if you intend to perform a long-time measurement with netANALYZER Scope, you must inhibit this:

- In order to do so, select the option “High performance” within the power options of Microsoft Windows
- ⇒ This prevents the PC to change to standby state during the recording takes place.



Note:

For more information concerning the power options refer to the documentation or online help of Microsoft Windows.

5.1 Define triggers to stop recording

In order to define conditions for stopping recordings of Ethernet frames, netANALYZER Scope allows to define one or multiple trigger events.

This gives you the opportunity to find the interesting information you are looking for much easier as it will be located relatively short before the end of the recording if the trigger definition has been done appropriately. Even complicated situations should easily be reproduced by an appropriate definition of trigger conditions.

You can accomplish this within the trigger view.

**Note:**

For more information on defining triggers, read chapter *Trigger view* [▶ page 194].

6 Project administration

This chapter describes how to work with projects using the Project Menu Pane of the Main Menu of netANALYZER Scope. A project is used for managing the user-defined views and other user settings and for storing of configuration information concerning the EtherCAT or PROFINET devices within the network to be analysed. This includes:

- Creating new projects
(see section *Create a new project* [▶ page 62])
- Saving existing projects
(see section *Save an existing project* [▶ page 64])
- Loading saved projects
(see section *Load a saved project* [▶ page 65])

Project file formats

Beginning with netANALYZER Scope V2 the new compressed project file format *.nsprj is used.



Note:

This chapter does not deal with the import of network description files such as *.eni or *.gsd files as you might expect.

Project menu

The project menu of netANALYZER Scope looks like this:

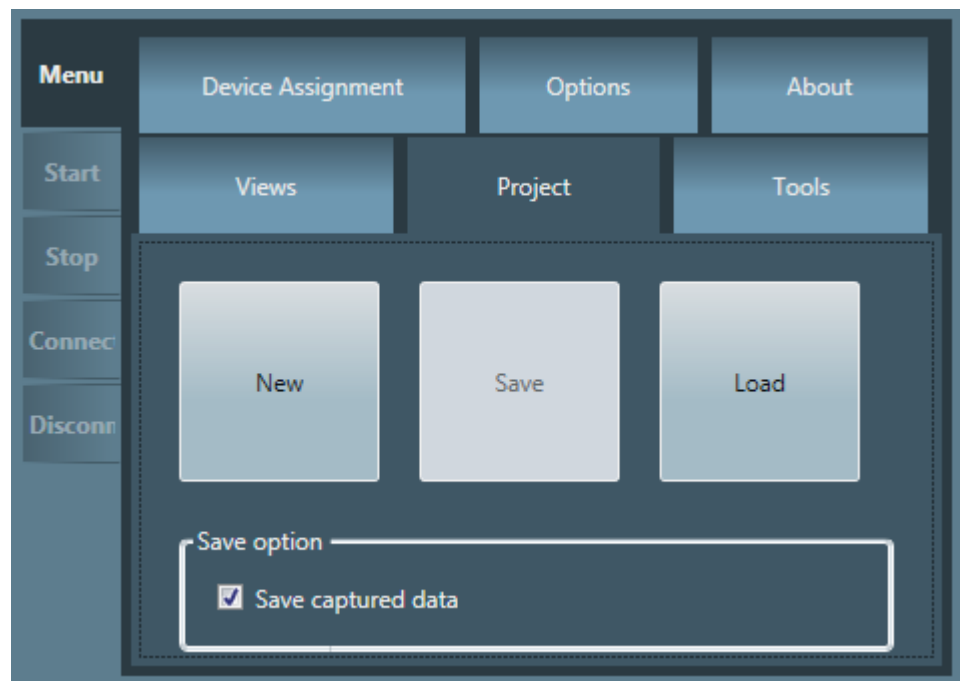

Figure 39: Menu pane Projects

6.1 Create a new project

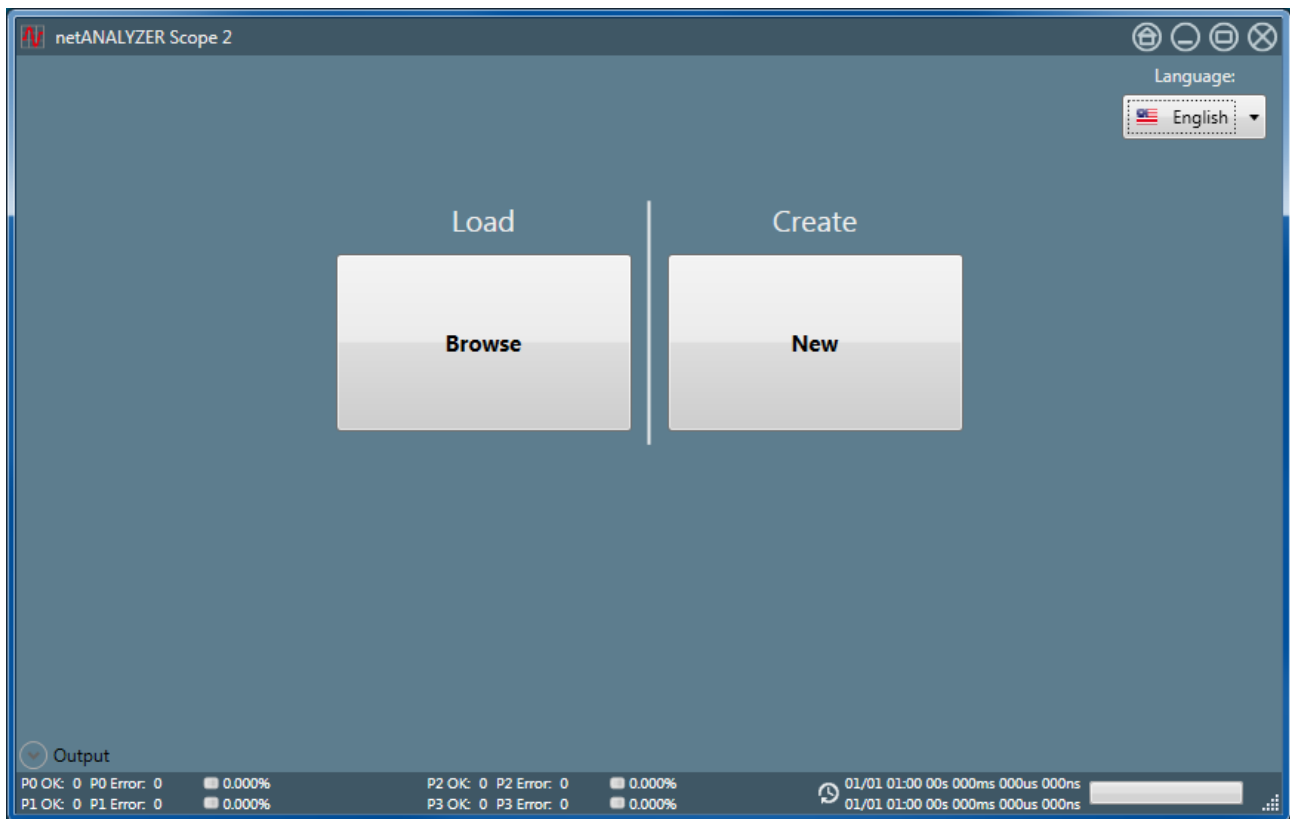



Figure 40: Start menu netANALYZER Scope

1. In order to create a new project, if netANALYZER Scope is already opened:
 - Click at *New* within the project menu (Register card Project). (The language currently set for the user interface is used.)
2. Alternatively (from the beginning):
 - Open the entry screen of netANALYZER Scope. To do so, either start netANALYZER Scope or if netANALYZER Scope has already been opened, click at the Close icon (Icon ) in the upper icon bar and answer the subsequent safety request dialog.
 - The entry screen of netANALYZER Scope is displayed now, see entry screen of netANALYZER Scope and section *Start screen* [▶ page 22].
 - ⇒ Check whether the desired language for the project has already been selected, and change the selection if necessary using the selection list in the upper right corner of the start menu (according to section *Select language* [▶ page 23]).

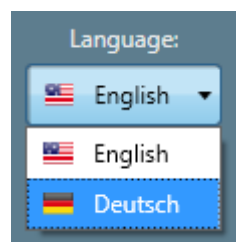

Figure 41: Language selection list

- Click at *New* in area **Create**.
- ⇒ Now, the project is created.

**Note:**

How to accomplish this, is described in section *Using views for analysis* [▶ page 90].

6.2 Save an existing project

1. In order to save an already existing project in netANALYZER Scope :
 - Click at **Save** in the project menu of netANALYZER Scope:
 - ⇒ The file selection dialog for saving the project is opened:

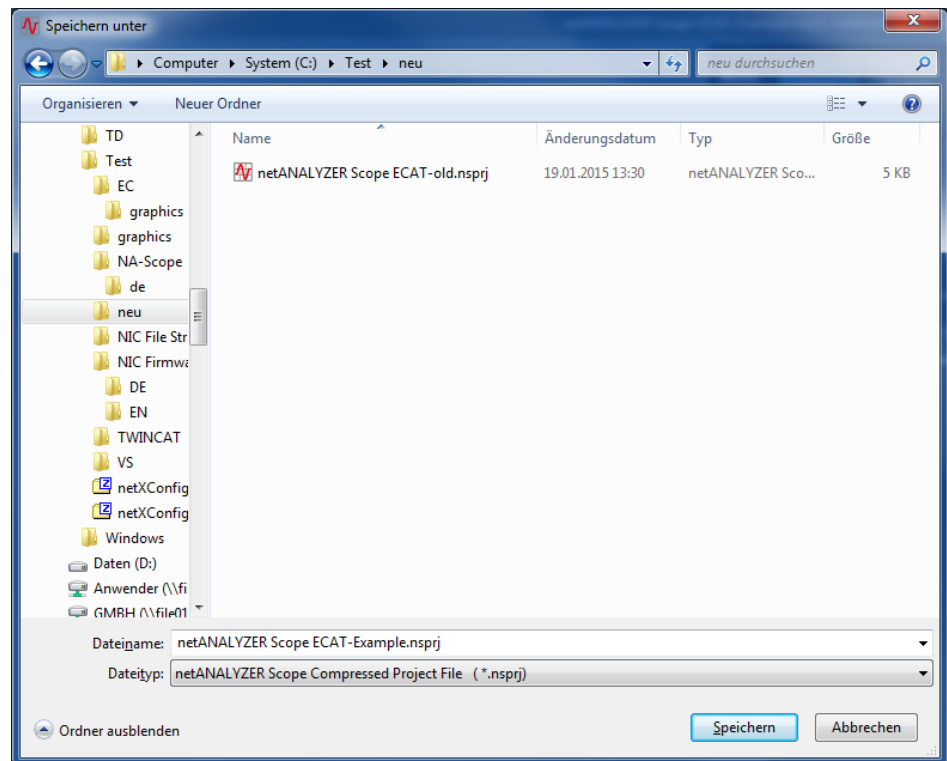

Figure 42: Dialog Box "Save Project"

- Choose the desired *.nsprj file for saving or specify a new project name in the field Dateiname. Always use the proposed data type *.nsprj.
- Choose the desired save option (see below).
- Click at **Save**.
- ⇒ The project file and folder contents has been saved now under the chosen project name. It is available to be loaded again whenever you intend to reuse the project. If already a file with this name exists, a request box will ask, whether this file shall be overwritten.

6.2.1 Save option

By checking **Save captured data** in the box titled Save Option in the menu pane *Project*, you can decide about the amount of data storage within the project file and directory:

- If checked, the recorded data and the project settings are saved..
- If not checked, only the project settings are saved in the project file.

6.3 Load a saved project

netANALYZER Scope V2 supports netANALYZER Scope compressed project files *.nsprj (default in netANALYZER Scope V2).

1. In order to load a previously saved project with netANALYZER Scope:
 - If netANALYZER Scope already is opened:
 - Click at *Load* in the project menu of netANALYZER Scope :

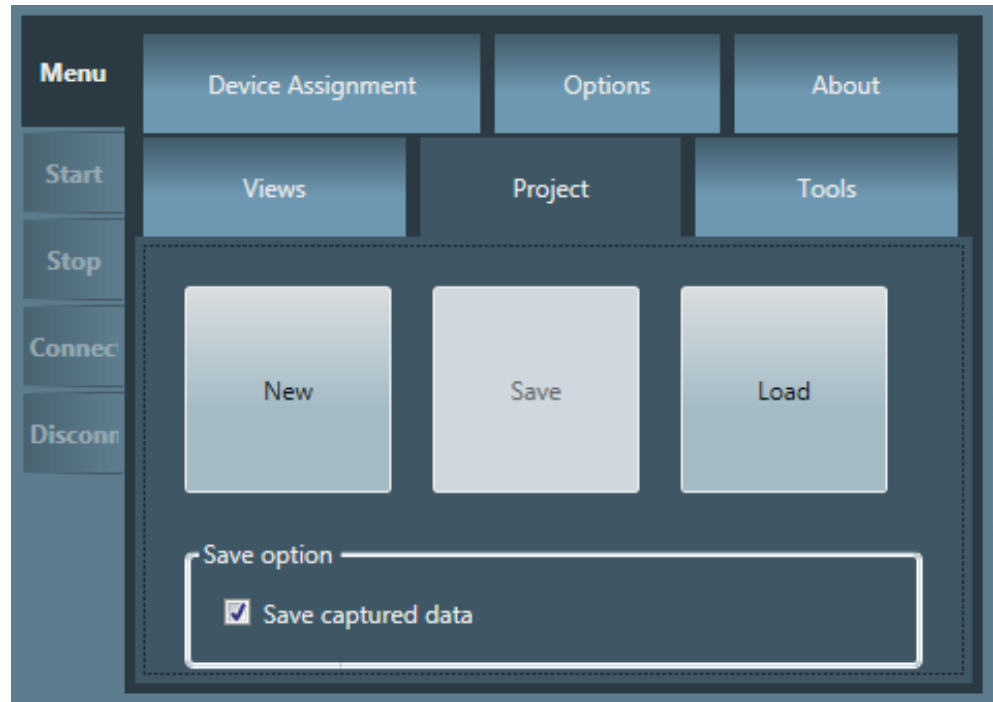

Figure 43: Menu pane Projects

-
- A selection dialog for loading the project file will appear:

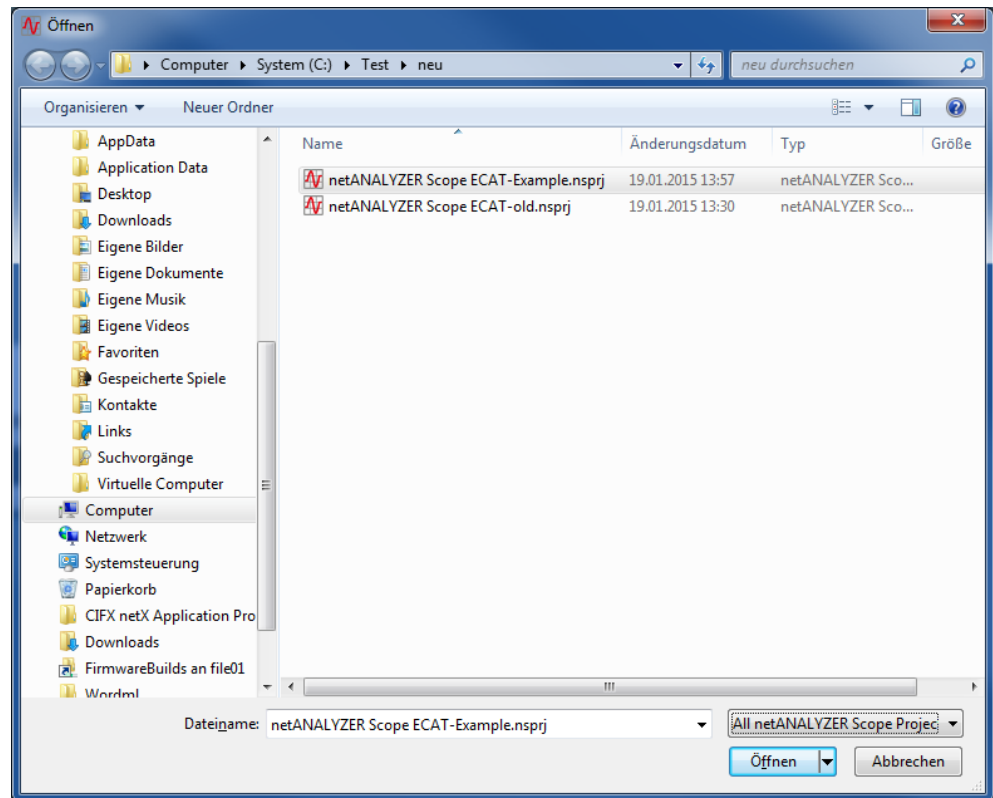

Figure 44: File selection dialog for loading the project file

- If you want to load a netANALYZER Scope compressed project file:
Select the *.nsprj file for the desired project to be loaded within that file selection dialog.
- ↗ The project is loaded now and the already opened views are displayed.

If netANALYZER Scope has not been opened previously:

- Start netANALYZER Scope.
- ↗ The entry screen of netANALYZER Scope is displayed now, see section *.Start screen* [▶ page 22]

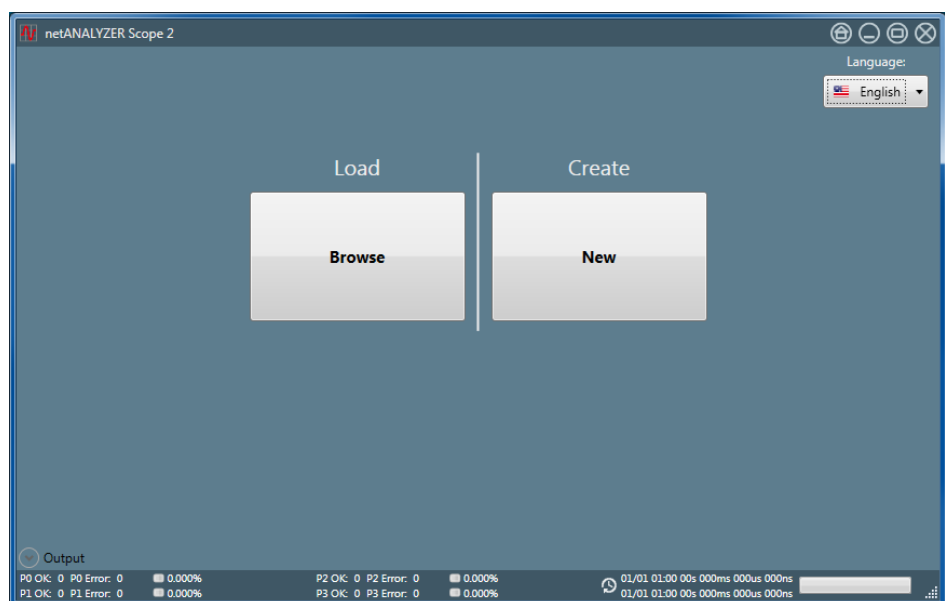

Figure 45: Start menu

- Change the language selection if necessary using the selection list in the upper right corner of the start menu (according to section *Select language* [▶ page 23]).



Figure 46: Language selection list

- Click at *Browse* in the area **Load**.
- ⇒ A file selection dialog for loading the project file will appear:

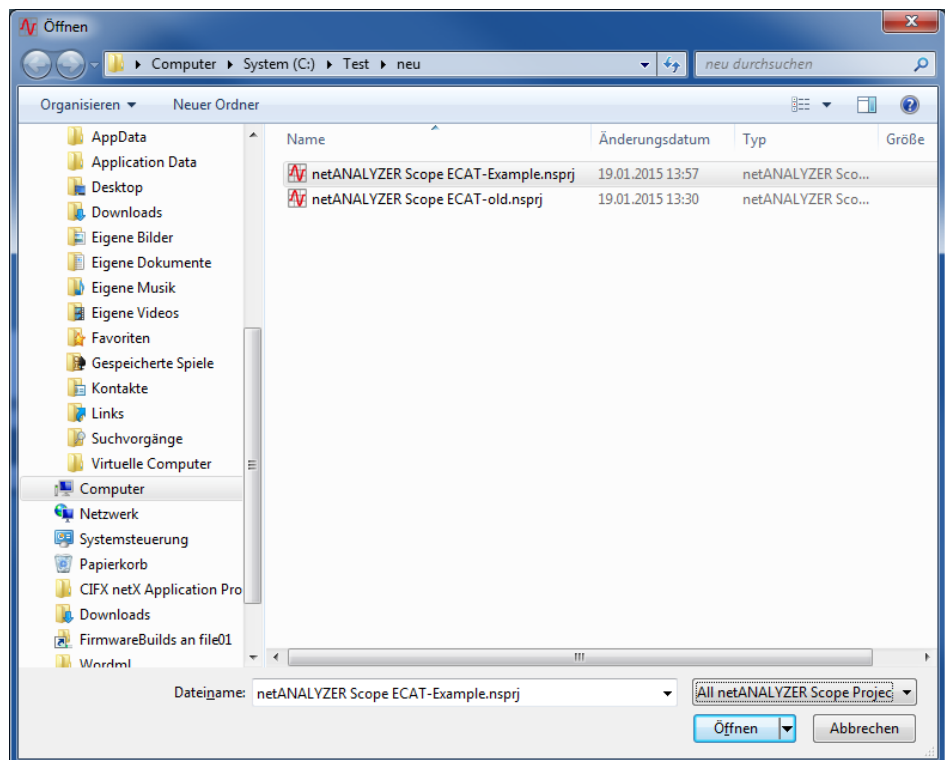

Figure 47: File Selection Dialog for loading the Project File

- If you want to load a netANALYZER Scope compressed project file: Select the *.nsprj file for the desired project to be loaded within that file selection dialog.
- ⇒ The project is loaded now and the already opened views are displayed.
- ⇒ The file selection dialog allows to display only one or both kinds of project file. This can be selected in the lower right corner of the dialog.



Note:

How to work with views is described in section "*Using views for analysis* [▶ page 90]".

In case of the project file being damaged or incompatible with netANALYZER Scope V2, the following error message will be issued:

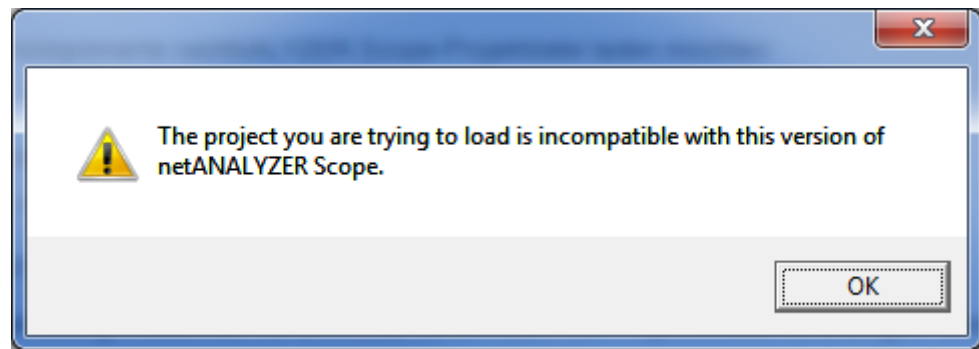

Figure 48: Error Message "Incompatible project"

If the following error message is displayed after opening a project file:

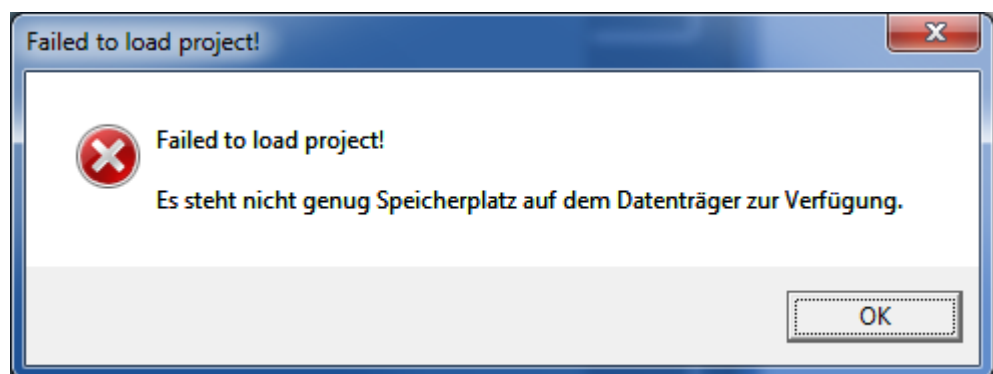

Figure 49: Error message box "Failed to load project"

- Reduce the setting for the buffer size in menu "Options".
- Try to load the project file again.

If the dialog *Configuration assistant* appears, follow the instructions in the subsequent section *The configuration assistant* [▶ page 69].

6.4 The configuration assistant

The configuration assistant appears always when loading a *project file* [▶ page 65], if there is a mismatch between the currently used device settings and the settings loaded from the project file.

Below an example for a configuration assistant dialog showing many differences between the current and the loaded settings.

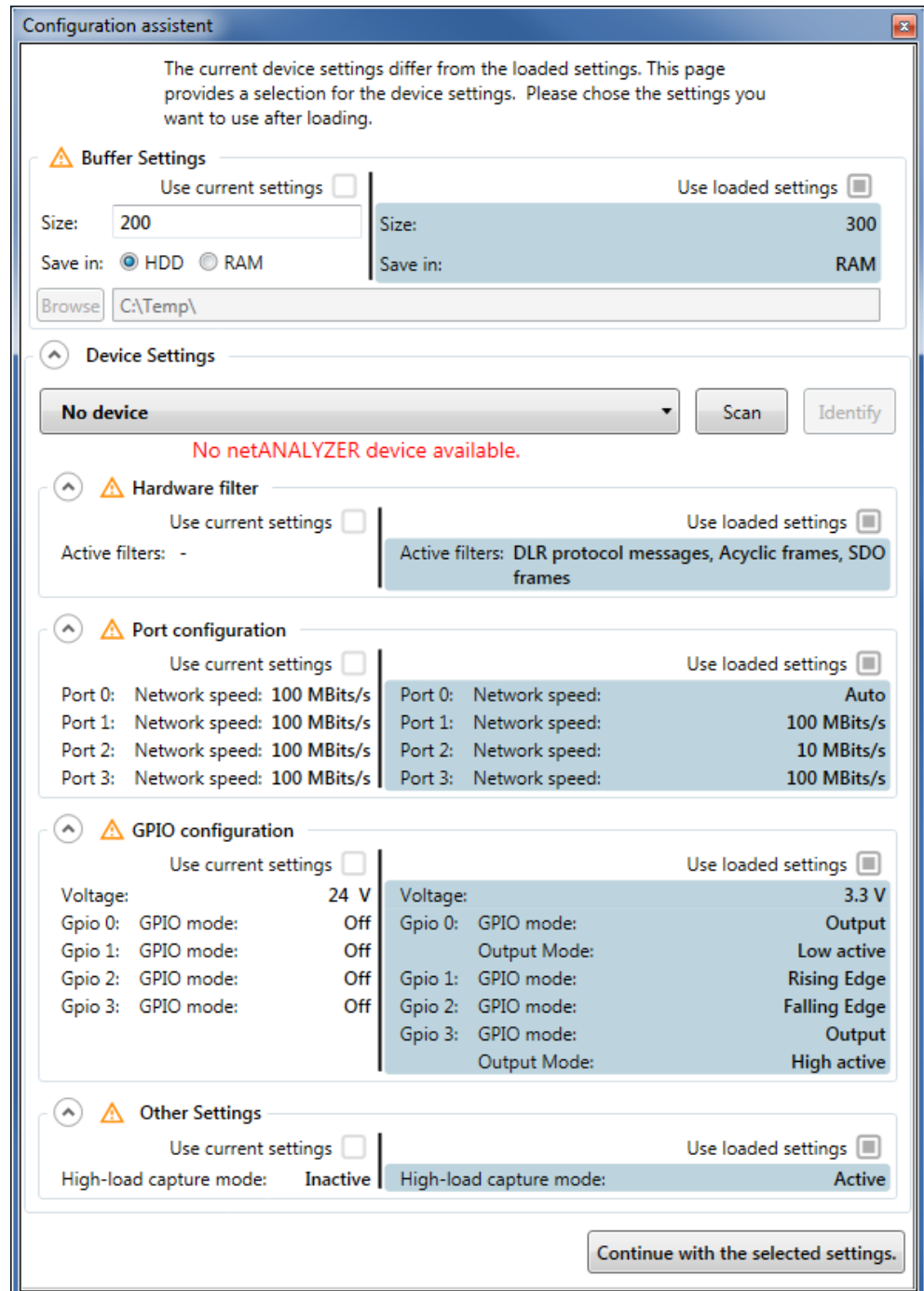

For all displayed differences the following is valid:

You can choose, whether the current configuration (Radio button "*Use current settings*") or the configuration loaded from the project file (Radio button "*Use loaded settings*") shall be used. Differences of the following settings may be displayed here:

Buffer settings

Here, the current and the loaded settings concerning the buffer configuration are opposed.

- Size (Buffer size, numeric value in units of MB)
- Save in (Recording mode, possible options:HDD for harddisk recording or RAM for recording to main memory)
- Path for buffer files

Hardware filters

Here, the current and the loaded settings concerning the hardware filters are opposed.

The filters listed in the table in subsection Predefined filters can be active or inactive.

Port configuration

Here, the current and the loaded settings concerning the port configuration are opposed.

For port 0, 1, 2 and 3 each the network speed is displayed. Possible value are Auto, 10 MBit/s and 100 MBit/s.

GPIO configuration

Here, the current and the loaded settings concerning the GPIO configuration are opposed.

For GPIO 0, 1, 2 and 3 each, the GPIO mode, the output mode and the voltage is displayed.

Possible values are:

- For the GPIO mode
 - Out
 - Rising edge
 - Falling edge
 - Output
- For the output mode:
 - High active
 - Low active
- For the voltage:
 - 24 V
 - 3.3 V

Other settings

Here, the current and the loaded settings concerning the high-load capture mode are opposed.

- High-load capture mode (active/ inactive).

Besides the radio buttons for selecting the current or loaded settings, the following controls are available in the configuration assistant:

Device selection list

The device selection list in the configuration assistant has the same function as the device selection list in dialog “Device assignment”, see Assigning a device.

Buttons Scan and Identify

As well, the buttons **Scan** and **Identify** are available with the same function as described there.

Button Continue with the selected settings

In order to continue with loading the data and opening the views:

- Click at the button “Continue with the selected settings”.

7 Analyzing EtherCAT frames

This section describes the EtherCAT-specific aspects of the configuration of netANALYZER Scope .

This section has the following topics:

- EtherCAT datagram structure
- Definition of signal directions
- List of Commands
- List of supported data types for variables
- List of EtherCAT Items

7.1 EtherCAT datagram structure

The following figure show the structure of the EtherCAT Datagram:

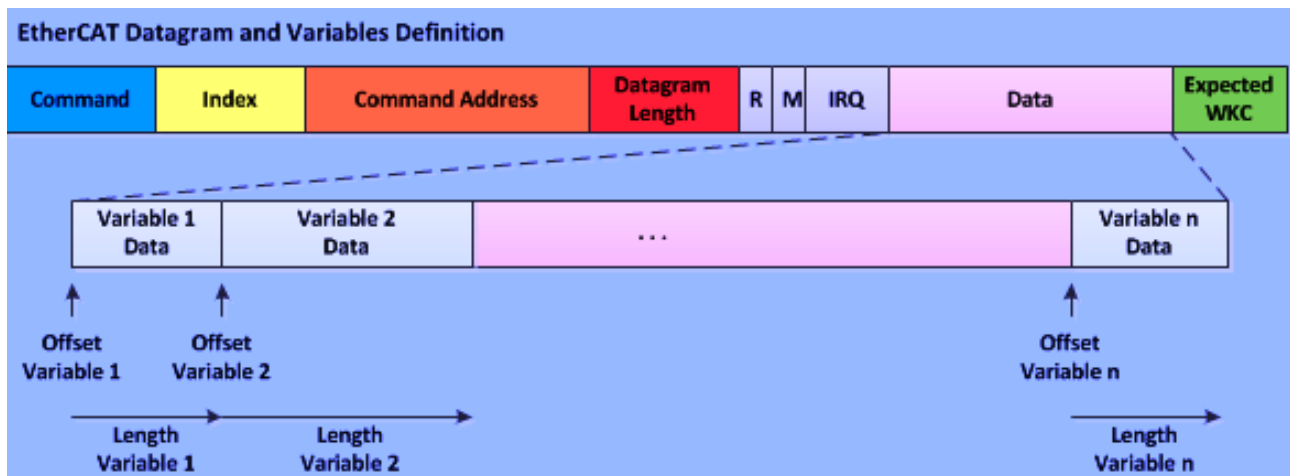

Figure 50: Structure of EtherCAT Datagram

The elements of the EtherCAT datagram have the following meaning:

Datagram element	Description
Command	This element of the EtherCAT datagram contains the information how which slave should access to the Process Data Unit (PDU), see <i>List of EtherCAT commands</i> [▶ page 75]).
Index	Master-specific parameter
Command Address	This element of the EtherCAT datagram contains the address of the data the command will affect. Various addressing modes are available, see section <i>List of EtherCAT commands</i> [▶ page 75]).
Datagram length/flags	11 bits (bit 0-10) of the 16-bit large element of the EtherCAT Datagram specify the length of the data field in bytes (limited to a maximum size of 1468 bytes). Bit 11-13 are reserved ("R"). Bit 14 is "Circulating". Bit 15 contains the More flag "M" indicating that another EtherCAT Datagram follows.
IRQ	Used internally
Data Field	The data field contains the data to be transferred with the EtherCAT datagram. The length of the data field is limited to a maximum size of 1486 bytes.
Expected Working Counter	This element of the EtherCAT Datagram contains the expected value for the working counter on return.
Datagram element	Description

Table 22: Meaning of Elements of EtherCAT Datagram

7.2 Definition of signal directions

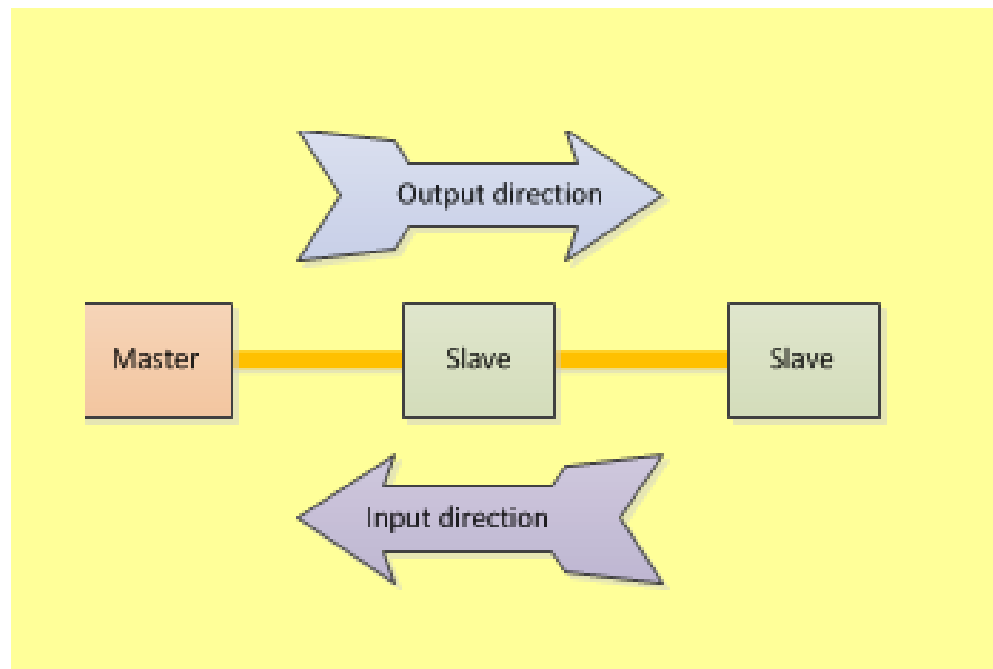

Figure 51: Signal directions in EtherCAT

In EtherCAT, the signal directions are defined as follows:

- Input means data are transferred from the EtherCAT Slaves to the EtherCAT Master.
- Output means data are transferred from the EtherCAT Master to the EtherCAT Slaves.

7.3 List of EtherCAT commands

The following EtherCAT commands are defined within the EtherCAT specification:

Command Code	Command
APRD	Auto increment physical read
APWR	Auto increment physical write
APRW	Auto increment physical read write
FPRD	Configured address physical read
FPWR	Configured address physical write
FPRW	Configured address physical read write
BRD	Broadcast read
BWR	Broadcast write
BRW	Broadcast read write
LRD	Logical read
LWR	Logical write
LRW	Logical read write
ARMW	Auto increment physical read multiple write
FRMW	Configured address physical read multiple write

Table 23: EtherCAT Command Codes

Also refer the EtherCAT specification (reference [2]).

These commands differ in the addressing method used:

- DAuto increment access (APRD, APWR, APRW, ARMW) uses an automatically incremented position located in the first 16 bits of the command address and a local memory address as offset (last 16 bits of command address).
- (Fixed) configured address access (FPRD, FPWR, FPRW, FRMW) uses a configured address and a local memory address as offset located in the last 16 bits of command address.
- Broadcast access (BRD, BWR, BRW) uses a position (first 16 bits of command address) and a local memory address as offset located in the last 16 bits of command address. The position is incremented by each slave at BRD.
- Logical access (LRD, LWR, LRW) uses 32-bit logical addresses.

7.4 List of supported data types for variables

The following data types are supported in variables of EtherCAT Master and Slave devices.

Data type name	Description	Bit length	Value range
BOOLBIT	'0': FALSE '1': TRUE	1	0 ... 1 (FALSE, TRUE)
BIT1		1	
BIT2		2	
BIT3		3	
BIT4		4	
BIT5		5	
BIT6		6	
BIT7		7	
BIT8		8	
SINT	Short integer	8	-128 ... 127
INT	Integer	16	-32768 ... 32767
INT24		24	
DINT	Double integer	32	$-2^{31} \dots +2^{31}-1$
INT40		40	
INT48		48	
INT56		56	
LINT	Long integer	64	
USINT	Unsigned short integer	8	0 ... 255
UINT	Unsigned integer/Word	16	0 ... 65535
UINT24		24	
UDINT	Unsigned double integer	32	0 ... $+2^{32}-1$
UINT40		40	
UINT48		48	
UINT56		56	
ULINT	Unsigned long integer	64	0 ... $+2^{64}-1$
REAL	Floating point	32	
LREAL	Long Float	64	
VISIBLE_STRING	Visible string (1 Octet per character)	8*n	
OCTET_STRING	Sequence of octets in ASCII format	8*(n+1)	
UNICODE_STRING	Sequence of UNICODE characters in UTF-16 format.	16*(n+1)	

Table 24: List of supported data types for EtherCAT variables

7.5 List of EtherCAT Items

List of EtherCAT Slave Registers

AL Status
EEPROM Data
Configured Station Address
AL Control
EEPROM Configuration
EEPROM Control/Status
EEPROM Address
SyncManager0
SyncManager1
Cyclic Unit Control
Activation
Register 0x0132
Register 0x0133
AL Status Code
FMMU0 ... FMMU15
SyncManager2
SyncManager3
SyncManager4
SyncManager5
StartTime Cyclic Operation / Next Sync0 Pulse
StartTime Cyclic Operation / Next Sync0 Pulse (Upper 32 Bits)
SYNC0 Cycle Time
SYNC1 Cycle Time
Latch0 Control
Latch1 Control
System Time

Table 25: Liste der EtherCAT Slave Register

Whether these items can be displayed in netANALYZER Scope or not, depends on whether the EtherCAT Master reads out this information via the network.

8 Analyzing PROFINET frames

This chapter describes PROFINET specific aspects.

8.1 List of supported data types for PROFINET variables

The configuration of netANALYZER Scope for PROFINET is done using GSDML files.

The following data types are supported in variables and constants of PROFINET devices (Controller and Device).

Data type name	Description	Bit length	Value range
BOOLEAN	'0': FALSE '1': TRUE	1	0 ... 1 (FALSE, TRUE)
Integer8	Short integer	8	-128 ... 127
Integer16	Integer	16	-32768 ... 32767
Integer32	Double integer	32	$-2^{31} \dots +2^{31}-1$
Integer64	Long integer	64	
Unsigned8	Unsigned short integer	8	0 ... 255
Unsigned16	Unsigned integer/Word	16	0 ... 65535
Unsigned32	Unsigned double integer	32	0 ... $+2^{32}-1$
Unsigned64	Unsigned long integer	64	0 ... $+2^{64}-1$
Float32	Floating point	32	
Float64	Long Float	64	
VisibleString	Visible string (1 Octet per character)	8*n	
OctetString	Sequence of octets in ASCII format	8*(n+1)	
UnicodeString	Sequence of UNICODE characters in UTF-16 format.	16*(n+1)	

Table 26: Supported PROFINET Data Types

8.2 Start-up of PROFINET communication

Some information relevant to netANALYZER Scope unfortunately is not contained in the GSDML files for PROFINET. netANALYZER Scope must acquire this information during the start-up phase of the PROFINET communication between PROFINET IO Controller and Devices.

Therefore it is crucial, that netANALYZER Scope can supervise the entire start-up phase of the PROFINET communication. Afterwards netANALYZER Scope will be able to identify and to list the Master- and Slave devices within the network.



Note:

If the data acquisition during the start-up phase of the PROFINET communication cannot be performed successfully, some or even all devices will then be missing in the Item View (see section *Working with the item list view* [▶ page 91]). The missing information can be added manually at any time, if necessary.

In order to do so, it is necessary to create a connection (see section *Side menu* [▶ page 24]). This must be done before the PROFINET communication (Creation of a PROFINET connection, request and response) starts.

After successful build-up of the connection, netANALYZER Scope waits for the connect request and connect response of the PROFINET connection. At test assemblies, you can cause a connect request by removing the cable and connecting it again. However, at running facilities, where this possibility is not available due to disturbance of the process, the configuration can be accomplished manually. If this occurs, within some seconds the devices of the PROFINET network will be identified one after the other and displayed in the item view including their associated modules and submodules.

At connection establishment there is also the possibility to reuse the formerly used configuration. If you intend this, you have to answer the dialog with “No”.

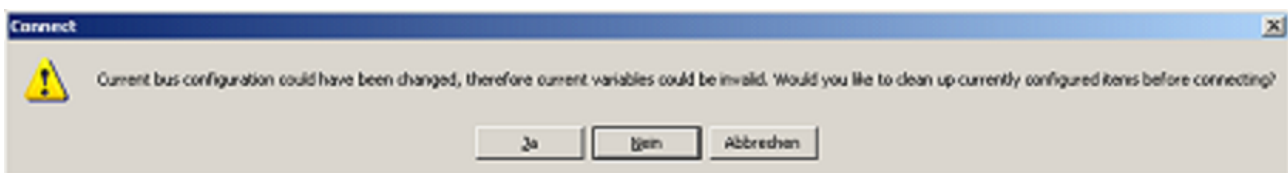

Figure 52: Keep current bus configuration

8.3 Communication events

The following communication events can be detected and used as trigger in PROFINET projects within netANALYZER Scope.

DCP Events

Event name	Description
DCP IDENT REQUEST	A DCP Ident Request frame has been sent.
DCP IDENT OK	A DCP Ident OK frame has been sent (an answer to "DCP IDENT REQUEST")
DCP HELLO REQUEST	A DCP Hello Request frame has been sent (e.g. in Fast Start Up)

Table 27: DCP Events

DCE-RPC Events

Event name	Description
DCERPC CONNECT REQUEST	A DCERPC Connect Request frame has been sent.
DCERPC CONNECT RESPONSE OK	A DCERPC Connect Response frame has been sent with ok (answer to "DCERPC CONNECT REQUEST").
DCERPC CONNECT RESPONSE ERR	A DCERPC Connect Response frame has been sent with error (answer to "DCERPC CONNECT REQUEST").
DCERPC CONNECT RESPONSE WITH DIFF BLOCK	A DCERPC Connect Response frame has been sent with ModuleDiffBlock (answer to "DCERPC CONNECT REQUEST").
DCERPC CONTROL REQUEST FROM PLC	A DCERPC Control Request frame from plc has been sent.
DCERPC CONTROL RESPONSE OK FROM DEV	A DCERPC Control Response frame from device has been sent with state <i>ok</i> (answer to "DCERPC CONTROL REQUEST FROM PLC").
DCERPC CONTROL RESPONSE ERROR FROM DEV	A DCERPC Control Response frame from device has been sent with state <i>error</i> (answer to "DCERPC CONTROL REQUEST FROM PLC").
DCERPC CONTROL RESPONSE WITH DIFF BLOCK FROM DEV	A DCERPC Control Response frame from device has been sent with ModuleDiffBlock (answer to "DCERPC CONTROL REQUEST FROM PLC").
DCERPC CONTROL REQUEST FROM DEV	A DCERPC Control Request frame from device has been sent.
DCERPC CONTROL REQUEST WITH DIFF BLOCK FROM DEV	A DCERPC Control Request frame from device has been sent with ModuleDiffBlock.
DCERPC CONTROL RESPONSE OK FROM PLC	A DCERPC Control Response frame from plc has been sent with state <i>ok</i> (answer to "DCERPC CONTROL REQUEST FROM DEV or DCERPC CONTROL REQUEST WITH DIFF BLOCK FROM DEV").
DCERPC CONTROL RESPONSE ERROR FROM PLC	A DCERPC Control Response frame from device has been sent with state <i>error</i> (answer to "DCERPC CONTROL REQUEST FROM DEV or DCERPC CONTROL REQUEST WITH DIFF BLOCK FROM DEV").

Table 28: DCE-RPC Events

Alarm Events

Event name	Description
ALARM NOTIFICATION HIGH FROM DEV	A high alarm notification frame from device has been sent. DATA-RTA
ALARM ACKNOWLEDGE HIGH FROM PLC	A high alarm acknowledge frame from plc has been sent (answer to "ALARM NOTIFICATION HIGH FROM DEV"). DATA-RTA
ALARM NOTIFICATION LOW FROM DEV	A low alarm notification frame from device has been sent. DATA-RTA
ALARM ACKNOWLEDGE LOW FROM PLC	A low alarm acknowledge frame from plc has been sent (answer to "ALARM NOTIFICATION LOW FROM DEV"). DATA-RTA
ALARM NOTIFICATION HIGH FROM PLC	A high alarm notification frame from plc has been sent. DATA-RTA
ALARM ACKNOWLEDGE HIGH FROM DEV	A high alarm acknowledge frame from device has been sent (answer to "ALARM NOTIFICATION HIGH FROM PLC"). DATA-RTA
ALARM NOTIFICATION LOW FROM PLC	A low alarm notification frame from plc has been sent. DATA-RTA
ALARM ACKNOWLEDGE LOW FROM DEV	A low alarm acknowledge frame from device has been sent (answer to "ALARM NOTIFICATION LOW FROM PLC"). DATA-RTA
ALARM HIGH FROM DEV	A high alarm frame from device has been sent. ERR-RTA
ALARM LOW FROM DEV	A high alarm frame from device has been sent. ERR-RTA
ALARM HIGH FROM PLC	A high alarm frame from plc has been sent. ERR-RTA
ALARM LOW FROM PLC	A low alarm frame from plc has been sent. ERR-RTA

Table 29: Alarm Events

Other Events

Event name	Description
UNEXPECTED CYCLE COUNTER	The value of cycle counter does not match the expected value (for example one or more cyclic frames were not transferred).

Table 30: Other Events

In order to trigger on any of these events, proceed as follows:

1. Define a constant of type `VISIBLE_STRING`. You may assign any name to it.
2. Select option `ASCII string` in column *Representation*.
3. For this constant, enter the string containing name of the event you want to use as triggering source in column *Value*.



Note:

See section *Working with constants* [▶ page 205].

Example

You want to trigger on the ALARM NOTIFICATION LOW FROM DEV event and your constant shall be named `Trigger_Event_PLC_Low_Alarm`.

In order to implement this example, define the constant like this:

Const	Name	Type	Representation	Value	
CONST0	Trigger_Event_PLC_Low_Alarm	VISIBLE_STRING	ASCII string	ALARM NOTIFICATION LOW FROM PLC	x
CONST1	const1	INTEGER32	Decimal	0	x
CONST2	...	INTEGER32	Decimal	0	x

Figure 53: Example : Triggering on PROFINET Communication Events

9 Analyzing EtherNet/IP frames

This chapter describes aspects of data acquisition from cyclic EtherNet/IP connections. Systems exclusively using acyclic communication such as the Rockwell MicroLogix PLCs are not supported by netANALYZER Scope.

9.1 List of supported data types for EtherNet/IP variables

The configuration of netANALYZER Scope for EtherNet/IP is done using Rockwell Studio5000 files (*.L5X files) and EDS files.

The following data types are supported in variables and constants of EtherNet/IP devices (Scanner and Adapter).

Name of data type (in CIP standard)	Name of data type (in GUI)	Description	Bit length	Range of values
BOOL	BOOLEAN	'0': FALSE '1': TRUE	1	0 ... 1 (FALSE, TRUE)
	BIT1		1	
	BIT2		2	
	BIT3		3	
	BIT4		4	
	BIT5		5	
	BIT6		6	
	BIT7		7	
	BIT8		8	
SINT	INTEGER8	Short integer	8	-128 ... 127
ITIME	INTEGER16	Integer	16	-32768 ... 32767
-	INTEGER24	Integer (24 bit)	24	
TIME, FTIME	INTEGER32	Double integer	32	$-2^{31} \dots +2^{31}-1$
-	INTEGER40	Integer (40 bit)	40	
-	INTEGER48	Integer (48 bit)	48	
-	INTEGER56	Integer (56 bit)	56	
LTIME	INTEGER64	Long integer	64	
BYTE	UNSIGNED8	Unsigned short integer	8	0 ... 255
DATE, WORD, ENGUNIT	UNSIGNED16	Unsigned integer/Word	16	0 ... 65535
-	UNSIGNED24	Unsigned integer (24 bit)	24	
TIME_OF_DAY, TOD, DWORD	UNSIGNED32	Unsigned double integer	32	0 ... $+2^{32}-1$
-	UNSIGNED40	Unsigned integer (40 bit)	40	
DATE_AND_TIME	UNSIGNED48	Unsigned integer (48 bit)	48	
-	UNSIGNED56	Unsigned integer (56 bit)	56	
STIME, LWORD	UNSIGNED64	Unsigned long integer	64	0 ... $+2^{64}-1$
REAL	REAL32	Floating point	32	
LREAL	REAL64	Long Float	64	
-	VISIBLE_STRING	Visible string(1 Octet per character)	8*n	
All other types	OCTET_STRING	Sequence of octets in ASCII format, including delimiter	8*(n+1)	
-	UNICODE_STRING	Sequence of UNICODE characters in UTF-16 format, including delimiter	16*(n+1)	

Table 31: Supported data types for EtherNet/IP variables and constants

9.2 Start-up of EtherNet/IP communication

At EtherNet/IP some relevant information for netANALYZER Scope is not contained within Rockwell Studio5000 files (*.L5X files) and the EDS files. netANALYZER Scope must obtain this information by listening to the EtherNet/IP-communication between Scanner und Adapters during its start-up phase.

Therefore it is important, that netANALYZER Scope can monitor the complete start-up phase of the EtherNet/IP communication. Having finished this, netANALYZER Scope is able to identify and list the EtherNet/IP Scanner and Adapter devices within the network.



Note:

If the data acquisition during the start-up phase of the EtherNet/IP communication did not succeed, then some or even all devices including their modules and variables will be missing within the Item View (see section *Working with the item list view* [▶ page 91]). The missing information can always be supplied manually, if required (see *Solution strategies for the manual configuration in special cases* [▶ page 86]).

In order to supervise the start-up of the EtherNet/IP communication it is necessary to establish a connection between netANALYZER Scope and the netANALYZER device. This is accomplished via the entry **Connect** in *Side menu* [▶ page 24] and must already be done before the communication starts up (Establishment of EtherNet/IP connection, request and response)).

If a connection has been accomplished, netANALYZER Scopewaits for the establishment of the EtherNet/IP connection. At test assemblies, you can force a connect request by removing the cable and then connecting it again. However, at running plants this possibility is not available as this would disturb the oricess. In this case, the configuration can be done manually.

If the connection is successfully established, within some seconds the devices of the EtherNet/IP network will be identified one after the other and displayed in the item view including their associated modules and submodules.

For the case of an already stored configuration there is also the possibility to reuse the old configuration of the variables. If this is intended, you have to answer the dialog with "No". Für den Fall, dass bereits eine Konfiguration gespeichert ist, gibt es bei der Herstellung der Verbindung auch die Möglichkeit, die alte Konfiguration der Variablen wiederzuverwenden. Wenn Sie dies wollen, müssen Sie die dann erscheinende Sicherheitsabfrage mit „Nein“ beantworten.

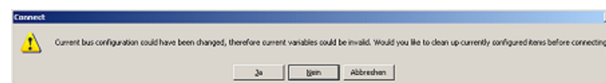

Figure 54: Keep current bus configuration

However, if you respond with "Yes", the currently configured variables are deleted. Then a new supervision of network start-up is required for automatically setting up the the configuration.

9.3 Automatic configuration

Usually, the configuration is performed automatically. However, a fully automatic configuration requires the fulfillment of the following conditions:

1. Listening to the start-up phase of the EtherNet/IP network communication could be accomplished successfully (see *Start-up of EtherNet/IP communication* [▶ page 84]).
2. Presence of a suitable Rockwell Studio 5000 project (*.L5X file)
3. Presence of a suitable device description files (*.EDS files) for all affected devices (EtherNet/IP Adapter) within the EtherNet/IP network.

If one or more of these preconditions could be fulfilled only partially or not even at all, the according tags have to be added to the configuration manually.

9.4 Solution strategies for the manual configuration in special cases

This section describes in detail, how in special cases you can configure netANALYZER Scope manually when the prerequisites of automatic configuration are not fulfilled and provides appropriate solution strategies for these cases.

9.4.1 Special cases

The following special cases require a manual configuration of netANALYZER Scope:

1. Missing project file
2. Missing device description file(s) (*.EDS files)
3. Monitoring of network start-up failed
4. Usage of rack-optimized data types in Rockwell Studio 5000

9.4.1.1 Missing project file

If for your EtherNet/IP network, there is no appropriate Rockwell Studio 5000 project present as *.L5X file, neither the information about the configured variables nor the optional names of controllers, devices and modules can be detected.

Due to the missing Rockwell Studio5000 project, additional manual configuration steps are required within the applicable wizards.

- Within the variable assistant, all variables beside the raw input and raw output data must completely be configured manually. Take the necessary information from your system's project files or the configuration of your Ethernet/IP Scanner and if required, Ethernet/IP Adapter. To do so, see description in *Configuring variables with failed acquisition afterwards* [▶ page 87].

For instance, this applies in case you use a controller not manufactured by Rockwell.

9.4.1.2 Missing device description file(s) (*.EDS files)

If not all necessary device description files are present, for affected devices or modules all variables beside the raw input data and raw output data must be specified manually afterwards within the variable assistant. Take all required information from the project file of your system or the configuration of your EtherNet/IP Scanner and if necessary, the adapters. To do so, follow the description in *Configuring variables with failed acquisition afterwards* [▶ page 87].

9.4.1.3 Monitoring of network start-up failed

If the start-up of the network could not be monitored during automatic configuration, a fully manual configuration of the controller (see *Controller wizard* [▶ page 131] and all devices (see *Device wizard* [▶ page 132]) as well as the modules (see *Module Wizard* [▶ page 136] and variables (see *Variable Wizard* [▶ page 140]) of the affected devices, which could not be monitored during start-up.

Follow the description in section *Description of manual configuration when acquisition during network start-up fails* [▶ page 87]. Take care of the table within this section. In any case, at least specify the parameters listed there in fat print.

9.4.1.4 Usage of rack-optimized data types in Rockwell Studio 5000

If in Studio 5000 you define module definitions using the connection types "**Rack Optimization**", "**Enhanced Rack Optimization**" or "**Listen only - Rack Optimization**", these definitions can prohibit the automatic detection of the configuration. In this case, follow the hints given in section *Handling data of type "Rack-optimized"* [▶ page 88].

9.4.2 Solution strategies

9.4.2.1 Description of manual configuration when acquisition during network start-up fails

If the acquisition of the configuration parameters during network start-up was not successful, you have to specify all values manually within the wizards except those which have been signified as optional.

9.4.2.2 Configuring variables with failed acquisition afterwards

All variables beside the *raw input data* and the *raw output data* must be manually reconfigured using the context menu entry "Add variable" (see *Add an item* [▶ page 128]). This must be done separately for each single variable using the *variable wizard* [▶ page 140]. Take the relevant information from the commissioning of your system as well as the configuration of your Ethernet/IP scanner and, if necessary, the adapters.

9.4.2.3 Configuring names with failed acquisition afterwards

If no *.L5X file can be evaluated, the (optional) name fields within the wizards remain empty (beside the fields in the variable wizard for raw input data and raw output data). Although this step is not really necessary for the automatic configuration, these name fields should be filled for better identification.

- The field **Name** within the controller wizard containing the name of the controller.
- The field **Name** within the device wizard containing the name of the device.
- The field **Name** within the device wizard containing the name of the device.

9.4.2.4 Handling data of type "Rack-optimized"

Using connections of the following types within Studio 5000 projects may adversely affect the automatic configuration of netANALYZER Scope:

- **"Rack Optimization"**
- **"Enhanced Rack Optimization"**
- **"Listen only - Rack Optimization "**

For optimization purposes, these types send information to the head stations of the respective modules instead of the modules themselves. The head station provides central administration. This causes the modules not to be detected by netANALYZER Scope. In this case, the respective data have to be configured manually, if necessary by taking into account the information within the raw input and output data. You can create new variables for the single bits using the copy function.

Connections of these types do not cause any problems:

- **None**
- **Data**
- **Listen only**

9.4.2.5 Manual configuration of routed EtherNet/IP networks (CIP Routing)

The integrated detection mechanisms allow an automatic configuration of routed EtherNet/IP networks (CIP Routing). Usually, *no manual configuration* of routed EtherNet/IP networks should be *necessary*.

If this is nevertheless intended, the following specifications might be helpful:

- The IP address of the router and the specifications concerning port segments must be entered manually.
- You can take both from a Wireshark® trace of your EtherNet/IP network.
- The port segments can be found in Wireshark® below Port segments, by clicking at the respective port in Wireshark® you can determine which port segment belongs to which port. This port segment is marked by color in Wireshark®.

10 Using views for analysis

All windows of the netANALYZER Scope have a bar with up to 5 icons. When pointing with the mouse pointer to one of the icons at the right side of the window bar, the respective icon is highlighted in red as shown below. The icons in the upper right corner have the following meaning:







Icon	Action	Description
	Minimize	Minimizes the window
	Maximize	Maximizes the window
	Position window	Allows positioning a new window to left, right, upper or lower edge (Docking).
	Undock	Undo docking
	Close	Closes the current window
	Back	Back to the old size

Table 32: Icons within the icon bar

10.1 Working with the item list view

An item list offers you all data items which you might like to capture such as the values of variables and registers of the slaves within the network.

10.1.1 Open a new item list view

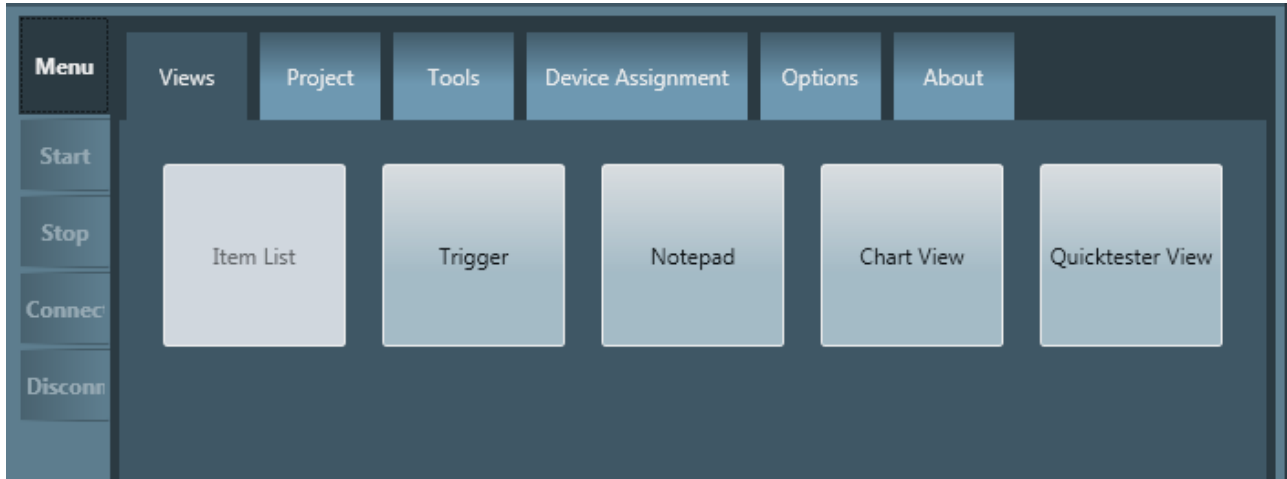

Figure 55: Menu Pane Views

1. In order to open an item list window:
 - Choose the menu option *Item list*.
 - ⇒ An item list window is displayed within the netANALYZER Scope window.
 - ⇒ Now, the item list window should look like this:

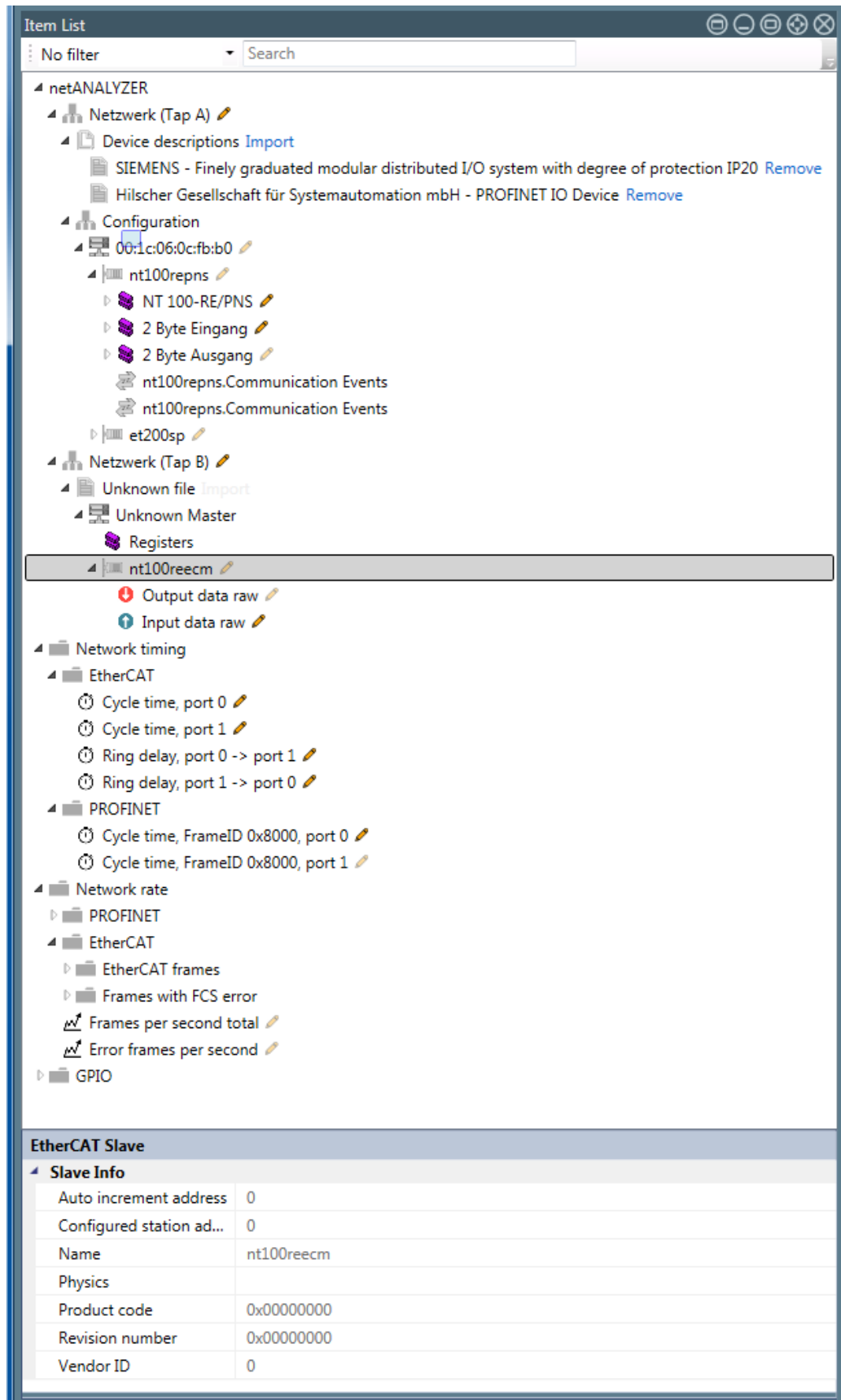

Figure 56: Register card EtherCAT configuration

The bar at the upper edge of the window should now look similar as in the following figure:



or



This bar offers access to various filtering possibilities.

On the left side, there is a selection list allowing to choose between three options:

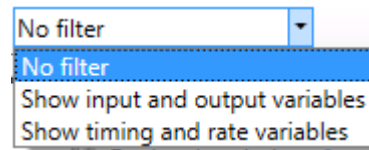



Figure 57: Selection list for filtering (expanded)

Option	Meaning
No filter	No filtering occurs. All items are displayed without restriction.
Show input and output variables	Only input and output signals are displayed.
Show timing and rate variables	Only timing and network rate signals are displayed.

Table 33: Display options (filtering)

There is also the possibility to search an element of a list by specifying a search string contained in the element's name.

- In order to search for elements containing a specific sequence of characters:

- Click at symbol  at the right end of the bar!
- An input field for specifying the search string opens.
- Enter the search string there.
- ⇒ The display is restricted to the matching items.

10.1.2 General dialogs of the context menu

In this context, the following elements of the structure tree are considered as items

- Controller
- Devices
- Modules
- Submodules
- Variables

The context menu (of an item) is invoked by clicking at any item in the tree with the right mouse button. Depending on the chosen item, various functions can be invoked.

In the following all these functions are described each with the name of the corresponding context menu entry invoking the specific function and the item on which the function can be invoked.

The following functions of the context menu are available in EtherCAT trees:

10.1.2.1 Edit network

Corresponding context menu entry: *Edit network*

Item: *Network*

For each TAP (TAP A or TAP B) of the netANALYZER, the network configuration data have to be specified, for instance, whether the network to be analyzed is an EtherCAT, an EtherNet/IP or a PROFINET network.

When defining a new network, the required data for it have to be added via the **Network wizard**. A new network can added to the item list at the two Network items (TAP A or TAP B) which are located on level 2 of the structure tree, i.e. directly below the top level item.

Then, the context menu looks like this:

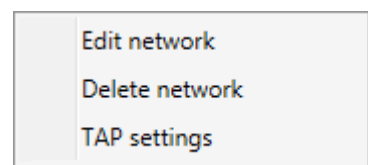

Figure 58: *Edit network*

1. In order to invoke the **Network wizard**:

- Select the context menu **Edit Network** or click at the pencil symbol right next off he **network** entry.
- The first page of the **Network wizard** appears:

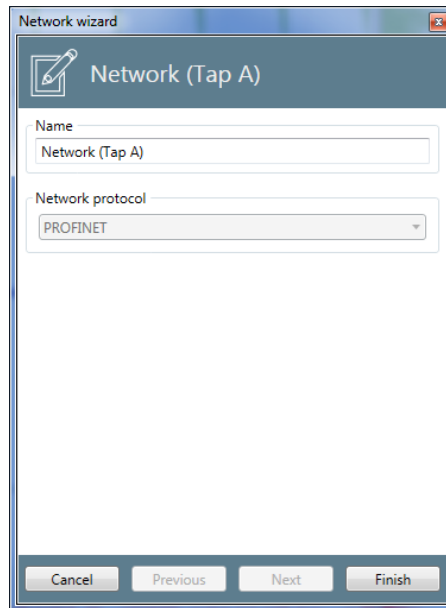
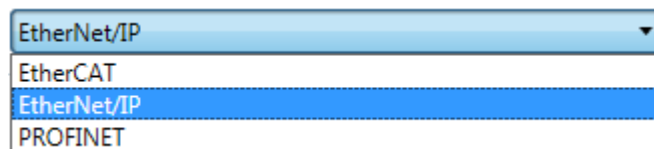

Figure 59: First page of the Network wizard

- Under *Name*, specify the name here under which to identify the network in future.
- Under *Network protocol*, select the protocol used in the network to be analyzed which is connected to the chosen TAP, either EtherCAT or PROFINET.



- If you selected option *EtherCAT*, then click at button *Next*.
- The second page of the **Network wizard** appears:

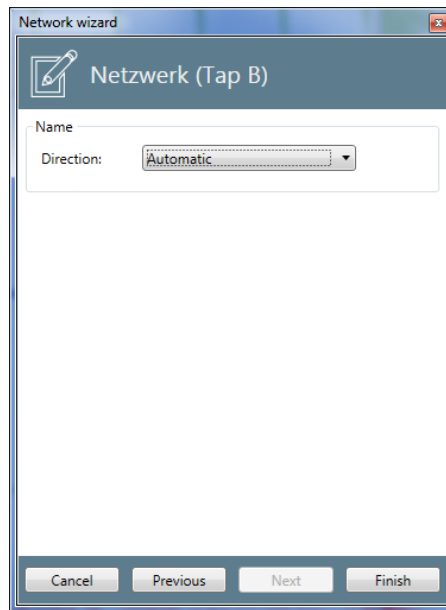
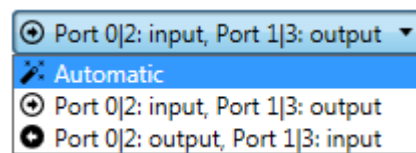

Figure 60: Second page of the Network wizard

- Select the data direction of the EtherCAT network at the selection list Direction.



You may choose between these three options.

- *Automatic*
- *Port 0|2: input, Port 1|3: output*
- *Port 0|2: output, Port 1|3: input*

The automatic detection of the data direction for EtherCAT is accomplished via the *processed* flag in the EtherCAT MAC address. If no automatic detection of the data direction is possible, because the flag has not been set expectedly, the data direction must be adjusted manually. You can detect this situation during the analysis of a recording by the message Detection of the data direction not possible within the status bar of the main window.



Note:

For details, see section *Chart data are displayed incorrectly for EtherCAT* [▶ page 254].

- Click at **Finish** to complete the **Network wizard**.
- ⇒ This closes the **Network wizard** and stores the network-related data.
- If there was already a network configuration present at the chosen TAP, the following safety message box will appear informing you that the old data will be overwritten if you continue.

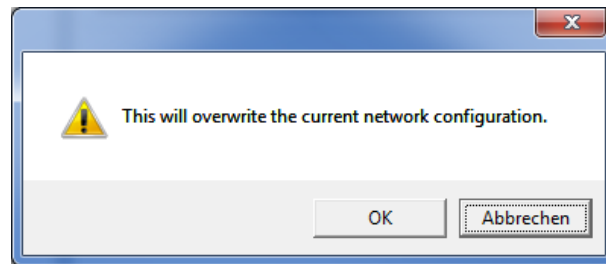

Figure 61: Safety message "Overwrite network configuration"

If you want to save the new configuration by overwriting the old, click *Ok* and the new configuration is saved, otherwise click *Cancel*.

10.1.2.2 Delete network

Corresponding context menu entry: *Delete network*

Item: *Network*

The context menu entry allows to delete complete network definitions

1. In order to delete a network completely:
 - Select context menu entry **Delete network**
 - ⇒ A safety message indicating that all corresponding variables of the network will be deleted from the Chart View window.

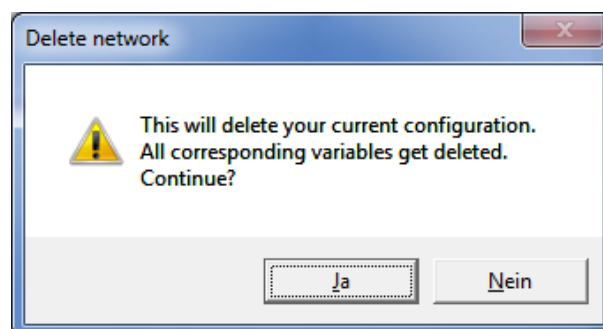

Figure 62: Safety message on Delete Network

- ⇒ If you click at *Yes*, the complete network will be removed from the structure tree. All definitions in the Chart View window which relate to items (such as variables) defined by the network, will also be deleted!
- ⇒ If you click at *No*, nothing will happen.

10.1.2.3 TAP Settings

Corresponding context menu entry: *TAP Settings*

Item: *EtherCAT network*

This context menu entry allows to define the position of the netANALYZER within the EtherCAT network. By a change of the position the expected working counters (WKC) of the EtherCAT datagramms are recalculated. After importing the ENI file always an installation position immediately behind the EtherCAT Master is assumed.

However, in PROFINET networks, this is not necessary.

1. In order to specify the position of the netANALYZER within the EtherCAT network:
 - Select context menu entry **TAP Settings**
 - The following dialog appears:

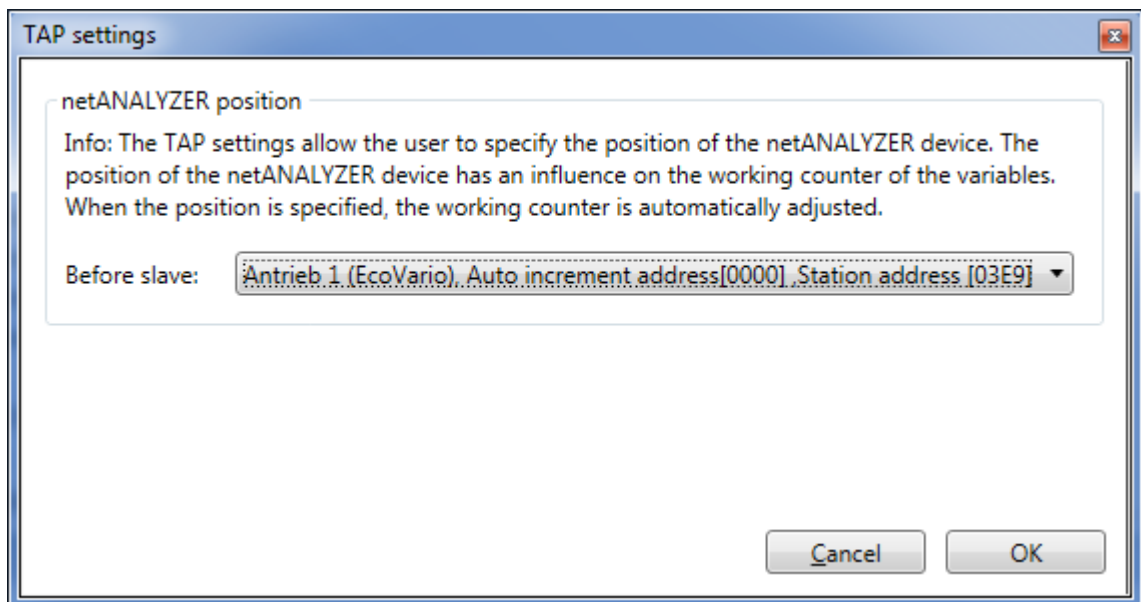

Figure 63: Dialog "TAP settings"

- The dialog offers a list of locations within the (EtherCAT) network, where the netANALYZER could be located.
- Choose the correct location of the netANALYZER within your EtherCAT network. Specify the slave before which the netANALYZER is currently located

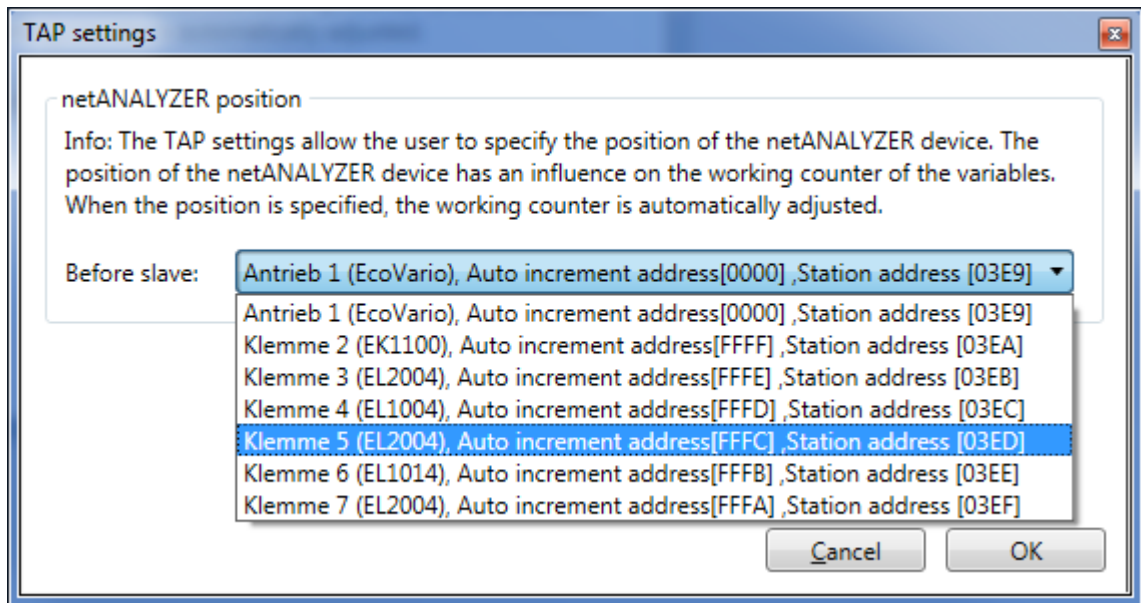

Figure 64: Selection list "Before slave"

- ⇒ If you click at *Ok*, the working-counters of all variables are recalculated based on the selected position.
- ⇒ If you click at *Cancel*, nothing will happen.



Note:

Failure of the automatic detection of the data direction may happen, when changing the position of the netANALYZER TAPs. In this case, the data direction must be adjusted manually. This is done according to the last step in the description in section *Edit network* [▶ page 94] prior to closing the dialog.



Note:

Variables of slaves, which are located in front of the selected position of the netANALYZER, are automatically marked in red within the item list, if no valid values for these variables can be read anymore where applicable (depending on the EtherCAT network commissioning). For instance, because the variable value originally sent by the master has already been changed by upstream slaves.

10.1.2.4 Import

Corresponding context menu entry: *Import*

Item: *Network*

For existing EtherCAT, Ethernet/IP and PROFINET networks often already electronic device description files exist.

netANALYZER Scope allows you to read these files in order to avoid unnecessary remodeling of the existing network. netANALYZER Scope can read and analyze the following types of files:

System	Required file type	File extension
EtherCAT	Device description file (EtherCAT Network Information file)	(* .ENI)
PROFINET	Device description file (GSDML file)	(* .xml)
Ethernet/IP	Device description file (EDS file)	(* .eds)
Ethernet/IP	Rockwell Studio 5000 project file (* .L5X)	(* .L5X)

Table 34: Network description files for use with netANALYZER Scope:

A description file for a network can be added to the structure tree below the *Network* item on level 3.

- Select context menu entry **Import**. The context menu will then look like this:

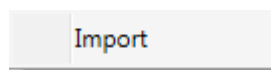

- The import dialog for the selection of a *.ENI, *.xml, *.eds or *.L5X file appears depending on the selected network. erscheint je nach Art des gewählten Netzwerks. In any case, select the required network description file.
- Click at the *Open* button.
- ⇒ The structure definitions of the EtherCAT, Ethernet/IP or PROFINET network are imported and the structure tree within the item view is updated accordingly.

10.1.3 Dialogs of the context menu for EtherCAT

The context menu (of an item) is invoked by clicking at any item in the tree with the right mouse button. Depending on the chosen item, various functions can be invoked.

In the following all these functions are described each with the name of the corresponding context menu entry invoking the specific function and the item on which the function can be invoked.

The following functions of the context menu are available in EtherCAT trees:

10.1.3.1 Adding a device

Context menu: *Add Device*

Item: *Master*

For each EtherCAT Slave device, the EtherCAT-specific configuration data have to be known. These are usually taken from a configuration file (the *.ENI file). When defining a new Device, the required data for it have to be added via the dialog **Add Device**.

1. For entering the configuration data manually, proceed as follows:
 - Right-click the master in the item list, the slave should be inserted.
 - the context menu is displayed:

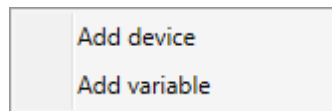

Figure 65: Context menu of the EtherCAT Master

- Select the entry **Add Device**.
- The first page of the dialog **Add Slave** opens:

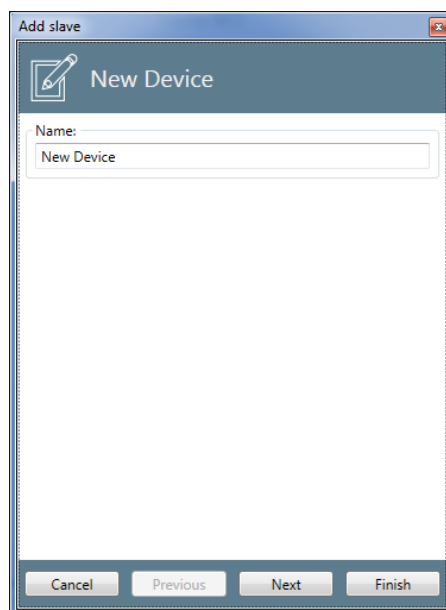

Figure 66: Dialog Add Slave - first page

- Under *Name*, specify the name under which to identify the EtherCAT Slave device in future here.
- Click *Next*.

➤ The second page of the dialog **Add Slave** opens:

Figure 67: Dialog Add Slave - second page

In the dialog **Add Slave**, the following configuration is done:

Configured Station address

This address is used in the node addressing method. The value can be specified in decimal format in the left input field or in hexadecimal format in the right input field. The permitted range of values for the Configured Station Address extends from 0 to 65535 (Hex.: 0 to 0xFFFF.)



Note:

For more information on the node addressing method, see EtherCAT Specification Part 3 Section 4.8.3.3 Node Addressing.

Auto increment address

This address is used in the position addressing method. The value can be specified in decimal format in the left input field or in hexadecimal format in the right input field. The permitted range of values for the Configured Station Address extends from 0 to 65535 (Hex.: 0 to 0xFFFF).



Note:

For more information on the position addressing method, see EtherCAT Specification Part 3 Section 4.8.3.2 Position Addressing.

Physics

This parameter specifies the port type of the connection on the physical layer (i.e. on layer 1 of the OSI/ISO layer model of networking).

Up to four capital letters taken from the set {B, F, K, Y} characterizes the port type of port 0 up to port 3 in this order.

The meaning of these letters is defined as follows:

Letter	Corresponding port type
Y	Ethernet Copper (100BaseTX)
F	Ethernet Fiber-optic (100BaseFX)
K	E-Bus Backplane
B	Reserved
Space	Not used

Table 35: Coding of parameter "Physics"

Vendor ID

This parameter represents the Vendor ID within the Identity Object of the EtherCAT Object Dictionary (Index 0x1018, Subindex 1).

The value is entered decimally in the left input field or hexadecimally in the right input field. The allowed range of values for Vendor ID extends from 0 to 0x7FFFFFFF (0 up to 2.147.483.647).

Product code

This parameter represents the product code in the Identity Object within the EtherCAT Object Dictionary (Index 0x1018, Subindex 2).

The value is entered decimally in the left input field or hexadecimally in the right input field. The allowed range of values for the Product Code extends from 0 up to 0xFFFFFFFF (corresponding to 0 up to 4294967295).

Revision number

This parameter represents the Revision number in the Identity Object within the EtherCAT Object Dictionary (Index 0x1018, Subindex 3).

The value is entered decimally in the left input field or hexadecimally in the right input field. The allowed range of values for the Product Code extends from 0 up to 0xFFFFFFFF (corresponding to 0 up to 4294967295).



Note:

For more information concerning VendorID, Product Code and Revision Number, see EtherCAT Specification Part 6 Section 5.6.7.4.6 *Identity Object*.

10.1.3.2 Context menu dialog "Adding a variable"

Corresponding context menu dialog *Add Variable*

Item: *Master* or *Slave*

A variable can be added to the item list below the EtherCAT Slave or the EtherCAT Master.

Below the EtherCAT Master, the context menu looks like this:

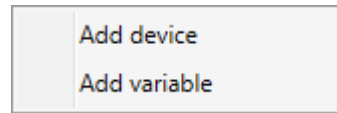

Figure 68: Context menu for EtherCAT Master

Below the EtherCAT Slave, the context menu looks like this:

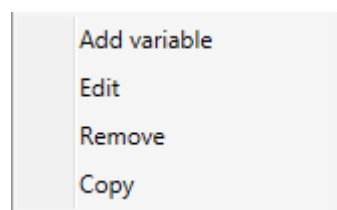

Figure 69: Context menu for EtherCAT Slave

1. In both cases, a variable is added to the item list as follows:
 - Right-click at the master or slave under which the variable shall be added.
 - The context menu appears, see figures above.
 - Click to the respective context menu entry *Add variable*.
 - The first page of dialog *Add variable* is opened. It looks as follows:

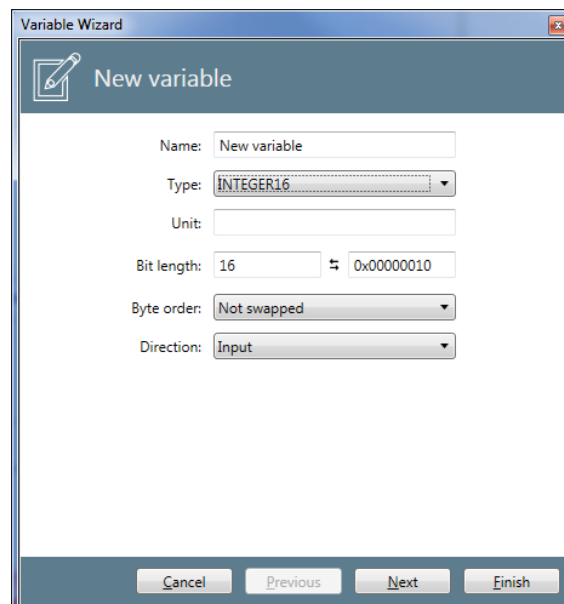

Figure 70: Dialog Add Variable - first page

- Under *Name* specify the name which shall identify the EtherCAT Slave device in future.

The fields within the dialog *Add variable* have the following meaning:

Name

The name of the variable

The name identifying the variable to be defined here. As long as no input into this mandatory field occurs, the input field has a red frame.

This name is also displayed in the variable area of the variable to be defined within the block Variable Info, see section „Variable area“.

Type

The datatype of the variable You can find a list of suitable datatypes in *List of supported data types for variables* [► page 76].

Unit

The corresponding unit of the variable

Bit length

The length of the data type specified under Type given as number of bits.

Here, the bit length can be set to values from 1 up to the maximum bit width of the selected datatype. If less bits are chosen than the used data types has, the remaining bits are filled with 0 at unsigned datatypes. Signed datatypes the sign is extended onto the remaining bits.

Byte order

Here it can be specified whether the order of bytes in a data word is swapped (*Swapped*) or not (*Not swapped*).

Direction

This selection list allows you to select the signal direction to be applied.

Here, “input” means data transfer from the EtherCAT Slaves to the EtherCAT Master, while “output” means data transfer from the EtherCAT Master to the EtherCAT Slaves

See also section *Definition of signal directions* [► page 74].

However, the available choices depend on the kind of command selected at selection list Command which has been described just above.

Kind of command	Affected EtherCAT command codes	Options to select
Read commands	APRD, FPRD, BRD and LRD	<i>input</i> only
Write commands	APWR, FPWR, BWR and LWR	<i>output</i> only
Read/write commands	APRW, ARMW, FPRW, FRMW, BRW and LRW	<i>Input and output</i> are selectable

Table 36: Possible selections depending on mode of operation

➤ Click at *Next*.

➤ The second page of the dialog *Add variable* appears:

Figure 71: Dialog *Add Variable* - second page

The fields in the dialog *Add variable* have the following meaning:

Command name

Freely selectable command name (editable, is displayed in selection list *Selected command* along with the command code

Bit offset in command

This data field contains the offset of the variable to be defined relative to the beginning of the Data field in the EtherCAT datagram. It is counted as number of bits from the position of the first bit of the first variable in the data field of the EtherCAT datagram. If the variable to be defined is the first one within the data field of the EtherCAT datagram, then this value equals 0.

If an invalid value is entered, this is emphasized by a red frame around the field *Bit offset*. However, it does not make sense to specify values exceeding 11888 (equivalent to $8 \cdot 1486$).

Command

If a single variable value should be transferred via EtherCAT by multiple commands, more commands can be added in the command list as necessary.

For an overview on the applicable EtherCAT command codes, see section *List of EtherCAT commands* [► page 75] or the EtherCAT specification (reference [2]).

Command byte data length

This data field contains the length of the EtherCAT datagram specified as number of bytes of the datagram.

This corresponds to the EtherCAT command specified in field *Data Length* in the EtherCAT datagram, see *EtherCAT datagram structure* [► page 73].

The allowed range of values extends from 0 to 1486. If an invalid value is entered, this is emphasized by a red frame around the field Data length of the command. However, it does not make much sense to specify larger values than 1486 here.

Working counter

This field contains the expected value of the working counter (WKC).

The WKC value is used for the determination of the validity status of a variable value. For a WKC value unequal to the value specified here, the status is automatically set to invalid.

This corresponds to the EtherCAT command specified in the field *Expected Working Counter* within the EtherCAT datagram. See *EtherCAT datagram structure* [► page 73].

The WKC value is automatically adjusted if another netANALYZER installation location is chosen.

The allowed range of values extends from 0 to 4294967295.

Command address

Depending on the choice in the selection list **Command** different kinds of addresses can be specified here.

- If a command with autoincrement addressing such as APRD, APWR or APRW has been chosen there, the autoincrement address and an offset can be specified here. The input field is denominated as *autoincrement address*. The values of the autoincrement address and the offset are both specified as hexadecimal value. The allowed range of values extends from 0 to 0xFFFF.
- If a command with addressing via the configured station address such as CPRD, CPWR or CPRW has been chosen there, the configured station address and an offset can be specified here. The input field is designated as *configured station address*. The values of the configured station address and the offset are both specified as hexadecimal value. The allowed range of values extends from 0 to 0xFFFF.
- If a command with broadcast addressing such as BRD, BWR or BRW has been chosen there, the broadcast address and an offset can be specified here. The input field is designated as *broadcast address*. The values of the broadcast address and the offset are both specified as hexadecimal value. The allowed range of values extends from 0 to 0xFFFF.
- If a command with logical addressing such as LRD, LWR or LRW has been chosen there, the logical address can be specified here. The input field is designated as *logical address*. The values of the logical address is specified as hexadecimal value. The allowed range of values extends from 0 to 0xFFFFFFFF.

This field corresponds to the EtherCAT command specified in the field "Command address" within the EtherCAT datagram. See *EtherCAT datagram structure* [▶ page 73].

➤ Click at **Next..**

⇒ The third page of the **Variable Wizard** dialog is opened.

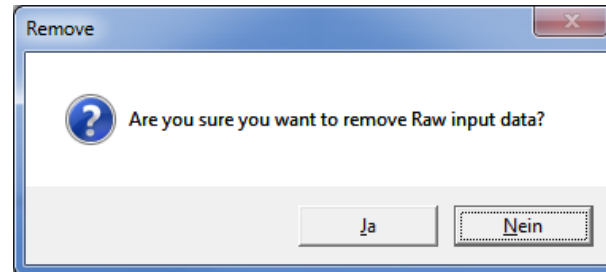

Figure 72: Dialog Variable Wizard - second page (Normalization)

On this page you can specify how to normalize the measured data (if this is desired).

The fields in dialog **Variable Wizard** have the following meaning:

Field name	Meaning
Type	The normalization type. If the option None is chosen, the values Scale and Offset are set to 0 and thus no normalization of the measured data takes place. Otherwise, it is possible to perform a customdefined normalization based on the fields Factor and Offset. During this normalization, the initial value is first multiplied with the factor Scale and then the Offset is added to the product. Scale Specify the factor Scale for the user-defined normalization
Scale	Factor Scale for user-defined normalization.
Offset	Offset for user-defined normalization.

Table 37: Dialog Variable Wizard - second page

➤ Click at **Finish** in order to display the configured variable in your project.

⇒ The entered configuration data for the variable are stored within the project.

10.1.3.3 Context menu dialog "Variable wizard"

Corresponding context menu entry *Edit*

Item: *Slave*

1. A variable in the item list below the EtherCAT Slave can be edited.
 - Rightclick at the master or slave under which the variable shall be added.

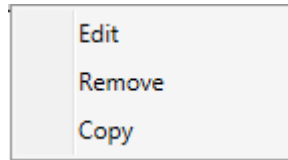

➤ The context menu is opened. It looks like this:

- Click at the entry *Edit* in the context menu.

The first page of the *Variable Wizard* dialog is opened. It looks like:

10.1.3.4 Remove

Entsprechender Kontextmenü-Eintrag: *Remove*

Item: *Slave*

Dieser Kontextmenü-Eintrag erlaubt es, ein Item aus der Item Liste zu entfernen.



Note:

Items können nur entfernt werden, wenn diese in keiner anderen Ansicht (Chart View

Wenn Sie diesen Eintrag anklicken, erscheint eine Sicherheitsabfrage, ob Sie das betreffende Item wirklich löschen wollen.

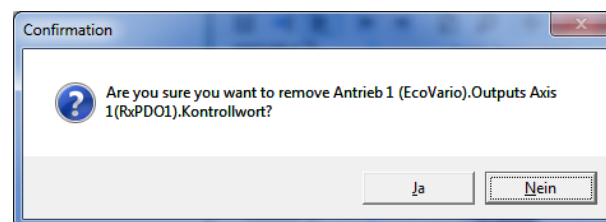

Figure 73: Sicherheitsabfrage bei Kontextmenü-Eintrag Remove

Zwei Möglichkeiten stehen zur Verfügung:

- Wenn Sie mit *Ja* antworten, wird das Item sofort gelöscht.
- Wenn Sie mit *Nein* antworten, geschieht nichts.

10.1.4 Dialogs of the context menu for PROFINET

The context menu (of an item) is invoked by clicking at any item in the tree with the right mouse button. Depending on the chosen item, various functions can be invoked.

In the following all these functions are described each with the name of the corresponding context menu entry invoking the specific function and the item on which the function can be invoked.

The following functions of the context menu are available in PROFINET trees.

10.1.4.1 Add an item

Item	Superordinate item	Appropriate context menu	Name of context menu
Controller	Configuration		Add Controller
Device	Controller		Add/ edit/ remove/ copy device
Module	Device		Add/ edit/ remove/ copy module
Submodule	Module		Add/ edit/ remove/ copy submodule
Variable	Submodule		Add/ edit/ remove variables

Table 38: Items, superordinate items and appropriate context menus

Step-by-step instruction

In order to add a new item (i.e. <item> = *contoller*, *device*, *module*, *submodule* or *variable*):

- In order to add an item, click at the designated superordinate item within the item list using the **right** mouse button. The superordinate item is then located right above the item. Table *Items, superordinate items and appropriate context menus* [▶ page 110] indicates of which type the superordinate item should be.
- ⇒ The context menu appropriate to the item appears (see table *Items, superordinate items and appropriate context menus* [▶ page 110])
- Select context menu entry **Add <Item>**.
- ⇒ The **<Item> wizard** is displayed.

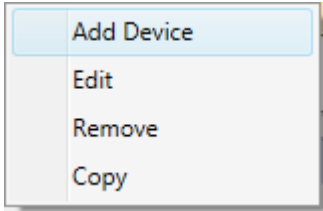
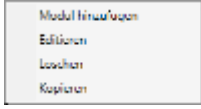
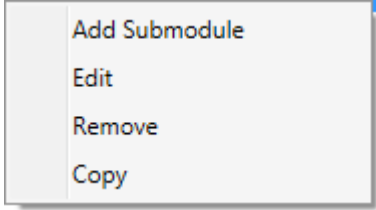
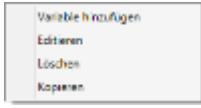
The further proceeding is explained within the sections describing the wizard:

Item/wizard	Section containing the description
Controller	<i>Controller assistant</i> [▶ page 115]
Device	<i>Device wizard</i> [▶ page 116]
Module	<i>The module wizard</i> [▶ page 119]
Submodule	<i>Submodule wizard</i> [▶ page 121]
Variable	<i>Variable wizard</i> [▶ page 125]

Table 39: Wizards

10.1.4.2 Edit an item

Item	Appropriate context menu	Name of context menu
Controller		Editing a controller
Device		Add/ edit/ remove/ copy module
Module		Add/ edit/ remove/ copy submodule
Submodule		Add/ edit/ remove/ copy variable
Variable		Edit/ remove/ export/ import/ copy

Table 40: Items and appropriate context menus

Step-by-step instructions

In order to add a new item (i.e. *controller*, *device*, *module*, *submodule* and *variable*)

- In order to add an item, click at the designated item within the item list using the **right** mouse button.
- ↻ The context menu appropriate to the item appears (see table *Items and appropriate context menus* [▶ page 112]):
- Select context menu entry **Edit**.
- ↻ At controller, submodule and variable: The **<Item> assistant** is displayed.
- ↻ At device and module: At first, a dialog offering two options is displayed. The first option is **<Item>Select description** and second option is **Edit <item>**.
- Select the second option: Edit **<item>**
- ↻ At device and module; The **<item> assistant** is displayed.

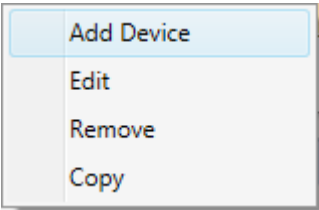
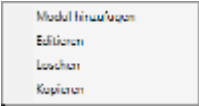
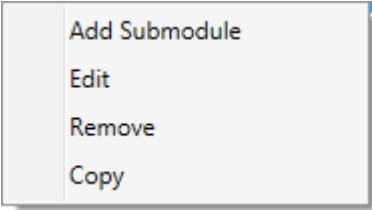
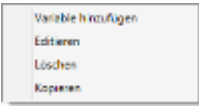
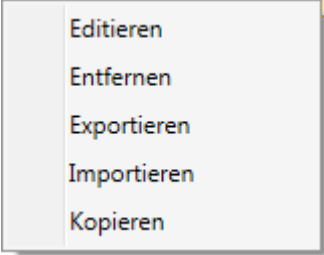
The further proceeding is explained within the sections describing the assistants:

Item/Assistant	Section containing the description
Controller	<i>Controller assistant</i> [▶ page 115]
Device	<i>Device wizard</i> [▶ page 116]
Module	<i>The module wizard</i> [▶ page 119]
Submodule	<i>Submodule wizard</i> [▶ page 121]
Variable	<i>Variable wizard</i> [▶ page 125]

Table 41: Assistants

10.1.4.3 Remove item

According context menu entry *Remove*

Item: *Variable*

This context menu entry enables you to remove an item from the item list.

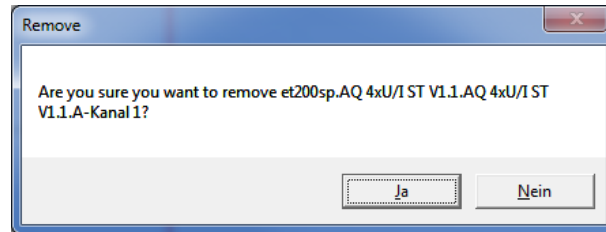

Figure 74: Remove item

In this context, the following elements of the structure tree are considered as items

- Controller
- Devices
- Modules
- Submodules
- Variables



Note:

Items can only be removed if they are not used in any other view such as Chart view or Trigger view.

10.1.4.4 Controller assistant

Figure 75: Dialog Controller Wizard:

Within dialog **Controller assistant**, the following can be specified for configuration:

Field name	Status	Meaning
Name	Mandatory field	Specify the name of your PROFINET controller here. This name can freely be chosen, however, it ,may not be empty. As long as nothing has been entered, a red frame is displayed around the input field Name and the button Finish is deactivated and grayed out.
MAC address	Optional	Specify the MAC address of your PROFINET controller here. This MAC address must be valid according to the rules applying for MAC IDs, otherwise a red frame isa displayed around the input field MAC address and the button <i>Finish</i> is deactivated and grayed out.
IP address	Optional	Here you can specify the IP address of your PROFINET controller The field may be left empty, but if an entry is made, this entry must represent a valid IP address according to the validity rules for IP addresses. In case of an invalid entry a red frame will appear around the input field IP address and the Finish button will be disabled and grayed out.

Table 42: Dialog **Controller assistant****Note:**

A valid MAC ID consists of exactly six groups of two hexadecimal values separated by colons (:). For instance, 06:0A:3B:78:05:6C would be a valid MAC ID.

In order to store the configuration of your controller entered within this dialog to your project:

- Click at Finish.
- ⇒ The entered configuration data for the device/ module/ submodule are stored within the project.
- ⇒ If for any reason you intend to leave the dialog without storing data, then click at **Cancel**.

10.1.4.5 Device wizard

Figure 76: Device wizard

In the dialog **Device wizard**, the following specifications concerning the configuration can be entered:

Field name	Status	Meaning
Name	Mandatory field	Name of the PROFINET device. As long as nothing has been entered, a red frame is displayed around the input field <i>Name</i> and the button <i>Finish</i> is deactivated and grayed out.
Device ID	Mandatory field	Specify the Device ID of your PROFINET device here which contains the device-specific part of the PROFINET identification number associated to your PROFINET device. It is defined for each individual device by the manufacturer and uniquely identifies a device amongst all devices of this manufacturer. A non-negative value between 0 and 65535 has to be specified here. You can specify the value either in decimal format in the left input field or in hexadecimal format in the right input field. The device wizard computes the corresponding hexadecimal or decimal value instantly and displays it in the other input field. If an invalid specification has been entered in this field, a red frame is displayed around the field <i>Device ID</i> and the <i>Finish</i> button is deactivated and grayed out.
Vendor ID	Mandatory field	Specify the Vendor ID of your PROFINET device containing the manufacturer-specific part of the PROFINET identification of the PROFINET device according to the rules given in PNO document 2.712 „Application Layer Services“ here (in decimal format). A non-negative value between 0 and 65535 has to be specified here. You can specify the value either in decimal format in the left input field or in hexadecimal format in the right input field. The device wizard computes the corresponding hexadecimal or decimal value instantly and displays it in the other input field. If an invalid specification has been entered in this field, a red frame is displayed around the field <i>Vendor ID</i> and the button <i>Finish</i> is deactivated and grayed out.
MAC address	Mandatory field	The MAC address of the PROFINET device. It must comply with the rules for MAC addresses (see below), otherwise a red frame is displayed around the input field MAC and the button <i>Finish</i> is deactivated and grayed out.
Vendor Name	Optional	This parameter contains the name of the PROFINET IO-Device station defined during commissioning.
Product family	Optional	Product family. This parameter should be set onto a value defined by the manufacturer indicating the product family of the PROFINET device.
Main Family	Optional	Main Family. This parameter contains a coded value specifying the main product family, i.e. the vendor specific assignment of the device to a product family. The possible main families can be taken from table PROFINET Device info (line "Main family").
Type	Optional	Type of the PROFINET device

Field name	Status	Meaning
Infotext	Optional	Descriptive text about the PROFINET device
IP address	Optional	IP address of the PROFINET-Device

Table 43: Dialog "Device wizard"

**Note:**

A valid MAC ID consists of exactly six groups of two hexadecimal values separated by colons (:). For instance, 06:0A:3B:78:05:6C would be a valid MAC ID.

1. In order to store the configured device/module/submodule you have entered within this dialog:
 - Click at *Finish*.
 - ⇒ The entered configuration data for the device/module are stored within the project.

If for any reason you do not want to store the data, you can leave the dialog by clicking at *Cancel*.

10.1.4.5.1 Select device description

The parameters of a PROFINET device can be edited using the **device assistant**.

In order to edit an item:

- Select entry **Edit** within the context menu of the device.
- ⇒ The following window appears:

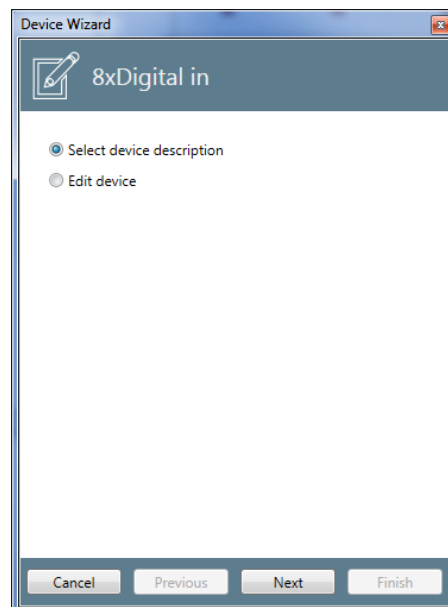

Figure 77: Device wizard - Edit device - Entry dialog

- Within the context menu select the lower option *Edit device*.
- ⇒ The **device wizard** is opened:

Section *Device wizard* [▶ page 116] describes how to proceed.

Alternatively, you may display the device description here. This is accomplished via the upper option *Select device description*.

The following window is displayed

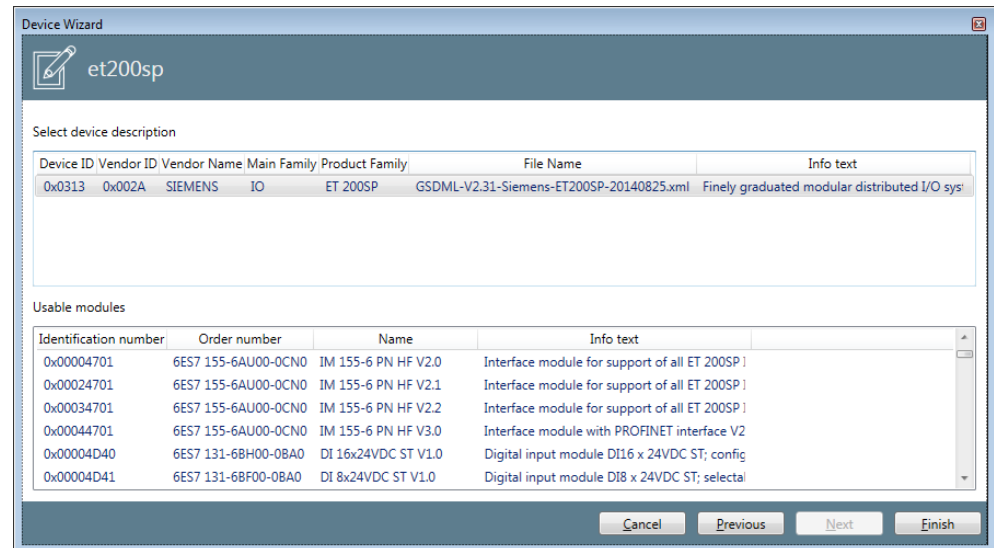

Figure 78: Device wizard - Edit device - Display of device description

10.1.4.6 The module wizard

Module wizard

IM 155-6 PN ST V1.1

Name: IM 155-6 PN ST V1.1

Identification number: 18176 (decimal) / 0x00004700 (hexadecimal)

Slot number: 0 (decimal) / 0x0000 (hexadecimal)

Additional info (optional):

Order number: 6ES7 155-6AU00-0BNO

Info text: Interfacemodul mit PROFI

Buttons: Cancel, Previous, Next, Finish

Figure 79: Module wizard - Edit module

In order to configure the module, the following specifications have to be made within the *Module Wizard*:

Field name	Status	Meaning
Name	Mandatory field	Name of module (slot). This name can freely be chosen, however, it may not be empty.
Identification number	Mandatory field	Specify the identification number of the module of your PROFINET device either in decimal format in the left input field or in hexadecimal format in the right input field. The module wizard calculates the corresponding hexadecimal or decimal value instantly and displays it in the other input field. The identification number must be a non-negative value between 0 and 4294967295. If an invalid specification has been entered in this field, a red frame is displayed around the field <i>Identification number</i> and the <i>Finish</i> button is deactivated and grayed out.
Slot number	Mandatory field	Specify the slot number of your PROFINET device in the field Slot number either in decimal format in the left input field or in hexadecimal format in the right input field. The module wizard computes the corresponding hexadecimal or decimal value instantly and displays it in the other input field. Slot numbers have to be unique within the scope of the project.. The slot number must be a non-negative value between 0 and 4294967295. If an invalid specification has been entered in this field, a red frame is displayed around the field <i>Slot number</i> and the <i>Finish</i> button is deactivated and grayed out.
Order number	Optional	Order number of module
Infotext	Optional	Descriptive text

Table 44: Dialog Module wizard– Page 1

If you specify a slot number which has already been used by another module, the following error message box is displayed:

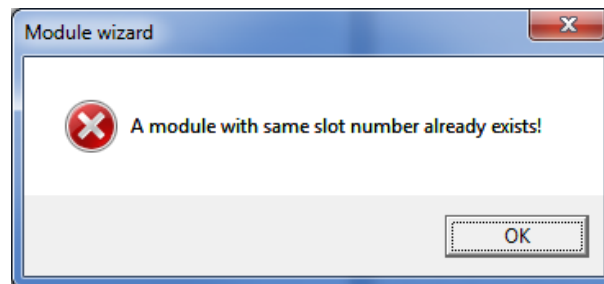

Figure 80: Error Message Box "A module with same slot number already exists!"

The following specifications are optional:

1. In order to store the configured device/module/submodule you have entered within this dialog:
 - Click at *Finish*.
 - ⇒ The entered configuration data for the device/module are stored within the project.

If for any reason you do not want to store the data, you can leave the dialog by clicking at *Cancel*.

10.1.4.6.1 Select module description

The parameters of a PROFINET module can be edited using the **module wizard**.

In order to edit an module:

- Select context menu entry **Edit**.
- ⇒ The window **Module wizard** appears

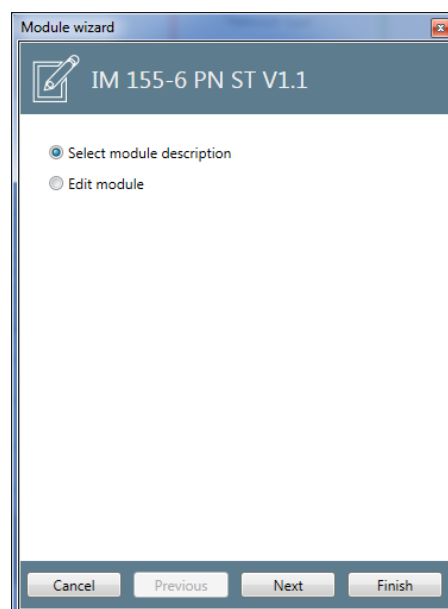

Figure 81: Module wizard - Edit module - Entry dialog

- Within the context menu select the lower option (*Edit Module*).
- The **module wizard** is opened.

Section "Module Wizard" describes, how to proceed.

Alternatively, you may display the module description here. This occurs if you choose option *Select module description*

In this case, the following window is displayed:

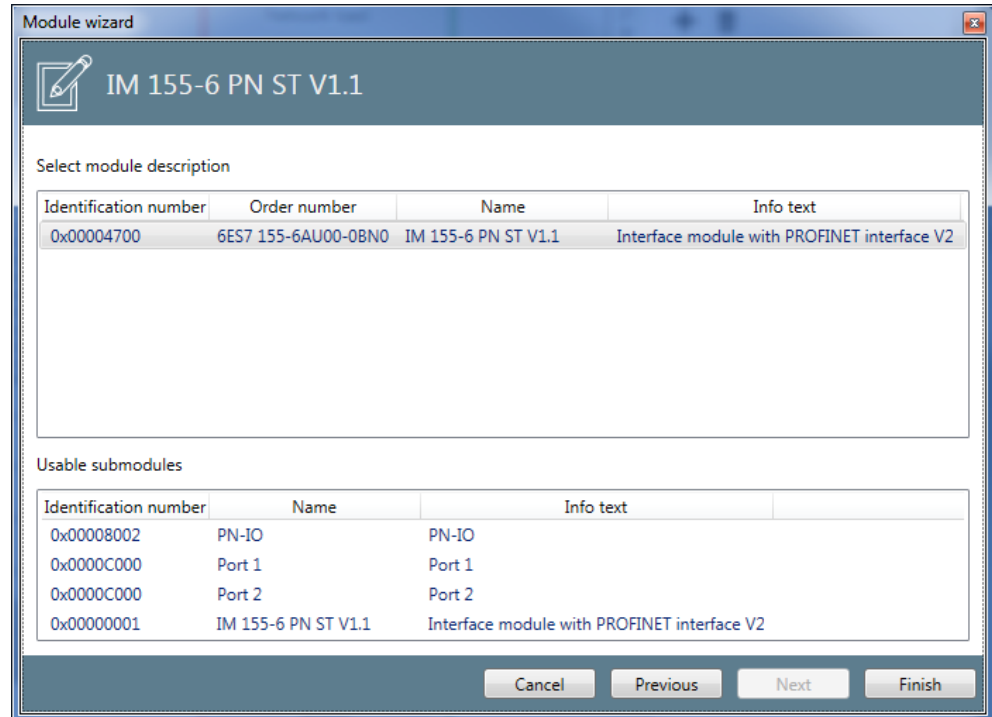

Figure 82: Module wizard - Edit module - Display of module description

The window shows information on the selected module and its applicable submodules such as identification number, name, descriptive text, for modules additionally the order number.

10.1.4.7 Submodule wizard

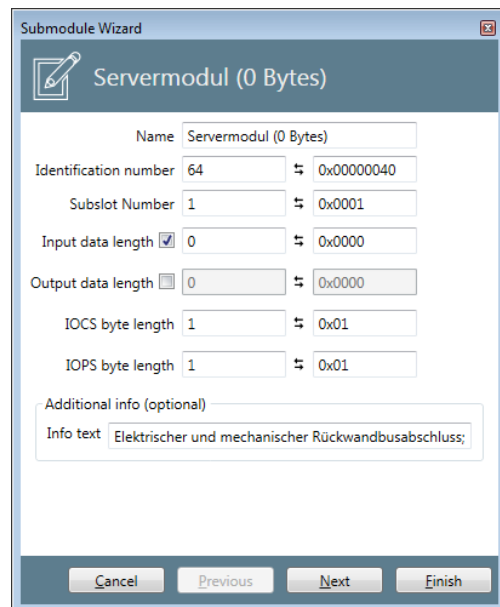

Figure 83: Submodule wizard - Edit module - page 1

Within the dialog *Device wizard*, the following configuration-related specifications can be entered:

Field name	Status	Meaning
Name	Mandatory field	The name of the submodule (subslot)
Identification number	Mandatory field	Specify the identification number of the submodule (subslot) of your PROFINET device either in decimal format in the left input field or in hexadecimal format in the right input field. The submodule wizard computes the corresponding hexadecimal (or decimal) value and displays it in the respective other input field. The identification number must be a non-negative value between 0 and 4294967295. If an invalid specification has been entered in this field, a red frame is displayed around the field <i>Identification number</i> and the <i>Finish</i> button is deactivated and grayed out.
Subslot number	Mandatory field	Specify the number of the submodule (subslot) of your PROFINET device either in decimal format in the left input field or in hexadecimal format in the right input field. The submodule wizard computes the corresponding hexadecimal (or decimal) value and displays it in the respective other input field. Subslot numbers have to be unique within the scope of the project. The subslot number must be a non-negative decimal value in the range between 0 and 65535. If an invalid entry has been made in this field, a red frame will appear around the input field <i>Subslot number</i> and the <i>Finish</i> button will be disabled and grayed out.
Input data length	Mandatory field	Specify the input data length of the submodule (subslot) of your PROFINET device either in decimal format in the left input field or in hexadecimal format in the right input field. The submodule wizard computes the corresponding hexadecimal (or decimal) value and displays it in the respective other input field. By default, this field is locked (it is grayed out and no input is possible). In order to unlock it, you have to check the little check box right beside the text <i>Input data length</i> . After unlocking the field, the field is displayed in black and you can enter a value there. The input data length must be a non-negative decimal value in the range between 0 and 65535. If an invalid entry has been made in this field, a red frame will appear around the input field <i>Input data length</i> and the <i>Finish</i> button will be disabled and grayed out.
Output data length	Mandatory field	Specify the output data length of the submodule (subslot) of your PROFINET Device either in decimal format in the left input field or in hexadecimal format in the right input field. The submodule wizard computes the corresponding hexadecimal (or decimal) value and displays it in the respective other input field. By default, this field is locked (it is grayed out and no input is possible). In order to unlock it, you have to check the little check box right beside the text <i>Output data length</i> . After unlocking the field, the field is displayed in black and you can enter a value there. The output data length must be a non-negative decimal value in the range between 0 and 65535. If an invalid entry has been made in this field, a red frame will appear around the input field <i>Output data length</i> and the <i>Finish</i> button will be disabled and grayed out.
IOCS byte length	Mandatory field	Specify the IOCS byte length either in decimal format in the left input field or in hexadecimal format in the right input field. The submodule wizard computes the corresponding hexadecimal (or decimal) value and displays it in the respective other input field. The IOCS byte length must be a non-negative decimal value in the range between 0 and 255.
IOPS byte length	Mandatory field	Specify the IOPS byte length either in decimal format in the left input field or in hexadecimal format in the right input field. The submodule wizard computes the corresponding hexadecimal (or decimal) value and displays it in the respective other input field. The IOPS byte length must be a non-negative decimal value in the range between 0 and 255.
Infotext	Optional	Here you can specify a descriptive text.

Table 45: *Dialog Submodule wizard – Page 1*

In order to advance to the second part of the submodule wizard: click at button **Next**. The following dialog appears:

Figure 84: Submodule wizard - Edit module - page 2

For all frames, it offers access to the following parameters related to frame configuration. Changing to another frame is accomplished via the selection list *Frames*, all other data specified in this dialog relate to that frame having been selected here. The following configuration options are available.

Field name	Status	Meaning
Selection list <i>Frames</i>	Selection list	The selection list <i>Frames</i> allows you to enter and select frame-related information. Clicking at the green plus-symbol creates a new frame for which information can be entered. Vice versa, the currently selected frame entry in the selection list <i>Frames</i> can be deleted just by clicking at the garbage can symbol. This includes all information stored with that frame! The following information related to the selected frame can be entered in page 2 of the Submodule Wizard dialog:
Name	Mandatory field	Specify a freely selectable name for the frame here. The default name which is used when a new frame is created is <i>Empty frame</i> .
Frame ID	Mandatory field	Specify the Frame ID here either in decimal format in the left input field or in hexadecimal format in the right input field. The submodule wizard computes the corresponding hexadecimal (or decimal) value and displays it in the respective other input field. The Frame ID must be a non-negative decimal value in the range between 0 and 65535.
Frame direction	Selection list	Specify the Frame direction here. You can choose between the options <ul style="list-style-type: none"> • Input • Output
Data byte offset	Mandatory field	Specify the data byte offset here either in decimal format in the left input field or in hexadecimal format in the right input field. The submodule wizard computes the corresponding hexadecimal (or decimal) value and displays it in the respective other input field. The data byte offset must be a nonnegative decimal value in the range between 0 and 65535.
IOCS byte offset	Mandatory field	Specify the offset of the IOCS byte here either in decimal format in the left input field or in hexadecimal format in the right input field. The submodule wizard computes the corresponding hexadecimal (or decimal) value and displays it in the respective other input field. The offset of the IOCS byte must be a non-negative decimal value in the range between 0 and 65535

Field name	Status	Meaning
SendClockFactor	Mandatory field	Specify the <i>SendClockFactor</i> here either in decimal format in the left input field or in hexadecimal format in the right input field. The submodule wizard computes the corresponding hexadecimal (or decimal) value and displays it in the respective other input field. The <i>SendClockFactor</i> must be a non-negative decimal value in the range between 0 and 65535.
ReductionRatioFactor	Optional	Specify the <i>ReductionRatioFactor</i> here either in decimal format in the left input field or in hexadecimal format in the right input field. The submodule wizard computes the corresponding hexadecimal (or decimal) value and displays it in the respective other input field. The <i>ReductionRatioFactor</i> must be a non-negative decimal value in the range between 0 and 65535.

Table 46: Dialog Submodule wizard - page 2 - frame-related aspects

If you specify a value within field *subslot number* which has already been used by another submodule, the following error message box is displayed:

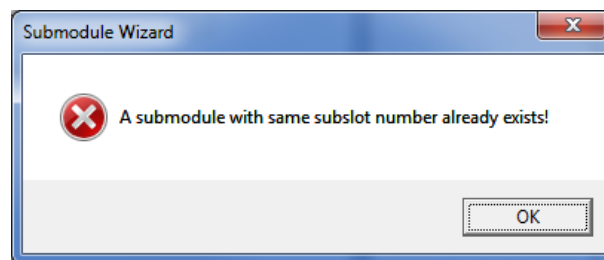

Figure 85: Error Message Box "A submodule with same subslot number already exists"



Note:

At least one of the input fields *Input data length* and *Output data length*. must be unlocked. For submodules working bidirectionally both directions are selected.

- In order to store the configured device/module/submodule you have entered within this dialog:
 - Click at *Finish*.
 - ⇒ The entered configuration data for the device/module are stored within the project.

If for any reason you do not want to store the data, you can leave the dialog by clicking at *Cancel*.

10.1.4.8 Variable wizard

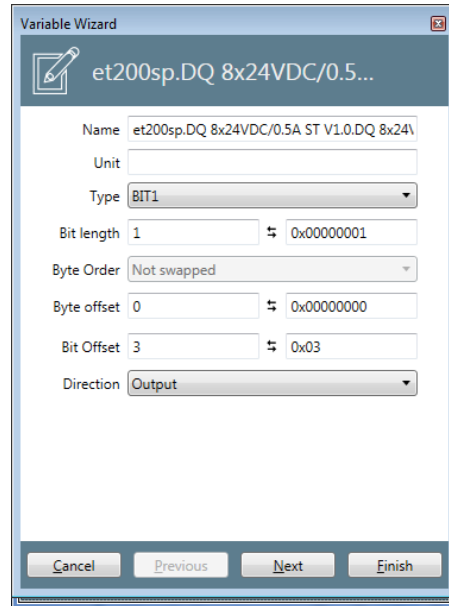

Figure 86: Variable Wizard - first page (Parameter)

Within the Variable Wizard, the following specifications concerning the configuration are made:

Field name	Status	Meaning
Name	Mandatory field	Specify the name identifying the variable to be defined here. As long as no input has been entered in to this mandatory input field, there will be a red frame around the Name field and the button Finish is deactivated and grayed out. The name will also appear in the Variable area of the variable to be defined as Name within the block Variable Info .
Unit	Optional	This field contains the unit to be applied to the variable.
Type	Optional	The data type of the variable. For a list of applicable data types see <i>List of supported data types for PROFINET variables</i> [▶ page 78].
Bit length	Optional	This field contains the size of the data type specified under Type given as number of bits. You can specify the bit length either in decimal format in the left input field or in hexadecimal format in the right input field. The submodule wizard computes the corresponding hexadecimal (or decimal) value and displays it in the respective other input field. This value depends on the selected Type . When the Type is chosen, the maximum allowed value which corresponds to the length of the data type in bits is used as default. You may specify lower values.
Byte order	Optional	Here it can be specified whether the order of bytes in a data word is swapped (Swapped) or not (Not swapped).
Byte offset	Optional	This data field contains the offset of the variable relative to the beginning of the IO data objects as a number of bytes. The byte Offset must be a nonnegative value in the range between 0 and 99. If this limit is exceeded, a red frame appears around the input field Byte Offset and the Finish button will be disabled and grayed out.
Bit offset	Optional	This data field contains the number of bits the variable is shifted at the byte offset of the IO data object. The Bit offset must be a non-negative value in the range between 0 and 7. If this limit is exceeded, a red frame appears around the input field Byte Offset and the Finish button will be disabled and grayed out.
Direction	Optional	This selection list allows you to select the signal direction to be applied, if possible. Available choices are: <ul style="list-style-type: none">• Input• Output The signal direction will also appear in the variable area of the variable to be defined as direction within the Block Variable Info.

Table 47: Dialog Variable Wizard - first page

- Click at button **Next**.
- The second page of **Variable Wizard** is displayed.

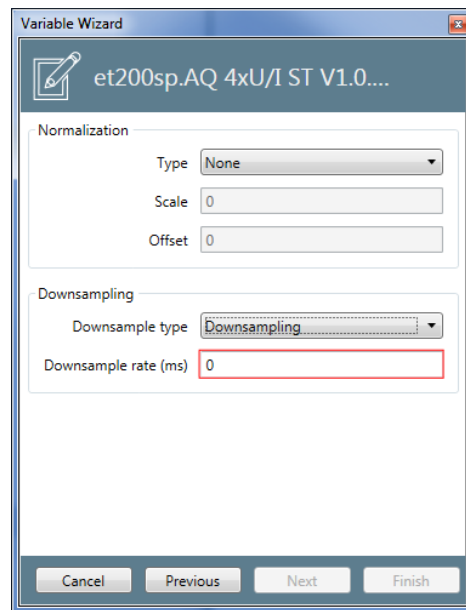

Figure 87: Dialog Variable Wizard - second page (Normalization)

On this page you can specify how to normalize the measured data (if this is desired).

The fields within the dialog **Variable Wizard** have the following meaning:

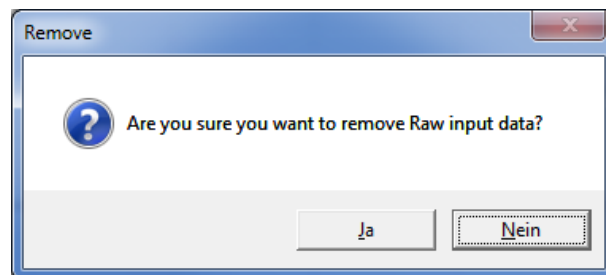

Figure 88: Dialog Variable Wizard - second page (Normalization)

On this page you can specify how to normalize the measured data (if this is desired).

The fields in dialog **Variable Wizard** have the following meaning:

Field name	Meaning
Type	The normalization type. If the option None is chosen, the values Scale and Offset are set to 0 and thus no normalization of the measured data takes place. Otherwise, it is possible to perform a customdefined normalization based on the fields Factor and Offset. During this normalization, the initial value is first multiplied with the factor Scale and then the Offset is added to the product.Scale Specify the factor Scale for the user-defined normalization
Scale	Factor Scale for user-defined normalization.
Offset	Offset for user-defined normalization.

Table 48: Dialog Variable Wizard - second page

- Click at **Finish** in order to display the configured variable in your project.
- ⇒ The entered configuration data for the variable are stored within the project.

1. In order to store the configured device/module/submodule you have entered within this dialog:

➤ Click at *Finish*.

⇒ The entered configuration data for the device/module are stored within the project.

If for any reason you do not want to store the data, you can leave the dialog by clicking at *Cancel*.

10.1.5 Dialogs of the Context Menu for EtherNet/IP

In this context, the following elements of the structure tree below of **Configuration** are considered as items:

- Controller
- Devices
- Modules
- Variables

The context menu of any item is invoked by right-clicking onto it. Depending on the chosen item, various functions can be invoked.

- Add an item
- Edit an item
- Remove an item
- Copy an item

Furthermore, for each item a wizard offers easy configuration possibilities.

10.1.5.1 Add an item

Item	Superordinate item	Appropriate context menu	Name of context menu
Controller	Configuration		Add Controller
Device	Controller		Add/ edit/ remove/ copy device
Module	Device		Add/ edit/ remove/ copy module
Variable	Module		Add/ edit/ remove/ copy variable

Table 49: Items, superordinate items and appropriate context menus

Step-by-step instructions

In order to add a new item (<item> = *controller, device, module* or *variable*):

- In order to add an item, click at the designated superordinate item within the item list using the **right** mouse button. The superordinate item is then located right above the item. Table *Items, superordinate items and appropriate context menus* [▶ page 128] indicates of which type the superordinate item should be.
- The context menu appropriate to the item appears (see table *Items, superordinate items and appropriate context menus* [▶ page 128])
- Select context menu entry **Add <Item>**.
- The **<Item> wizard** is displayed.

The further proceeding is explained within the sections describing the wizards.

10.1.5.2 Edit an item

Item	Appropriate context menu	Name of context menu
Controller		Editing a controller
Device		Add/ edit/ remove/ copy module
Module		Add/ edit/ remove/ copy variable
Variable		Edit/ remove/ copy

Table 50: *Items and appropriate context menus*

Step-by-step instructions

In order to edit an item (<item> = *controller, device, module* or *variable*):

- In order to edit an item, click at the designated item within the item list using the **right** mouse button.
- The context menu appropriate to the item appears (see table *Items and appropriate context menus* [▶ page 129])
- Select context menu entry **Edit**.
- The **<Item> wizard** is displayed.

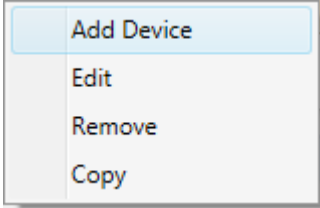
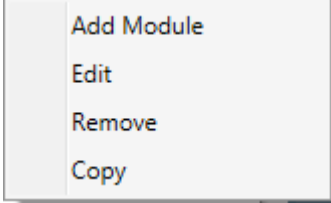
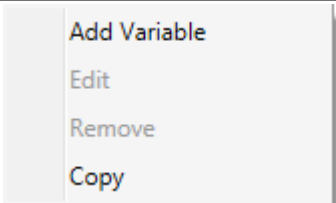
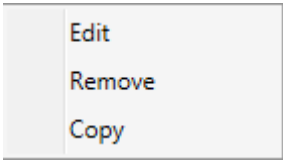
The further proceeding is explained within the sections describing the wizards.

10.1.5.3 Remove item

This context menu entry enables you to remove an item from the item list, if it is not used in any other view (such as chart view or trigger view). If you click at the entry, first a confirmation prompt is issued.

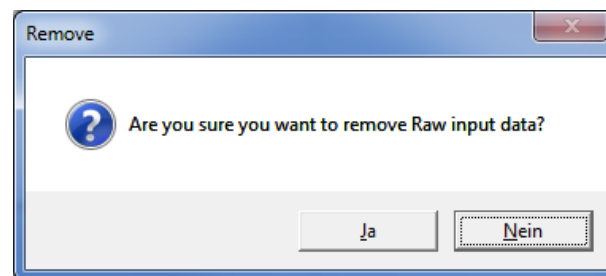

Figure 89: Remove an item

If you click at **Yes**, the item will be removed, if it really has not been used within any view. Otherwise, a respective error message is issued.

10.1.5.4 Controller wizard

Figure 90: Dialog Controller wizard

In the dialog **Controller wizard**, the following specifications regarding the configuration of the EtherNet/IP Scanner can be made:

Field name	Status	Meaning
IP address	Mandatory field	IP address of EtherNet/IP Scanner. The input must comply with the rules for IP addresses. In case of an invalid entry a red frame will appear around the input field IP address and the <i>Finish</i> button will be disabled and grayed out
Name	Optional	The name of your EtherNet/IP Scanner. This name can freely be chosen.
MAC address	Optional	The MAC address of your EtherNet/IP Scanner. If a MAC address is specified, it must comply with the rules for MAC addresses, otherwise a red frame will appear around the input field MAC address and the <i>Finish</i> button will be disabled and grayed out.

Table 51: Dialog Controller wizard

**Note:**

A valid MAC ID consists of exactly six groups of two hexadecimal values separated by colons (:). For instance, 06:0A:3B:78:05:6C would be a valid MAC ID.

In order to store the configuration entered within this dialog to your project:

- Click at **Finish**.
- ⇒ The entered configuration data for the variable are stored within the project.
- ⇒ If, for any reason, you intend to leave the dialog without storing any data, click at **Cancel**.

10.1.5.5 Device wizard

Figure 91: Device wizard

In the dialog **Device wizard**, the following specifications concerning the device configuration can be entered:

**Note:**

A valid MAC ID consists of exactly six groups of two hexadecimal values separated by colons (:). For instance, 06:0A:3B:78:05:6C would be a valid MAC ID.

Field name	Status	Meaning
IP/Node address	Mandatory field	The IP address or node address of your EtherNet/IP device (EtherNet/IP Adapter). The input must be a valid IP address. In case of an invalid entry, a red frame will appear around the input field <i>IP address</i> and the <i>Finish</i> button will be disabled and grayed out.
Name	Optional	The name of your EtherNet/IP device (EtherNet/IP Adapter). This name can freely be chosen.
MAC address	Optional	The MAC address of your EtherNet/IP Adapter. If a MAC address is specified, it must comply with the rules for MAC addresses, otherwise a red frame will appear around the input field <i>MAC address</i> and the <i>Finish</i> button will be disabled and grayed out.
Router IP address	Optional (only at CIP Routing)	The IP address of the router to which your EtherNet/IP network is attached. If an IP address is entered, it must comply with the validity rules for IP addresses. In case of an invalid entry, a red frame will appear around the input field <i>Router IP address</i> and the <i>Finish</i> button will be disabled and grayed out.
Port segments	Optional (only at CIP Routing)	Port segments of routed EtherNet/IP networks (see below).

Table 52: Dialog **Device wizard**

In order to store the configuration of your device entered within this dialog to your project:

- Click at **Finish**.
- ⇒ The entered configuration data for the new device are now stored within the project.
- ⇒ If for any reason you intend to leave the dialog without storing any data, click at **Cancel**.

The simplest way to make the specifications in the input fields **Router-IP-Address** and **Port Segments** for CIP-Routing is to take these from a Wireshark® trace of your routed EtherNet/IP network. This shall be illustrated in the following using an example:

Structure of Wireshark main window

The main window of Wireshark® is horizontally divided into three areas:

- In the upper area, you will find the list of recorded frames.
- The lower area shows both a hex dump and an ASCII dump of the frame showing 16 bytes per line (left side: hex, right side: ASCII representation).
- The center area of the main window hierarchically displays the result of the analysis of the recorded frame.

Example of identification of port segments

Within the following example, the EtherNet/IP network is to routed via three port segments.

Within the hierarchy, you can typically find the information concerning path segments within a Forward open frame of the connection manager (in the example: Frame #85)

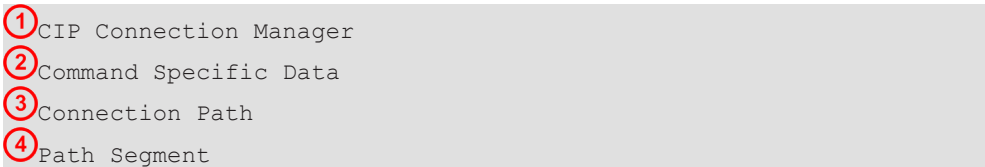

```

① CIP Connection Manager
  ② Command Specific Data
    ③ Connection Path
      ④ Path Segment
  
```

In order to find all port segments only take care of Forward open frames of the connection manager, for which in column Protocol "CIP CM" is displayed.

- Click at an appropriate frame within the upper area.
- ⇒ In the central part, the results of the protocol analysis are displayed (see below). In the lower part, the data are shown in Hex and ASCII format.
- In the central part, look for ① CIP Connection Manager and expand this entry.
- Below look for ② Command Specific Data and expand this entry.
- Below look for ③ Connection Path and expand this entry.
- Below look for ④ Path Segment (appears multiply) and expand this entry.

In the example, the first three path segments, which are specified there, are port segments, the following path segments are segments of other types.

```

Path Segment: 0x01 (Port Segment)
000. .... = Path Segment Type: Port Segment (0)
...0 .... = Extended Link Address: False
... 0001 = Port: Backplane (1)
Port Segment
Path Segment: 0x12 (Port Segment)
000. .... = Path Segment Type: Port Segment (0)
...1 .... = Extended Link Address: True
... 0010 = Port: Unknown (2)
Port Segment
Path Segment: 0x01 (Port Segment)
000. .... = Path Segment Type: Port Segment (0)
...0 .... = Extended Link Address: False
... 0001 = Port: Backplane (1)
Port Segment
...
    
```

The port segments can be found in Wireshark® at *Path segments*, They are signified by the text *Port segments*. By clicking at the respective port in Wireshark® you can determine which port segment belongs to which port.

The following table shows length and contents of the port segments in the example and directs to the respective figure of the Wireshark® trace, where the port segment belonging to the port is displayed with white text on blue background.

Port segment	Length	Data	Figure
#1	2	01 03	Port segment 1 [▶ page 134]
#2	12	12 0d 31 39 32 2e 30 2e 31 38 30 00	Port segment 2 [▶ page 135]
#3	2	01 01	Port segment 3 [▶ page 135]

Table 53: Port segments (Example)

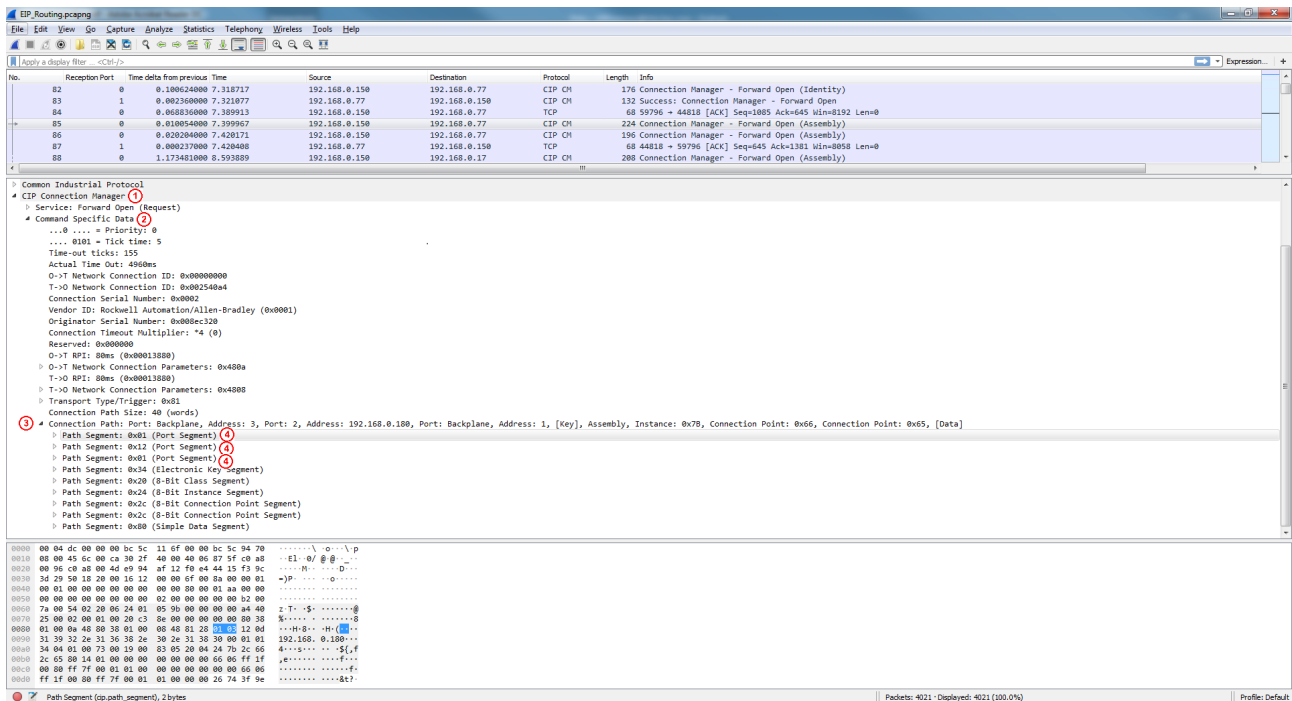

Figure 92: Port segment 1

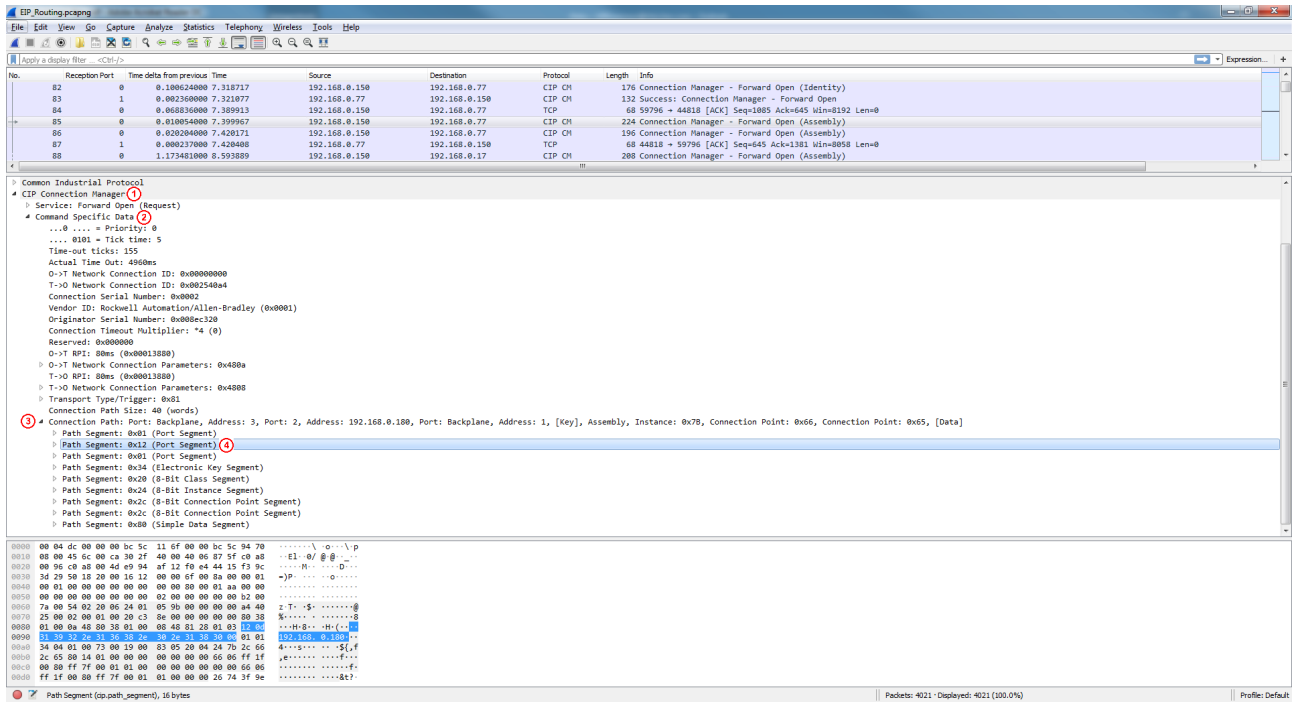

Figure 93: Port segment 2

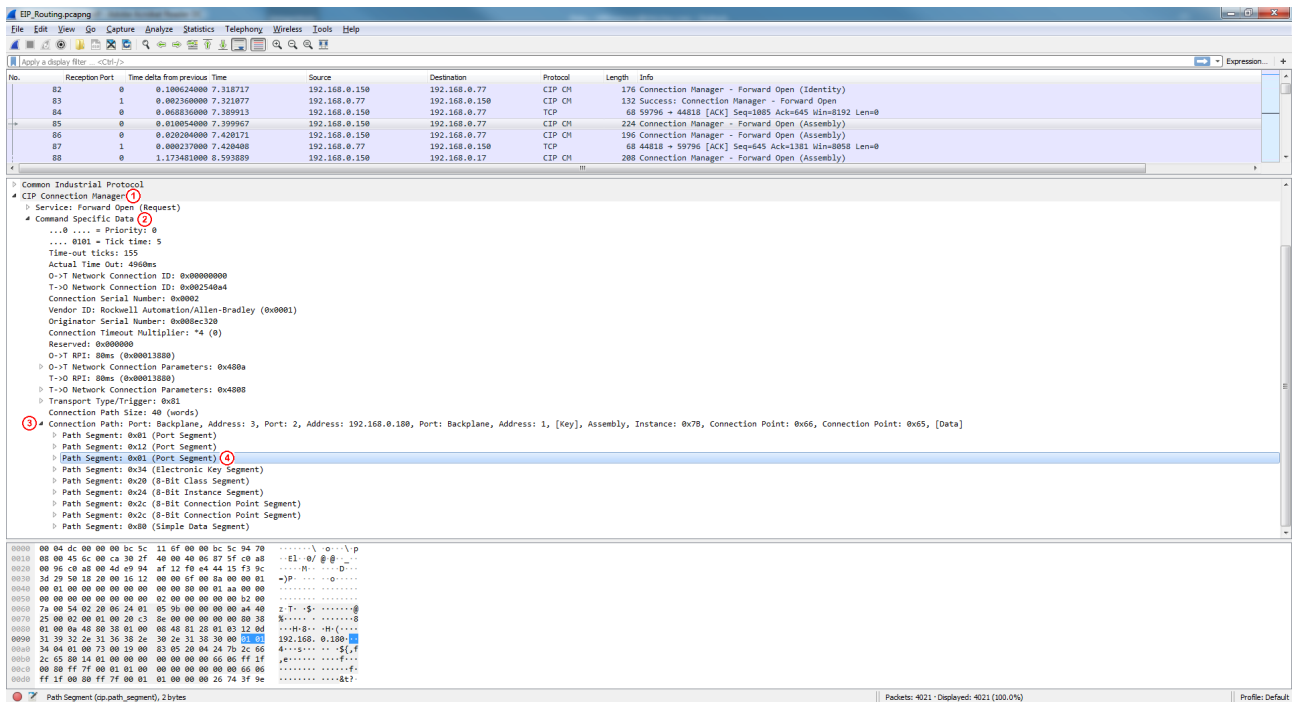

Figure 94: Port segment 3

Proceed as follows after determining the values for the input fields **Router IP Address** and **Port Segments**.

- Specify the TCP/IP address of the next EtherNet/IP router in the input field **Router IP address** within the device wizard.
- Specify the port segments having been determined as described above in field **Port Segments** within the device wizard (hexadecimal values).

**Note:**

You can find further information concerning port segments in the appendix of this document (*Addressing of devices across multiple CIP networks using port segments* [▶ page 256]).

10.1.5.6 Module wizard

Figure 95: Module wizard - Edit module

In order to configure the module, the following specifications have to be made within the *Module Wizard*;

Field name	Status	Meaning
Name	Optional	Name of module (slot). This name is optional, it may freely be chosen.
Slot number	Mandatory field	The slot number of your EtherNet/IP device (EtherNet/IP Adapter) Specify this number either in decimal format in the left input field or in hexadecimal format in the right input field. The module wizard computes the corresponding hexadecimal (or decimal) value and displays it in the respective other input field.
T->O Port	Optional	Port number for the T->O-connection(T = Target, O = Originator). The slot number must be a non-negative decimal value in the range between 0 and 65535 or hexadecimal value between 0 and 0xFFFF.
O->T Port	Optional	Port number for the O->T-connection. The slot number must be a non-negative decimal value in the range between 0 and 65535 or hexadecimal value between 0 and 0xFFFF.
T->O connection size	Optional	Connection size (Count of bytes transmitted within the connection) for the T->O-connection. This value must be a non-negative decimal value in the range between 0 and 65535 or hexadecimal value between 0 and 0xFFFF.
O->T Connection size	Optional	Connection size (Count of bytes transmitted within the connection) for the O->T-connection. This value must be a non-negative decimal value in the range between 0 and 65535 or hexadecimal value between 0 and 0xFFFF.
T->O Connection ID	Optional	Connection ID for the T->O connection. This value must be a non-negative decimal value in the range between 0 and 4294967295 or hexadecimal value between 0 and 0xFFFFFFFF.
O->T Connection ID	Optional	O->T connection ID This value must be a non-negative decimal value in the range between 0 and 4294967295 or a hexadecimal value between 0 and 0xFFFFFFFF.

Table 54: Dialog Module wizard– Page 1

Slot numbers have to be unique within the scope of the project. If you specify a *slot number* which has already been used in the definition of another module, the following error message box is displayed:

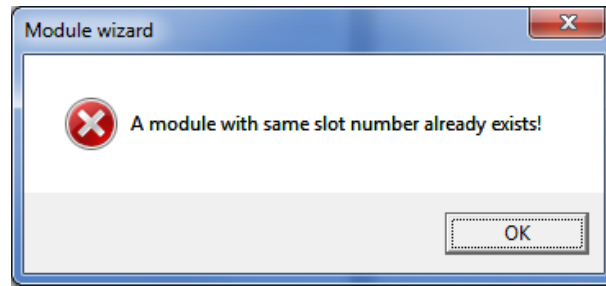

Figure 96: Error Message Box "A module with same slot number already exists!"

- Click at button **Next**.
- The second page of the **module wizard** is displayed.

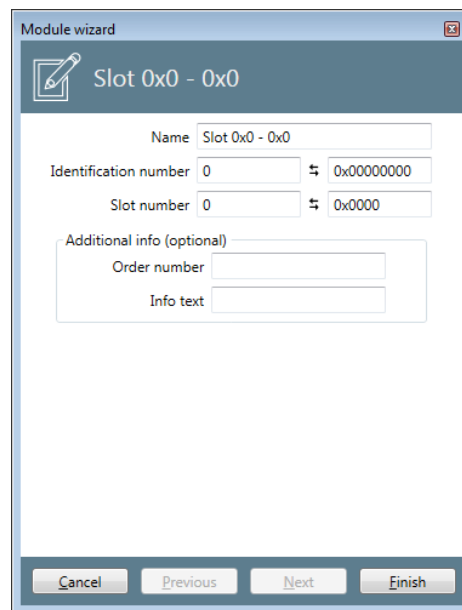

Figure 97: Module wizard - Edit module - Page 2

In order to configure the module, the following specifications have to be made here;

Field name	Status	Meaning
Vendor ID	Optional	Vendor ID This is a number uniquely identifying the manufacturer of an EtherNet/IP device worldwide. Vendor IDs are assigned by the Open DeviceNet Vendor Association, Inc. (ODVA) and by ControlNet International (CI). For instance, the value 283 means that the device has been manufactured by Hilscher. Use a non-negative integer value in the range between 0 and 65535 (0xFFFF).
Product type	Optional	General product type For instance, the value 12 (0x0C) means that the product is a communication interface. The list of possible device types is administered by the Open DeviceNet Vendor Association, Inc. (ODVA) and by ControlNet International (CI). A list of currently defined product types is available at chapter 6-1 of "The CIP Networks Library, Volume 1: Common Industrial Protocol Specification". Use a non-negative integer value in the range between 0 and 65535 (0xFFFF).

Field name	Status	Meaning
Product code	Optional	Product code This code uniquely identifies a specific product of a certain manufacturer of EtherNet/IP devices. Each manufacturer can assign this code to each of his products. The code usually relates to one or more model numbers of the manufacturer. Products should have different product codes exactly in case their configuration options or their run-time behavior differ. Use a non-negative integer value in the range between 0 and 65535 (0xFFFF).
Major revision	Optional	Major revision of the product This value is limited to a width of 7 bits. The 8th bit is reserved by the CIP standard and has to be 0 by default. The major revision should be increased by the manufacturer each time a significant change in the functionality of the product occurs
Minor revision	Optional	Minor revision of the product Minor revisions should be represented as three numbers, if necessary with leading zeroes. The manufacturer should use the minor revision to identify minor changes in product design which are not accompanied by configuration changes, such as bug fixes or exchange of hardware components.
Connection path	Optional	TCP/IP connection path Only necessary in case of CIP Routing: Specify here an ASCII string containing a part of the link address. Only necessary in case of CIP Routing: Specify here an ASCII string containing a part of the link address. The rules applying for CIP Routing are described in the appendix <i>Addressing of devices across multiple CIP networks using port segments</i> [▶ page 256]. Alternatively, the TCP IP connection path can be determined practically using a Wireshark trace similarly as described at the device wizard (see <i>Device wizard</i> [▶ page 133]).

Table 55: Dialog Module wizard– Page 2

➤ Click at button **Next**.

➤ The third page of the **module wizard** is displayed.

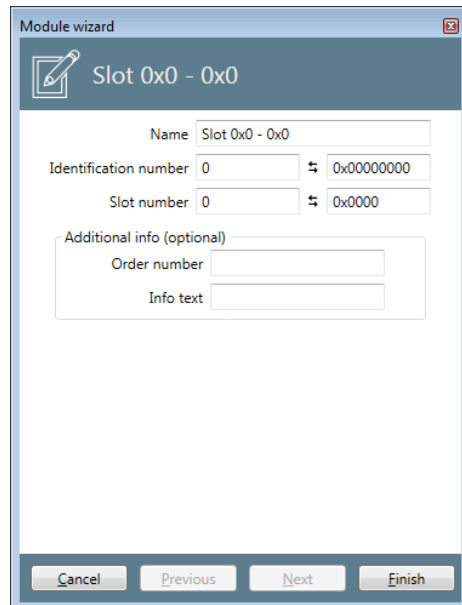

Figure 98: Module wizard - Edit module - Page 3

In order to configure the module, the following specifications have to be made here;

Field name	Status	Meaning
Transport class	Optional	Transport class defined by the CIP-Standard, selects between implicate and explicite communication. Applicable values are 0,1 and 3.
T->O Connection type	Optional	This field determines for the communication direction Target -> Originator, whether the I/O frames are sent point-to-point or as multicast. If this is unknown, the according option „Unknown“ can be chosen.
T->O Multicast IP address	Optional	At multicast communication: Multicast IP address for the communication direction Target -> Originator. Here, a valid IP address must be specified.
O->T Connection type	Optional	This field determines for the communication direction Originator -> Target, whether the I/O frames are sent point-to-point or as multicast. If this is unknown, the according option „Unknown“ can be chosen.
O->T Multicast IP address	Optional	At multicast communication: Multicast IP address for the communication direction Originator -> Target. Here, a valid IP address must be specified.

Table 56: **Dialog Module wizard– Page 3**

EtherNet/IP uses the following transport classes defined by CIP:

Transport class	Kind of communication	16 bit counter for avoidance of double packet delivery
Class 0, Null	Implicit (cyclic real-time communication)	Without 16 bit counter for avoidance of double packet delivery
Class 1, Duplicate detect	Implicit (cyclic real-time communication)	With 16 bit counter for avoidance of double packet delivery
Class 2, Acknowledged	-	
Class 3, Verified	Explicit (acyclic non-real-time communication)	
Class 4, Non-blocking	-	
Class 5, Non-blocking, fragmenting	-	
Class 6, Multicast, fragmenting	-	

Table 57: *Transport classes according to CIP standard*

In order to store the configuration of your module entered within this dialog to your project:

- Click at **Finish**.
- ⇒ The entered configuration data for the new module are now stored within the project.

If for any reason you intend to leave the dialog without storing any data:

- Click at **Cancel**.

10.1.5.7 Variable wizard

Figure 99: Variable wizard - first page (Parameter)

Within the first page of **Variable wizard**, the following specifications concerning the configuration are made:

Field name	Status	Meaning
Name	Mandatory field	The name of the variable. As long as no input has been entered in to this mandatory input field, there will be a red frame around the input field Name and the button Finish is deactivated and grayed out. This name is also displayed in the variable area of the variable to be defined within the block Variable Info, see section „Variable area“.
Unit	Optional	The unit to be applied to the variable.
Data type	Optional	The datatype of the variable. A list of suitable datatypes can be found at <i>List of supported data types for EtherNet/IP variables</i> [▶ page 83].
Bit length	Optional	The length of the data type specified under Type given as number of bits. Specify this length either in the left input field decimally or in the right input field hexadecimally. The variable wizard computes the corresponding hexadecimal (or decimal) value and displays it in the respective other input field. This value depends on the choice at Type . Each time the type is adjusted, the maximum allowed value corresponding to the length of the data type in bits, is used as default value. However, you can also select lower values. It is not allowed to specify 0. In case of an invalid entry, a red frame will appear around the input field and the Finish button will be disabled and grayed out.
Byte order	Optional	Decides whether the order of bytes in a data word is swapped (Swapped) or not (Not swapped).
Byte offset in data item	Optional	The offset of the variable to the beginning of the IO Data Object within the EtherNet/IP Frame given as number of bytes . Here, a non-negative decimal value in the range between 0 and 65534 (0xFFFFE) must be specified. If a value exceeding this limit is specified in this field, a red frame will appear around the input field and the Finish button will be disabled and grayed out.
Bit offset	Optional	The number of bits the variable is shifted at the byte offset of the IO data object. Here, a non-negative integer value in the range between 0 and 7 must be specified. In case of an invalid entry, a red frame will appear around the field Bit Offset .
Direction	Optional	Selection list for the signal direction to be applied. Applicable options are: <ul style="list-style-type: none"> • Input • Output

Table 58: Dialog Variable Wizard - first page

- Click at button **Next**.
- The second page of **Variable Wizard** is displayed.

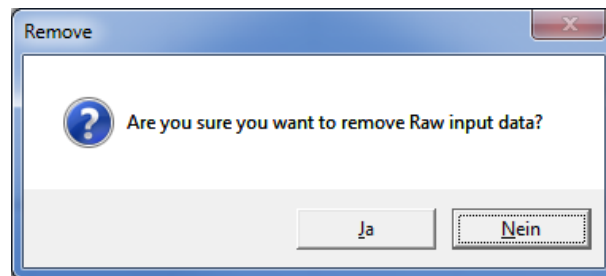

Figure 100: Dialog Variable Wizard - second page (Normalization)

On this page you can specify how to normalize the measured data (if this is desired).

The fields in dialog **Variable Wizard** have the following meaning:

Field name	Meaning
Type	The normalization type. If the option None is chosen, the values Scale and Offset are set to 0 and thus no normalization of the measured data takes place. Otherwise, it is possible to perform a customdefined normalization based on the fields Factor and Offset. During this normalization, the initial value is first multiplied with the factor Scale and then the Offset is added to the product. Scale Specify the factor Scale for the user-defined normalization
Scale	Factor Scale for user-defined normalization.
Offset	Offset for user-defined normalization.

Table 59: Dialog Variable Wizard - second page

- Click at **Finish** in order to display the configured variable in your project.
- ⇒ The entered configuration data for the variable are stored within the project.

In order to store the configuration of your device entered within this dialog to your project:

- Click at **Finish**.
- ⇒ The entered configuration data for the variable are stored within the project.
- ⇒ If, for any reason, you intend to leave the dialog without storing any data, click at **Cancel**.

10.1.6 Dialogs of the context menu for custom value filters

The context menu (of an item) is invoked by clicking at any item in the tree with the right mouse button. Depending on the chosen item, various functions can be invoked.

In the following all these functions are described each with the name of the corresponding context menu entry invoking the specific function and the item on which the function can be invoked.

The following functions of the context menu are available within the custom value tree:

10.1.6.1 Context menu functions on filter folder level

On top level (Root filter folder), the context menu looks like:

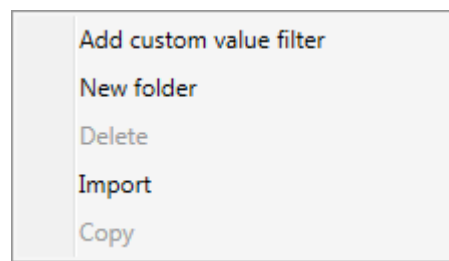

Figure 101: Context menu on top level of custom value filter tree

On level 1 (Filter folders), the context menu looks like:

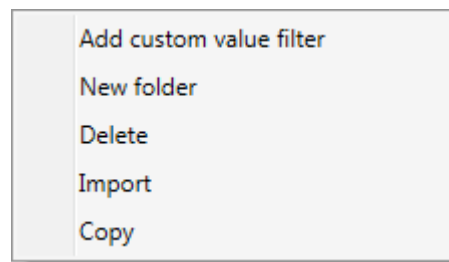

Figure 102: Context menu on level 1 of custom value filter tree

The following menu entries are applicable

Menu entry	Action	Description
Add custom value filter	Opens dialog "Edit custom value filter" for a new custom value filter	See subsection Add custom value filter
New folder	Creates a new folder	See subsection <i>New folder</i> [▶ page 148]
Delete	Deletes the current item (only available on level 1)	See subsection <i>Delete</i> [▶ page 148]
Import	Imports data from an external file	See subsection <i>Import</i> [▶ page 149]
Copy	Copies the current item (only available on level 1)	See subsection <i>Copy</i> [▶ page 149]

Table 60: Context menu functions on filter folder level

10.1.6.2 Add custom value filter

After selecting *Add custom value filter* in the context menu, the series of dialogs “Edit custom value filter” is opened in order to create a new custom value filter. The first dialog *Filter name* looks like this:

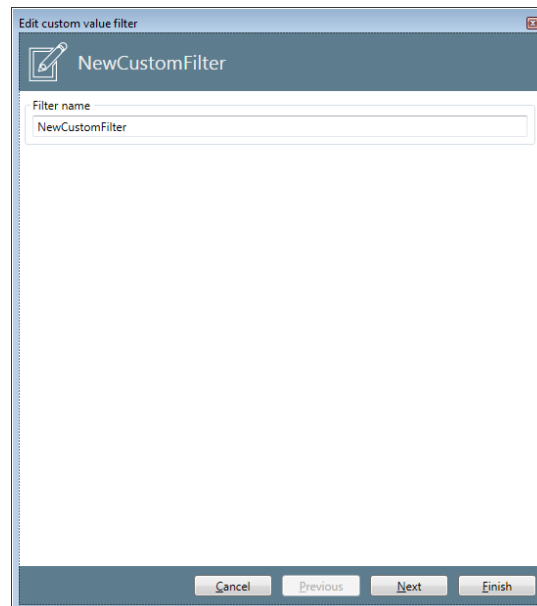

Figure 103: Add custom value filter - Dialog 1 - Filter name

- Here you can only specify the name of the filter being created (in the example: *NewCustomFilter*).
- Click *Next* to proceed to the next dialog.
- The next dialog *Filter definitions* appears:

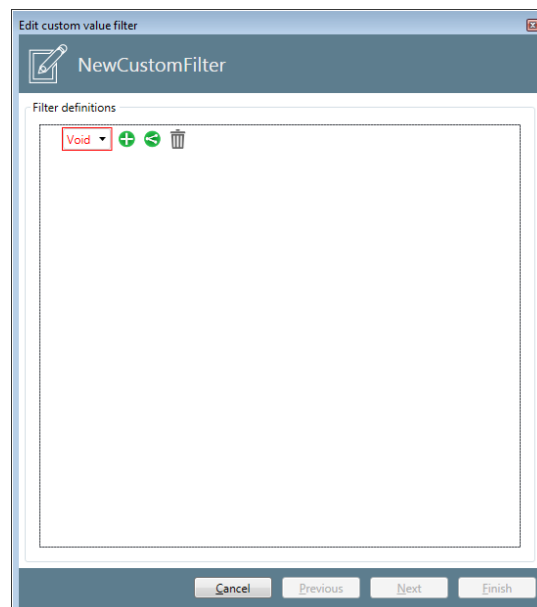



Figure 104: Add custom value filter - Dialog 2 - Filter definitions

This dialog contains an editor for filter definitions which is also used by timing and rate variables.

For instance, the simplest way of defining a filter is the following:

- Click at the green plus symbol  in order to create a new filter definition.
- Then specify a condition by selecting items from the selection lists and specifying a value for comparison. You may also add a comment in the field *Comment*.



Note:

Further information on creating more complex filter definitions for timing, rate and custom filter variables can be found in section *Editing filter conditions* [▶ page 161].

➤ The dialog should now look similar to this:

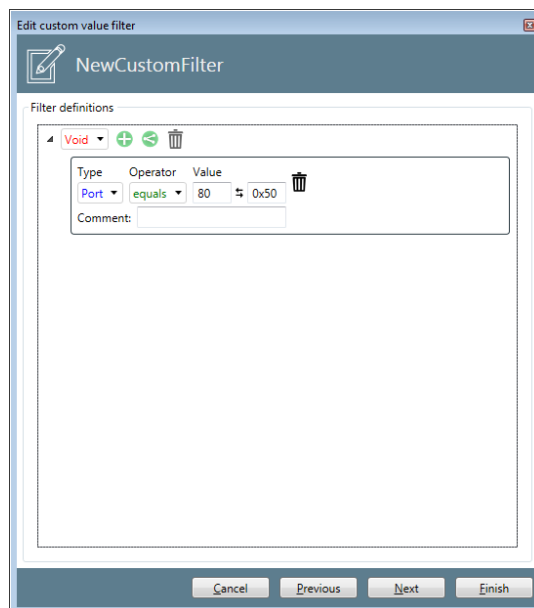

Figure 105: Add custom value filter - Dialog 2 - Filter definitions

- Click Next to proceed to the next dialog.
- The next dialog concerning the extraction behavior and parameters appears:

The next dialog deals with the extraction behavior and, if present, the extraction parameters.

The selection list Extraction behavior offers two options:

Extraction behavior	Description
Value extraction	A numeric value is extracted out of a field of an Ethernet Frame in order to visualize the sequence of values..
Event extraction	If a specific Ethernet Frame occurs, an event is visualized, however, no tangible value is extracted.

Table 61: Selection list "Extraction behavior"

All extraction parameters are only displayed and can only be edited if the option *Value extraction* has been chosen.

The following extraction parameters are available;

Figure 106: Add custom value filter - Dialog 3 - Extraction behavior and parameters

Variable type

The data type of the variable. For a list of applicable data types see *List of supported data types for PROFINET variables* [▶ page 78].

Unit

This field contains the unit to be applied to the variable.

Byte order

This selection list indicates whether the byte order is swapped (Option *Swapped*) or not (Option *Not swapped*).

Length in bits

This field contains the size of the data type specified under Type given as number of bits.

You can specify the bit length either in decimal format in the left input field or in hexadecimal format in the right input field. The submodule wizard computes the corresponding hexadecimal (or decimal) value and displays it in the respective other input field.

This value depends on the selected Type. When the Type is chosen, the maximum allowed value which corresponds to the length of the data type in bits is used as default. You can also specify lower values. Specifying 0 is not allowed. If incorrect input occurs, the field will be marked by a red frame.

Extraction position

With this selection list, you can select to which field of the Ethernet frame the relative data position refers to (byte and bit offset).

- Ethernet frame
- Ethernet payload
- TCP payload
- UDP payload

Byte offset

This data field contains the offset of the variable relative to the extraction position.

Bit offset

This data field contains the number of bits which the variable has been shifted at the beginning of the frame.

The bit offset must be a non-negative value in the range between 0 and 7. If this limit is exceeded, a red frame appears round the input field Byte. Offset and the Finish button will be disabled and greyed out.

Counting direction for offset

Using this selection list you can specify from where the offsets are counted. There are two options:

- *From begin*
 - *From end*
- Click *Next* to proceed to the next dialog.
- The next dialog *Normalization* is displayed:

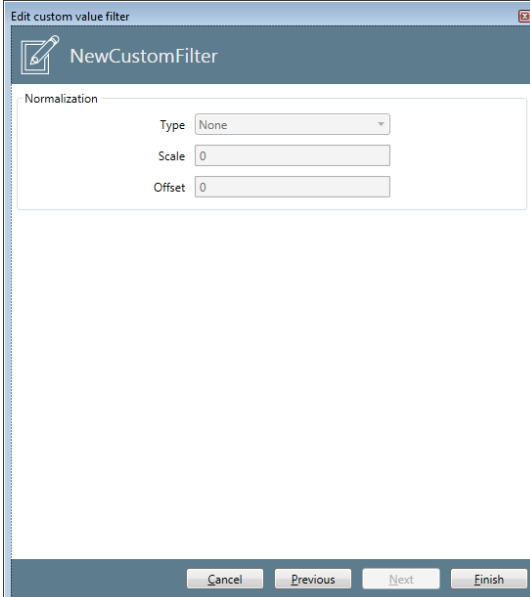

Figure 107: Add custom value filter - Dialog 4 - Normalization

Normalization area

Type

Here you can select the type of normalization to be applied from a list. The subsequently described parameters **Scale** and **Offset** depend on the selection of this type. Normalization means, that a recalculation of all values takes place for scaling in the graphical display.

In order to achieve this, the following formula is applied:

$$\text{Value}_{\text{norm}} = \text{Factor} * \text{Value} + \text{Offset}$$

where:

Value _{norm}	Value after scaling
Value	Original value prior to scaling
Scale	Scaling factor to be applied for normalization
Offset	Offset to be added

Table 62: Meanings of terms in normalization formula

Type None

If type **None** is selected, there will be normalization of the measured data and the values **Scale** and **Offset** will be set to 0 and grayed out.

Type User defined

At the type "User defined", the values **Scale** and **Offset** need to be specified manually. In order to do so, the according fields (see below) are enabled for input.

Scale

Here you can specify the factor used for normalization.

Offset

Here you can specify the offset used for normalization.

In order to store the created custom value filter:

- Click *Finish* to store the created custom value filter.
- ⇒ The custom value filter is stored with the according settings.

10.1.6.3 New folder

After selecting *New folder* in the context menu, the dialog “New folder” is opened in order to create a new folder. This dialog looks like this:

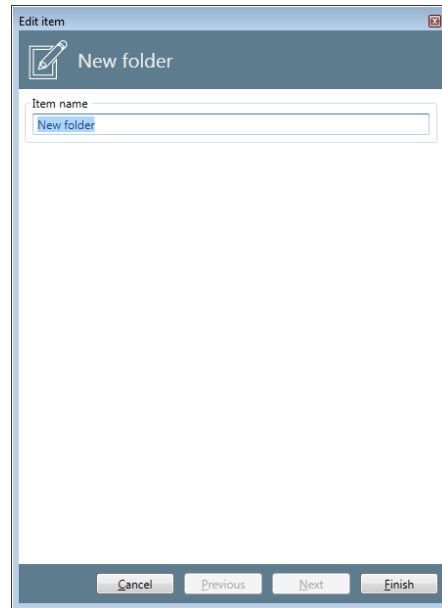

Figure 108: New folder

- You can specify the name of the new folder to be created within the field *Item name*.
- Click *Finish* in order to create the new folder.
- ⇒ The new folder is created within the item tree.

10.1.6.4 Delete

After selecting *Delete* in the context menu, the currently marked entry in the item tree will instantly be deleted without any further question.

10.1.6.5 Import

After selecting *Import* in the context menu, the following dialog appears:

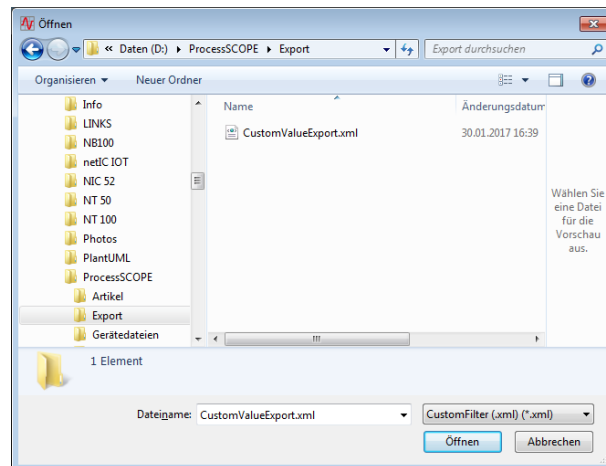

Figure 109: Import dialog

It allows you to import an XML file with data describing a custom value filter into netANALYZER Scope. (Such files can be created using the export function, see below.)

- Select such a custom filter file (* .xml).
- ⇒ If the file can be processed correctly, a new custom value filter will appear in the item tree.

10.1.6.6 Copy

After selecting *Copy* in the context menu, the currently marked entry in the item tree will instantly be copied. The name of the copied item consists of the original name plus the additional string “-copy”.

10.1.6.7 Context menu functions on filter level

On level 2 (Filter level), the context menu looks like:

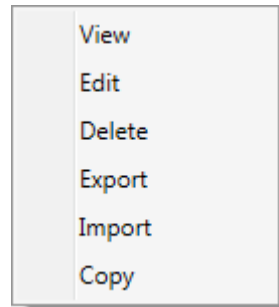

Figure 110: Context menu on level 2 (filter level) of custom value filter tree

The following menu entries are applicable

Menu entry	Action	Description
View	Opens dialog "View custom value filter"	See section <i>View</i> [▶ page 150]
Edit	Opens dialog "Edit custom value filter"	See section <i>Edit</i> [▶ page 151]
Delete	Deletes the current item	See section <i>Delete</i> [▶ page 152]
Export	Exports data to an external file	-
Import	Imports data from an external file	-
Copy	Copies the current item	-

Table 63: Context menu functions on filter level

10.1.6.8 View

The dialogs appearing after the *View* context menu entry has been selected are quite the same as those appearing after selecting the *Edit* context menu entry (the first one is displayed below). The only difference is that the *Edit* dialogs are editable contrary to the *View* dialogs.

So see subsection *Edit* [▶ page 151] for a detailed description.

10.1.6.9 Edit

After selecting Edit in the context menu, the series of dialogs “Edit custom value filter” is opened in order to create a new custom value filter. The first dialog *Filter name* looks like this:

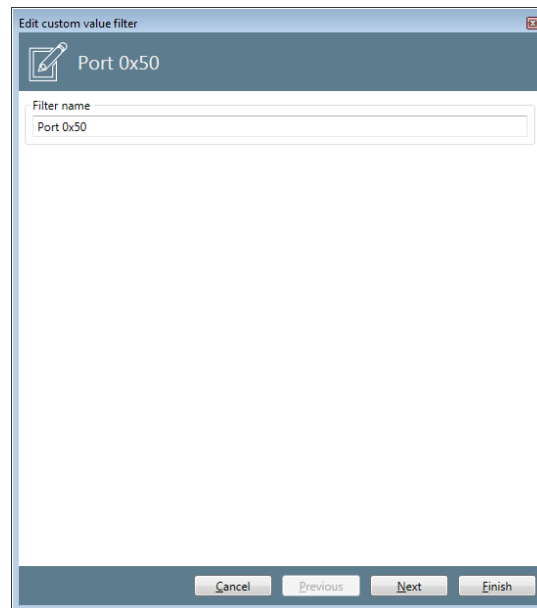

Figure 111: Edit custom value filter- Dialog 1 - Filter name

- Here you can only specify the name of the filter being created (in the example: *NewCustomFilter*).
- Click *Next* to proceed to the next dialog.
- The next dialog *Filter definitions* appears:

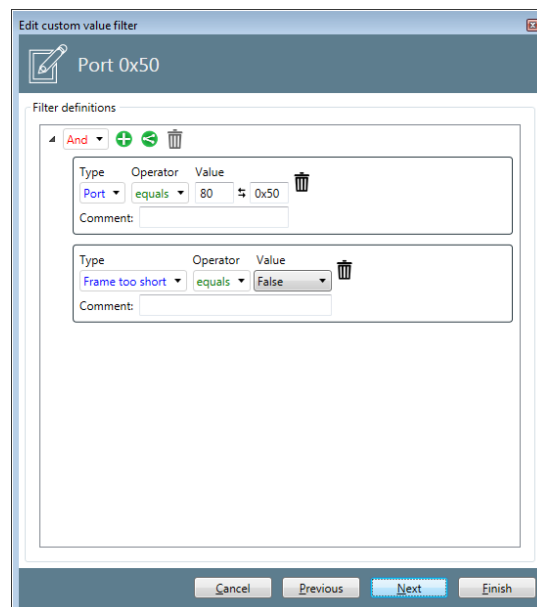

Figure 112: Edit custom value filter- Dialog 2 – Filter definitions

This dialog contains an editor for filter definitions which is described elsewhere in this manual, see below.

**Note:**

Further information on creating more complex filter definitions for timing, rate and custom filter variables can be found in section *Editing filter conditions* [▶ page 161].

10.1.6.10 Delete

After selecting Delete in the context menu, the currently marked entry in the item tree will instantly be deleted without any further question.

10.2 Quicktester events

Quicktester events set up a third stand-alone category of structure tree elements beside the device descriptions and the configuration elements, They contain the following event types:

The following list mentions all possible event types which might occur within the quicktester events.

Type	Meaning
New MAC address detected	New MAC address detected
New conversation detected	New conversation detected
Device startup detected	Device startup detected
IP Address changed	IP Address changed
Jitter threshold exceeded	Jitter threshold exceeded
Name of Station changed	Name of Station changed
PROFINET Alarm detected	PROFINET Alarm detected
Subnet mask has changed	Subnet mask has changed
Unexpected cycle counter	Unexpected cycle counter
DCP event	DCP communication detected

Table 64: Possible quicktester events within the event log

Quicktester events can be dragged out of the configuration into buckets within the chart view just like items and their evolution in time can be displayed there, see *Assigning items to the data recording view* [▶ page 170]. In the Chart View, they are displayed as lines or dots. Additionally, the quicktester events can be used as input signals for trigger conditions within the trigger view, see *Working with signals* [▶ page 204].

If the cursor is put onto a quicktester event within the chart view, a message box with the following specifications appears:

- Event type
- Source MAC address

If the mouse cursor is pointed onto this message box, a message box extensively listing all parameters of the respective event appears.

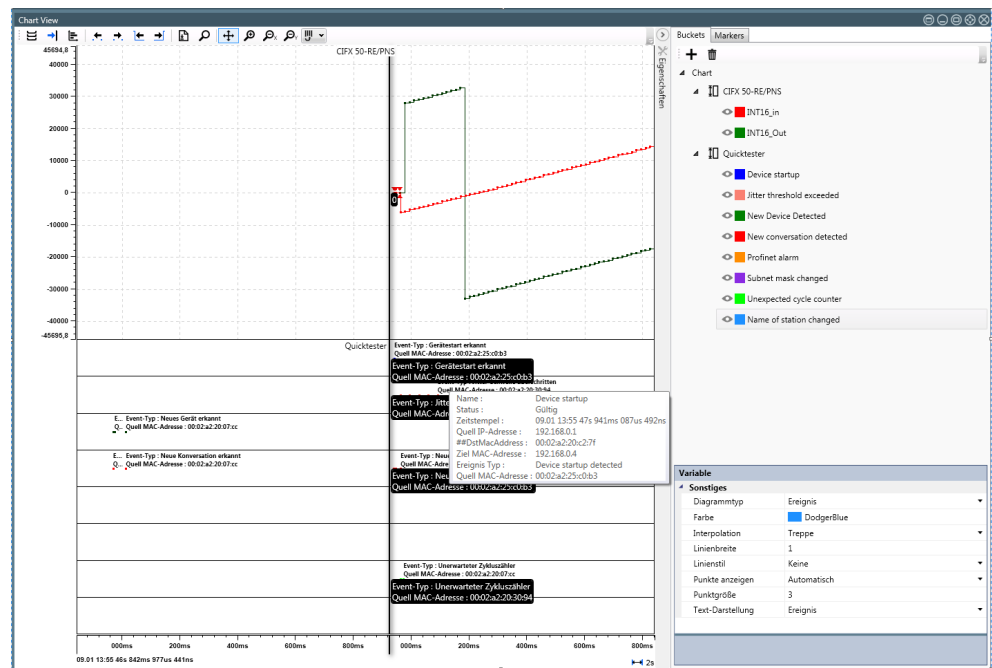

Figure 113: Quicktester events in chart view

10.3 Defining a timing variable

Timing variables allow acquiring timing information from the Ethernet datastreams. You can define suitable filter conditions for your analysis here.

A new timing variable can be added to the item list below any folder in the *network timing* tree.

1. In order to add a timing variable directly below the object *Network Timing*:
 - Click at any folder below *Network Timing* using the right mouse button.
 - Then the context menu looks like this:

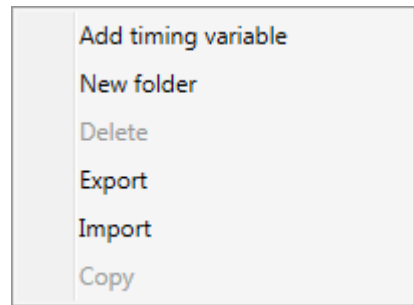

Figure 114: Context menu entry at Network Timing

2. In order to add a timing variable to a folder below the object *Network Timing*:
 - Click at any folder below *Network Timing* using the right mouse button.
 - Then the context menu looks like this:

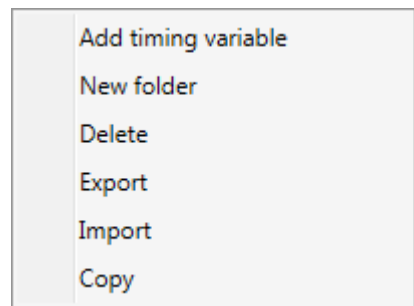

Figure 115: Context menu at folder in Network Timing tree

3. In both cases proceed as follows to add a timing variable.
 - Select context menu entry **Add timing variable**.
 - The first page of the dialog **Edit variable** appears:

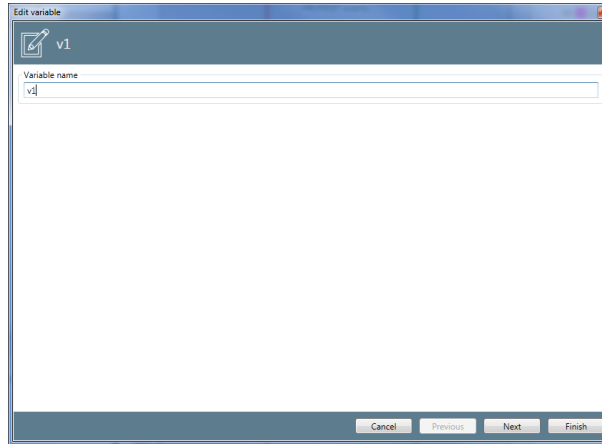

Figure 116: Dialog Edit variable - first page

- Under *Name*, specify here the name identifying the timing variable in future.
- Click *Next*.
- The second page of the dialog **Edit variable** appears:

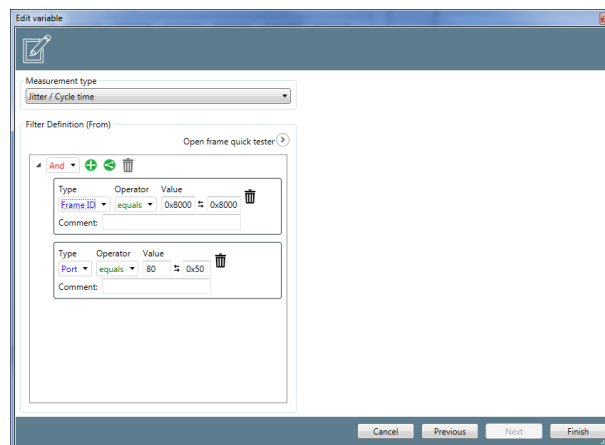

Figure 117: Dialog Edit variable - second page

In the dialog **Edit variable** the following parameters can be specified:

Type

In this selection list, the type of measurement to be performed can be specified:

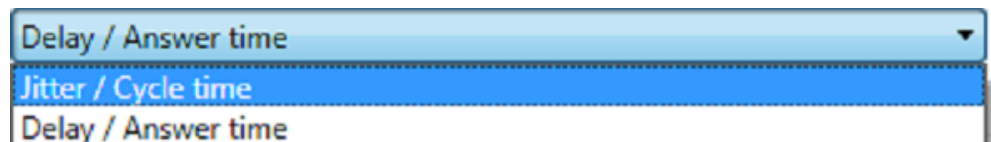

Figure 118: Type selection list

Recommendations:

- For cycle time and jitter measurements, select option *Jitter / Cycle time*.
- For answer time and delay measurements, select option *Delay / Answer time*.

Filter definition (from)

Defines the filter condition for for the Cycle/Jitter. For this type of measurement, only a frame filter is set as always the same frame type is observed within this measurement. The distance in time between to subsequent equal frames is measured.

Filter definition (to)

For the *Delay* mode an additional second filter definition is set here. The time measurement is always performed between the reception time of the frame defined in *Filter Definition (From)* and the reception time of the frame defined in *Filter Definition (To)*. In order to perform a measurement of the run-through time you would specify port0 in *Filter Definition (From)* and port2 in *Filter Definition (To)*.

The editor area works in the same way for incoming and outgoing data and is commonly described in section *Editing filter conditions* [► page 161].

Example

In order to measure the rate of IP frames at port 0, you have to specify:

- Detect IP frames using *IP frame is present*.
- Adjust port to 0 using *Port equals 0*.
- As both conditions have to be met, the logical operation to apply is *And*.
- So your filter definition should look like this:

The screenshot shows a filter definition editor with a logical operator dropdown set to 'And'. There are two filter conditions defined:

Type	Operator	Value
IP frame	is present	
Port	equals	0

Each condition has a 'Comment' field below it, which is currently empty. The interface also includes icons for adding (+), removing (-), and deleting (trash) conditions.

Figure 119: Example (detect IP frames at port 0)

4. In order to define filters according to this example, you have to proceed as follows:

- Single-click at **Void**.
- ⇒ The selection list for the operator opens.

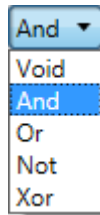

- Select **And**.
- ⇒ The top bar of the editor area should now look like:



- Click **+**.
- ⇒ A new line (i.e. condition) is created.
- Click *Port* and select IP Frame from the list.
- ⇒ In this line *IP Frame is present*:

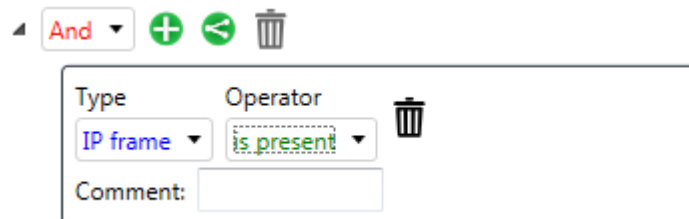

- Click **+**.
- A new line (i.e. condition) is created.
- Port is already selected. In order to enter the desired port number, enter 0 right of *equals* into the entry field with a red frame.
- ⇒ The red frame around the entry field disappears as a valid input has now been made.

10.4 Defining a rate variable

Rate variables allow acquiring information about the frequency of specific frame types or events from (Ethernet) datastreams. You can define suitable filter conditions for your analysis here.

A new rate variable can be added to the item list below any folder in the *Network rate* tree.

In order to add a rate variable directly below the object *Network rate*:

- Click at *Network rate* using the right mouse button.
- Then the context menu looks like this:

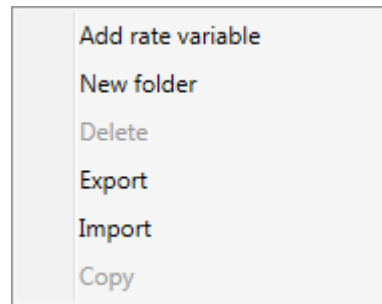

Figure 120: Context menu entry at *Network Rate*

In order to add a rate variable to a folder below the object *Network rate*:

- Click using the right mouse button at any folder below *Network rate*.
- Then the context menu looks like this:

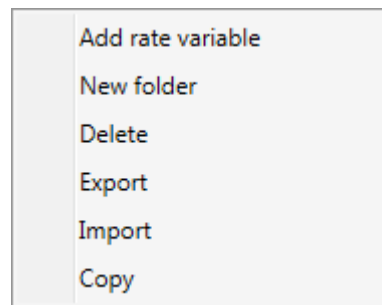

Figure 121: Context menu at folder in *Network Rate* tree.

In order to add a rate variable, proceed in both cases as follows:

- Select context menu entry **Add rate variable**.
- The first page of the dialog **Edit variable** appears:

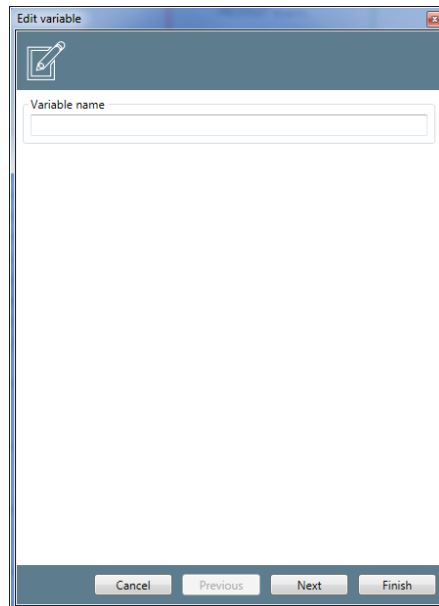

Figure 122: Dialog Edit variable - first page

- Under *Name*, specify here the name identifying the rate variable in future.
- Click at button *Next*.
- The second page of the dialog **Edit variable** appears:

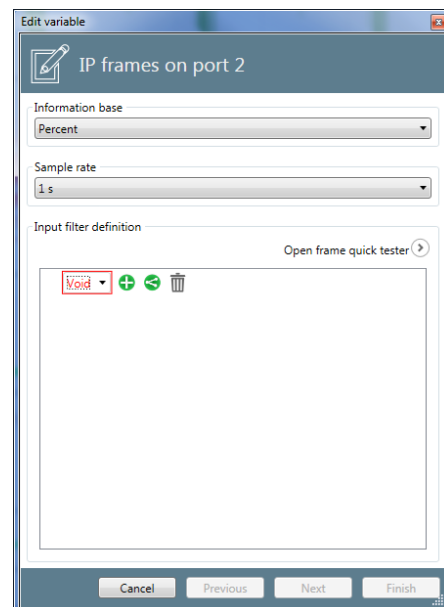

Figure 123: Dialog Edit Variable - second page

In the dialog **Edit variable** the following parameters can be specified:

Information base

With this selection list, you can decide if you want to represent the measured values as percent values or absolute values (counts).

Sample rate

With this selection list, you can switch the unit of the sample rate between 1 second and 1 millisecond.

Input Filter Definition

In this editor area, a filter condition for incoming data can be edited.



Note:

The editor area is commonly described in section Editing filter conditions *Editing filter conditions* [▶ page 161].

10.5 Editing filter conditions

Editing filter conditions

In the dialogs for specifying timing and rate variables there are one respectively two area(s) for specifying the filter conditions for these variables. These areas work in exactly the same way and shall be described in the following:

You can specify filter conditions and link these logically with one another.

A filter condition is displayed in a framed box.

This is done using the icon bar at the top edge of the editor area; see the subsequent table:

Icon	Position	Meaning
	1	Compress subtree
	1	Expand subtree (if formerly compressed)
Void And Or Not Xor	2	Selection list of applicable operators (void, and, or, not, xor)
	3	Add a new box in order to specify a condition
	4	Add a sub condition
	5	Delete

Table 65: Icons in top bar of filter editor area

Using the selection list for logical operators at position 2

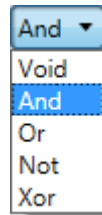



you can select the correct logical operator to be applied for the conditions in the subsequent boxes. You can add new boxes with the  icon where each new box corresponds to a filter criterion.



Note:

How to define new filter conditions by editing these boxes, is described in the following section *Editing filter conditions* [ page 162].

Expressions belonging together which have to be evaluated with priority such as the contents of brackets in logic expressions, can be put in using the  icon. By clicking at the  icon, the entire line can be deleted.

Filter criteria

Each box in the editor area represents a filter criterion in this context. A filter criterion consists of

- a filter object type
- an operator
- a test value for comparison (except test for presence)

a test value for comparison (except test for presence)

The following test conditions are applicable in filter criteria:

- Test for presence
- Test for equality or inequality
- Test for change (of value)
- Arithmetic comparison (four types: is less than, is greater than, is less than or equal, is greater than or equal)

The test condition depends on the chosen filter object type.

The test value for comparison can be entered into a input field having a red frame around it as long as no valid input has been entered.

The following table displays all available test variables along with their types and their corresponding test conditions:

Filter object	Applicable test conditions							Data type and range of values of comparison value
	(1)	(2)	(3)	(4)	(5)	(6)	(7)	
Port		X					X	Numerical / 0..255
GPIO		X						Numerical / 0..255
Long preamble		X					X	Logical/ TRUE or FALSE
Short preamble		X					X	Logical/ TRUE or FALSE
Frame too short		X					X	Logical/ TRUE or FALSE
SFD Error		X					X	Logical/ TRUE or FALSE
Frame too long		X					X	Logical/ TRUE or FALSE
Alignment error		X					X	Logical/ TRUE or FALSE
RX error		X					X	Logical/ TRUE or FALSE
Source MAC		X					X	Valid MAC ID
Destination MAC		X					X	Valid MAC ID
Destination MAC broadcast		X					X	Logical/ TRUE or FALSE
Destination MAC multicast		X					X	Logical/ TRUE or FALSE
VLAN tag	x							
VLAN tag control information (TCI)		x	x	x	x	x	x	Numerical / 0..65535
Ethertype		x	x	x	x	x	x	Numerical / 0..65535
PROFINET frame	x							
Frame ID		x	x	x	x	x	x	Numerical / 0..65535
IP Frame	x							
Source IP		x					x	Valid IP address
Destination IP		x					x	Valid IP address
ICMP	x							
IP v6 Frame	x							
IP v6 multicast		x					x	Logical/ TRUE or FALSE
TCP Frame	x							
TCP source port		x	x	x	x	x	x	Numerical / 0..65535
TCP destination port		x	x	x	x	x	x	Numerical / 0..65535
UDP frame	x							
UDP source port		x	x	x	x	x	x	Numerical / 0..65535

Filter object	Applicable test conditions							Data type and range of values of comparison value
	(1)	(2)	(3)	(4)	(5)	(6)	(7)	
UDP destination port		x	x	x	x	x	x	Numerical / 0..65535
RT Class UDP	x							
RTA Class UDP	x							
LLDP frame	x							
ARP frame	x							
MRP frame	x							
SNMP frame	x							
EtherCAT frame	x							
FCS OK		x					x	Logical/ TRUE or FALSE

Table 66: Test variables in filter definitions, their corresponding test conditions, data types and allowed ranges of values

Column	Test conditions	Operator
1	Presence	is present
2	Equality/ inequality	equals / not equals
3	is less than	is less than
4	is greater than	is greater than
5	is less than or equal to	is less than or equal to
6	is greater than or equal to	is greater than or equal to
7	Change of value	changed

Table 67: Applicable test conditions / operators

10.5.1 Example - Create filter condition for a rate variable

The following example shows how to create a rate variable in order to determine the number of registered IP frames at port 2 of the netANALYZER per millisecond. Two input filters must be defined:

On the first hand, at IP frame the option *is present* must be selected, On the other hand, port 2 must be selected.

Proceed as follows:

- Via the context menu open the dialog *Edit variable*
- Select option *And* in the selection list, see figure.

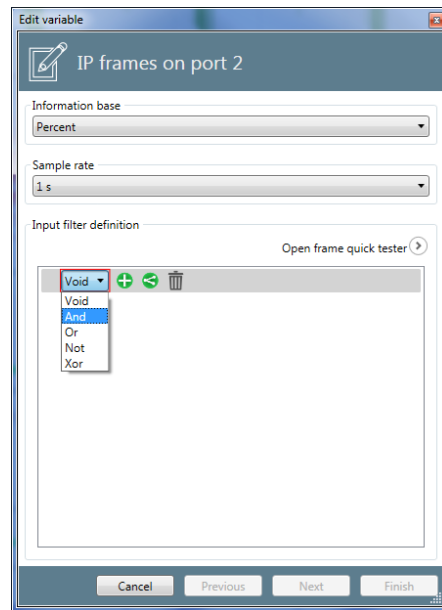



Figure 124: Dialog box *Edit variable* - Selection of the *And* operation.

For an *And*-operation, you need (at least) two filter criteria.

- For specifying the first filter criterion *IP frame is present* click at the  symbol.
- A box for specifying the filter criterion appears.
- Then select the entry *IP Framedirectly* below *IP* within the selection list *Type*, see figure:

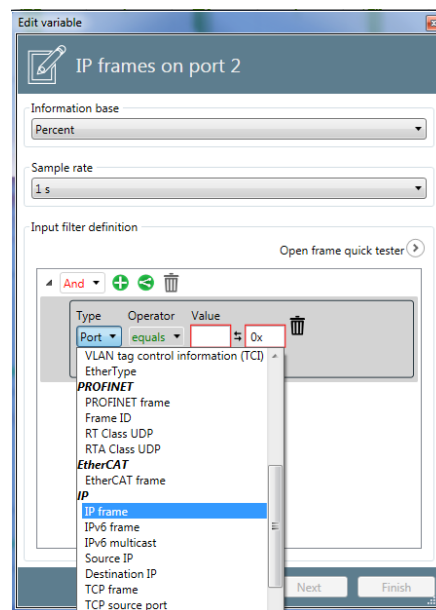

Figure 125: Dialog box *Edit variable* . Entry *IP frame* in selection list *Type*.

- Set the sampling rate to 1 ms in the selection list *Sampling rate*.
- At *Operator* select the option *is present* in order to test for presence of IP frames (at port 2).
- The first filter criterion *IP frame is present* is now completely specified and displayed within the box.

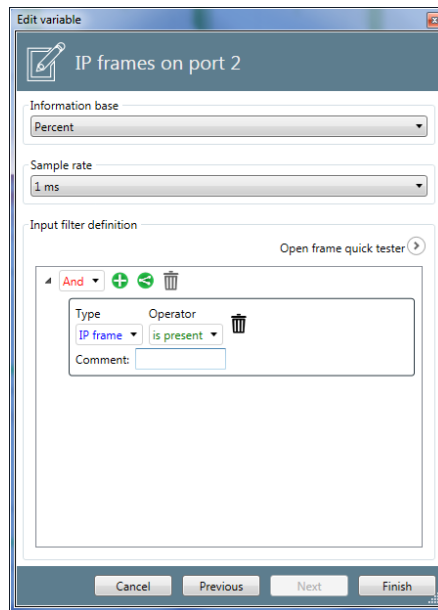



Figure 126: Dialog box Edit variable - After specifying the first filter criterion IP frame is present.

- You may write an additional comment into input field Comment eingeben, for instance *Test for usage of port 2*.

Now the second filter criterion must be specified.

- For specifying the second filter criterion *Port equals 2* click onto the symbol  once again.
- A second box for specifying a filter criterion appears.

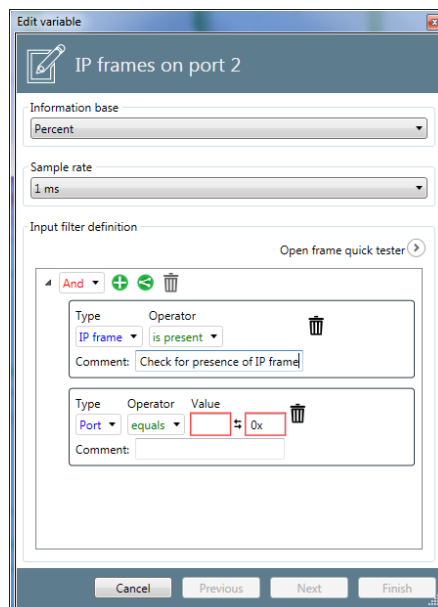

Figure 127: Dialog box Edit variable - Specifying the second filter criterion Port equals 2,

- Below "Type" select *Port*. This is the default option.
- Below "Operator" select *equals*. This is again the default option.
- Specify the value to be compared here. For selecting port 2, simply specify 2.
- The color of the red frame around the mandatory input field Value turns to black as soon as an input is made.

- Again, you may write an additional comment into the input field Comment, for instance *Test for usage of port 2*.
- Now the dialog looks as follows.

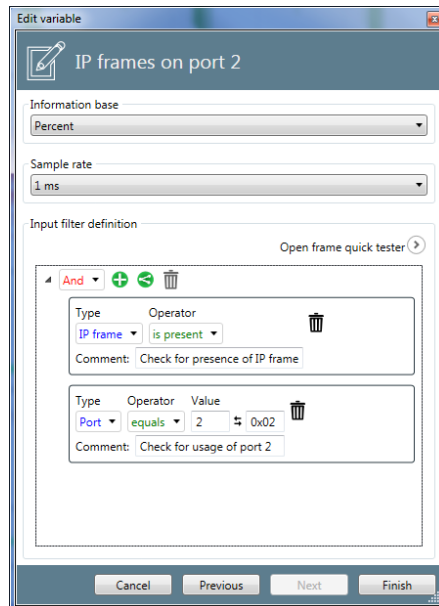

Figure 128: Dialog box *Edit variable* - After specifying the second filter criterion *Port equals 2*.

- Click at *Finish*.
- ⇒ The variable definition is finally stored.

10.5.2 Frame quicktester

In the filter definitions of the editor dialogs for timing and rate variables and custom defined filters you can use the frame quicktester.

- In order to open the frame quicktester click at the icon with the arrow showing to the right side within a circle.
- The dialog now looks as follows:

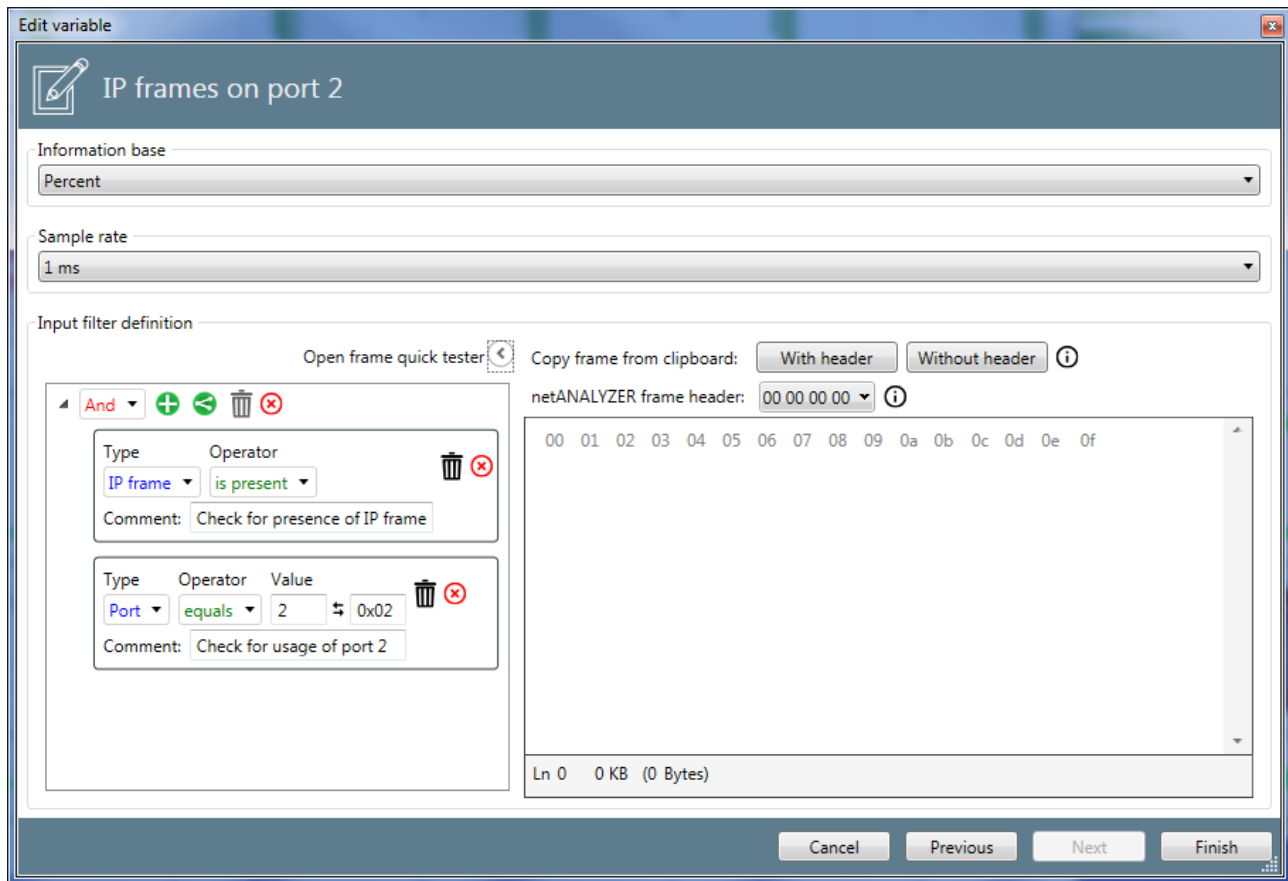

Figure 129: Frame quicktester

➤ The frame quicktester is now displayed at the right side of the dialog.

It consists mainly of a display window showing 16 bytes of the frame per line.

You can copy frames from the Microsoft Windows® clipboard (e.g. frames coming originally from Wireshark®) directly into this quicktester display window using the buttons *With header* and *Without header* and test these.

In order to copy a frame to the frame quicktester within Wireshark®:

- Select the desired frame within Wireshark®.
- Open the context menu in Wireshark® and select menu entry „Copy“.
- You can select one of these three methods for data transfer in Wireshark®:
 1. Hex + ASCII-Dump
 2. Hex-Dump
 3. Hex-Stream
- Copy the frame data from the clipboard into the frame quicktester by clicking at one of the buttons *With header* and *Without header*. Only use the button *With header* if the frame data have a netANALYZER header. You can decide this using the Wireshark® packet details-window. If there is an entry „netANALYZER“, then the frame has a netANALYZER header. and you should paste it using the button *With header*, otherwise using the button *Without header*.

Editing the netANALYZER header

If necessary, the netANALYZER header can afterwards be edited within the Frame Quicktester independently whether the inserted frame has been inserted with or without header.

In order to do so click at the rectangle right to the text *netANALYZER-Frame Header*.

The following input mask appears:

- Make the according specifications, the bits in the netANALYZER header will be set accordingly.

10.6 Display data

The Chart View allows to display some items like the contents of variables, registers or events graphically in a common window that is also denominated as the data recorder window. All displays of the various single items share a common (horizontal) time axis while each single item has its own individual (vertical) value axis as shown in the subsequent figure:

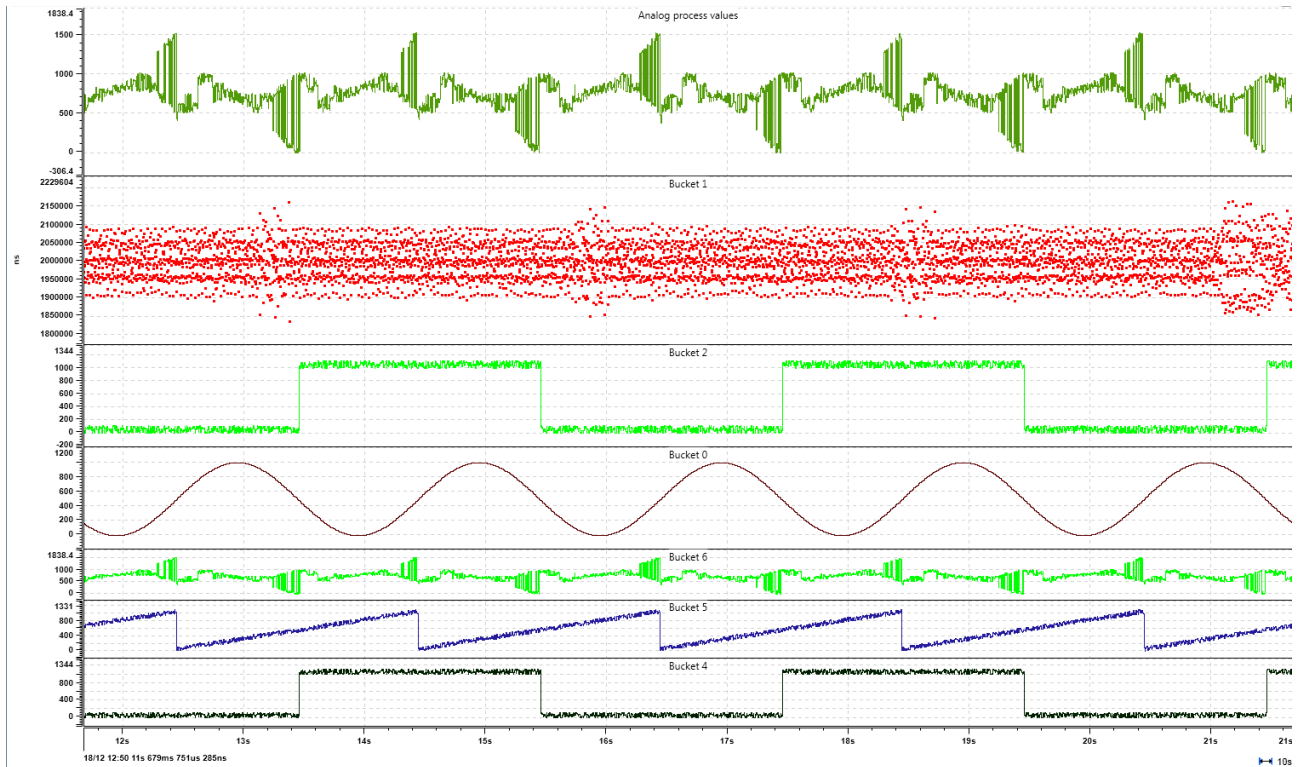

Figure 130: Example of data recorder window (Chart View)

The items to be displayed in the Chart View can be selected within an item list window and pulled to the Chart View using drag & drop, see section *Assigning items to the data recording view* [▶ page 170].



Note:

Values with invalid status are marked by red triangles within the Chart View, also see preceding figure. The following applies only to EtherCAT: Values for which the direction detection could not be completed unambiguously are marked with blue triangles.

10.6.1 Open a new view

In order to open a new Chart View:

- Click at the Menu button in the menu bar of the side menu.
- ⇒ The menu appears:
- If the sub menu Views is not open, click at Views.
- ⇒ Now the menu should look as displayed below:
- ⇒ A Chart View within the application window of netANALYZER Scope is opened. It should look similar to the figure shown in section *Display data* [▶ page 169].

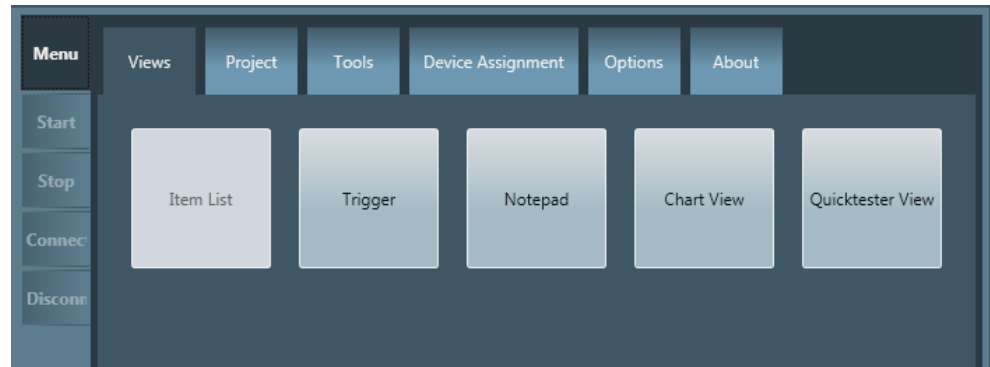

Figure 131: Menu entry "Chart View"

10.6.2 Assigning items to the data recording view

The items to be displayed need to be assigned to the Chart View.

Before items can be assigned to the Chart View using the drag & drop feature, buckets must be defined.

- Create buckets for the data you want to display in your Chart View according to your needs. Use the "Add new bucket function" (see *Working with Buckets* [▶ page 180]) to create new buckets.
- ⇒ Now you can assign the data to the newly created buckets.

Use the drag & drop technique in order to assign a single item to the Chart View:

- Drag the chosen item from the item list window and drop it at the bucket of your choice within the Chart View, where you want the item to be displayed.
- ⇒ Now, within a few seconds the Chart View should be updated and the item should be visible there. If you nevertheless do not see the data in the according bucket, you may have to scale the bucket accordingly using Zoom-in or Zoom-out.

Example

The subsequent figure shows within its right part a Chart View displaying three different items chosen from the item list window on the left within two buckets. The colored lines indicate from where within the item list window the items are dragged to which position within the Chart View. In this example, the dragging direction is always from left to right.

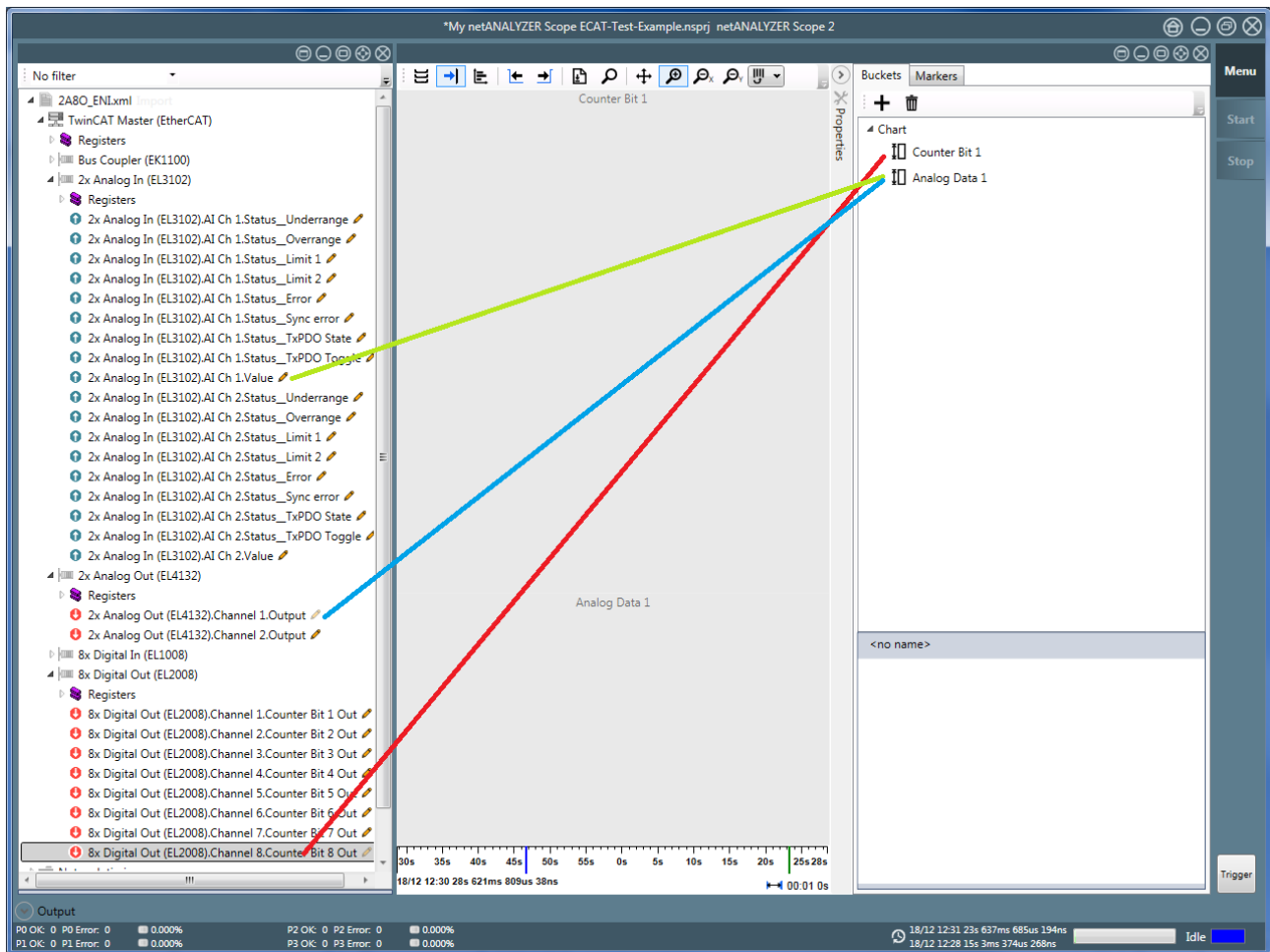

Figure 132: Display of items in the data recorder window

In the example, two buckets have been created:

- *Counter Bit 1*
- *Analog Data 1*

Counter Bit 8 of Channel 8 of 8x Digital Out device EL2008 is assigned to *Counter Bit 1* (red line).

The value of Channel 1 of device EL3102 (light blue line) and the output of Channel 1 of device EL4132 (green line) are assigned to *Analog Data 1* in this example.

After this assignment has taken place, the Chart View might look similar to this:

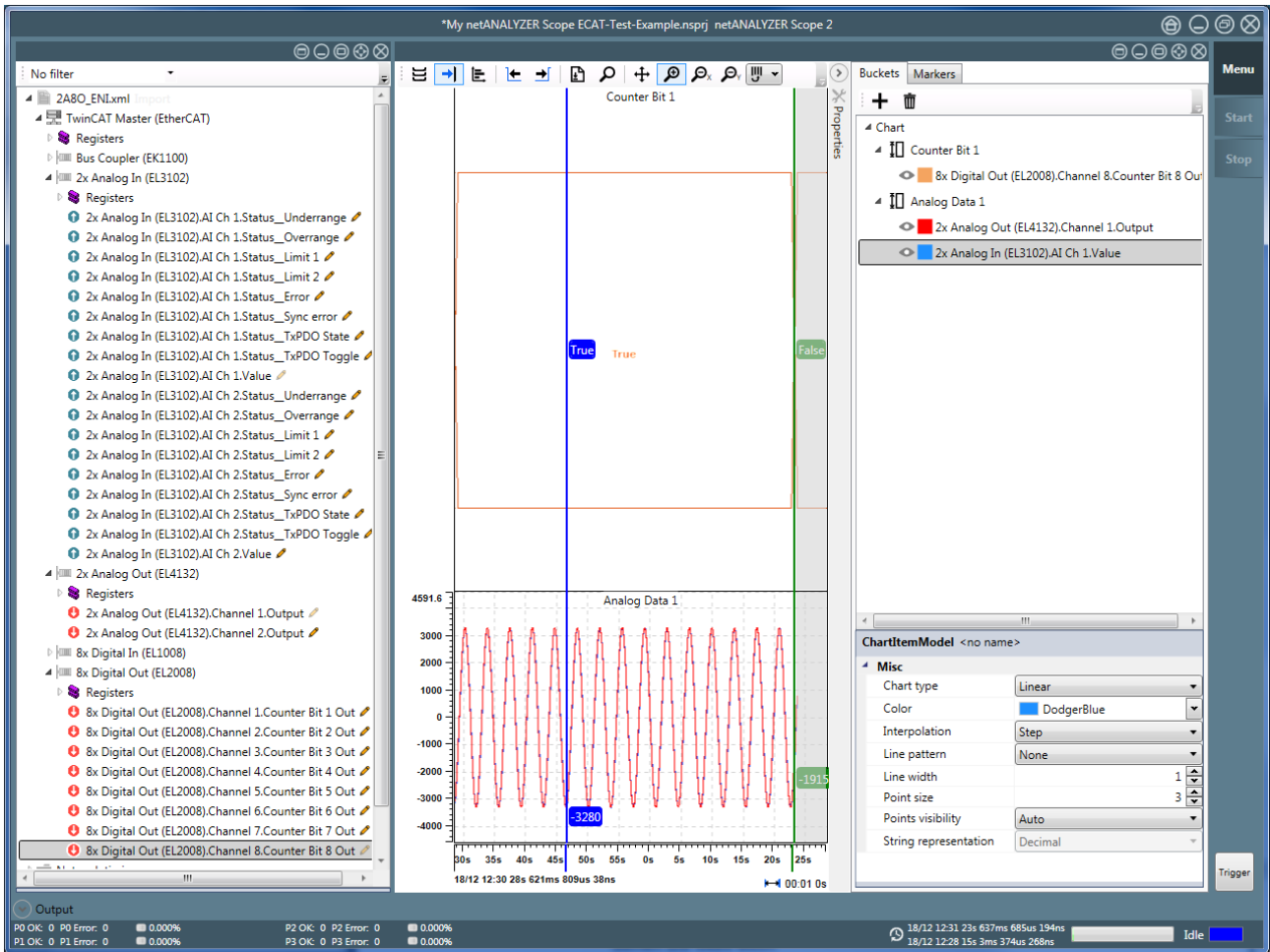

Figure 133: Chart View after the assignment

10.6.3 Controls in window bar

The window bar at the upper edge of the Chart View contains the following controls:















Control	Description
	Automatically adjust containers Using the control "Automatically adjust containers" in the title bar of the Chart View the signals are placed regularly on the screen.
	Snap to latest timestamp By clicking at this button, the cursor is set to the last recorded value, i.e. that with the latest timestamp.
	Enable histogram view Display a histogram at the right edge of the Live-Data View
	Snap to preceding value Go to the preceding value of the currently selected item using the currently selected marker.
	Snap to next value Go to the next value of the currently selected item using the currently selected marker.
	Snap to previous change Move currently selected marker to the preceding change of value of the currently selected item.
	Snap to next change Move currently selected marker to the next change of value of the currently selected item.
	Export Opens file export dialog for data export in to a *.CSV file. See <i>REPLACEME</i> [▶ page 174]. Export to *.CSV file below!
	Search Opens the search dialog. See Searching Variable Values below! See <i>Searching Variable Values</i> [▶ page 176] below.
	Move the chart in horizontal and vertical direction Allows moving the graph within the Live-Daten-Ansicht in all directions.. See <i>Move</i> [▶ page 192].
	Zoom to the marked area Displays a smaller data area more precisely. See <i>Zoom In</i> [▶ page 179].
	Zoom out horizontally Displays a larger data area less precisely (in direction of the x-axis). See <i>Zoom Out</i> [▶ page 179].
	Zoom out vertically Displays a larger data area less precisely (in direction of the y-axis) . See <i>Zoom Out</i> [▶ page 179].
	Timestamp.search Locates the cursor onto a specific timestamp. See <i>Going to a specific Timestamp</i> [▶ page 175] below!

Table 68: Controls in window bar in Chart View

10.6.3.1 Data export to *.CSV file

The button  opens the Export dialog. This enables exporting data from the Chart View to a *.CSV file, which, for instance, can be imported, displayed and processed further in spreadsheet software like Microsoft Excel®.

The Export dialog of the Chart View looks like:

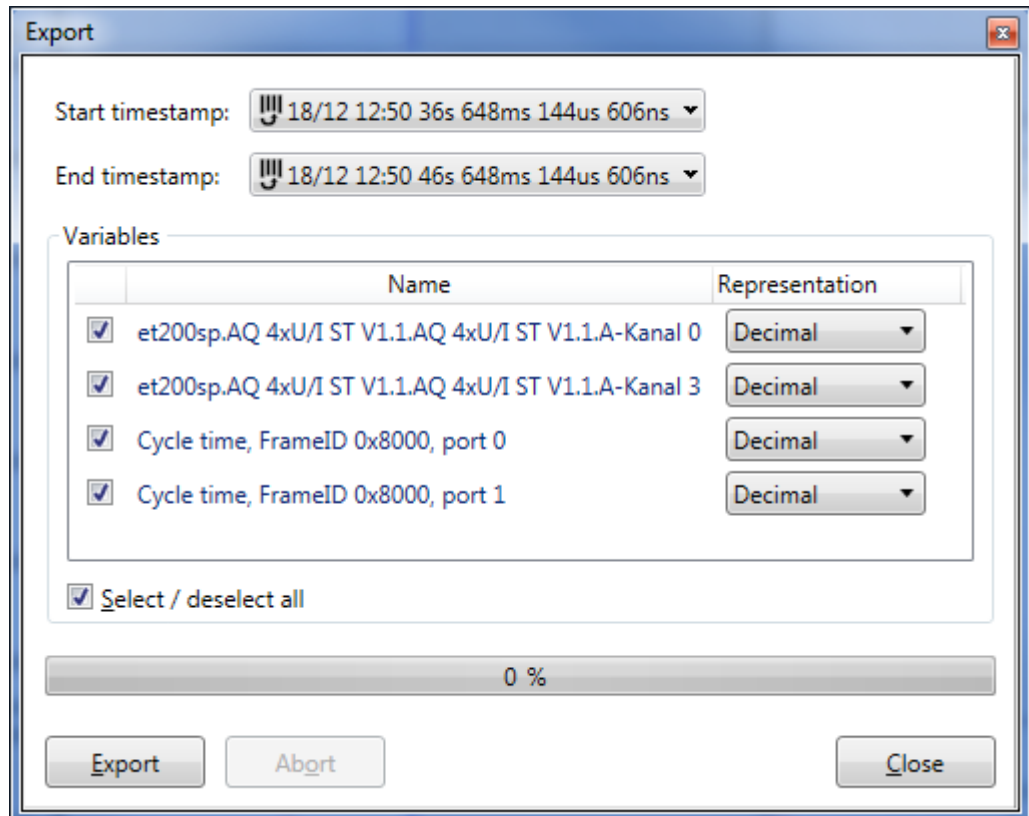

Figure 134: Export Dialog of the

The single elements of Export dialog have the following meaning:

Element of the export dialog	Meaning
Start timestamp	This is a control for timestamp input as described within the preceding subsection Going to a Cursor or Marker allowing to define the start time of the data material to be exported.
End timestamp	This is a control for timestamp input as described within the preceding subsection Going to a Cursor or Marker allowing to define the end time of the data material to be exported.
Path	The path to the *.CSV file, into which the data to be exported shall be written. Initially, this field has a red frame indicating incorrect input (as the field is empty), but the red frame disappears as soon as a correct input has been specified.
Browse	The button “Browse” opens a file selection dialog in order to easily select the storage location of the *.CSV file.
Variables	By checking the respective variable, creation of a column for this variable can be enforced within the *.CSV file.
Select/deselect all	Clicking at this button checks/releases all available variables simultaneously.
Sort ascending Sort descending	Using this button, the order of sorting can be defined to be ascending or descending for the data in the *.CSV file.

Element of the export dialog	Meaning
Export	Clicking at the button opens a selection dialog for the path to the *.CSV file. After choosing the path the export process is started and its progress will be displayed in percent by the progress bar display just above the button. If 100 % is reached, the *.CSV file is complete and available.
Abort	Clicking at this button will abort the data export.
Close	Clicking at this button will close the dialog.

Table 69: Elemente des Export-Dialogs und ihre Bedeutung:

10.6.3.2 Going to a specific timestamp

By clicking at the  button, you can specify a timestamp where to set the cursor to .

The timestamp can be specified by two ways:

1. Set the cursor to the time value of a previously defined marker. This can be accomplished using the selection box

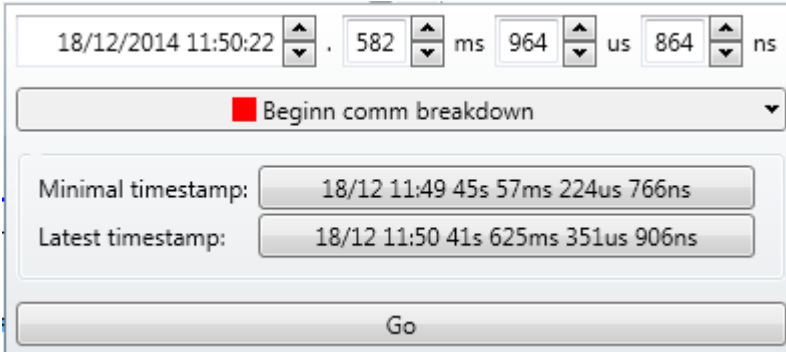

Figure 135: Timestamp Input Control with Marker

2. Enter date and time numerically (on seconds level) in DD.MM.YYYY hh:mm:ss format (left) and to enter the fractional part in groups of milliseconds, microseconds and nanoseconds each in nnn format (right). See figure below:

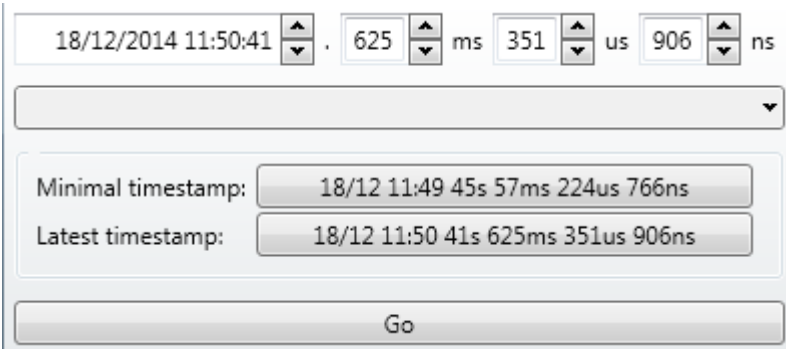



Figure 136: Timestamp Input Control

The minimum timestamp and the last timestamp are each displayed in the corresponding field.

10.6.3.3 Searching Variable Values

By clicking at the button , you can open the search dialog in order to search for occurrences of variables fulfilling certain conditions. You can specify a variable, and a search condition to be fulfilled.

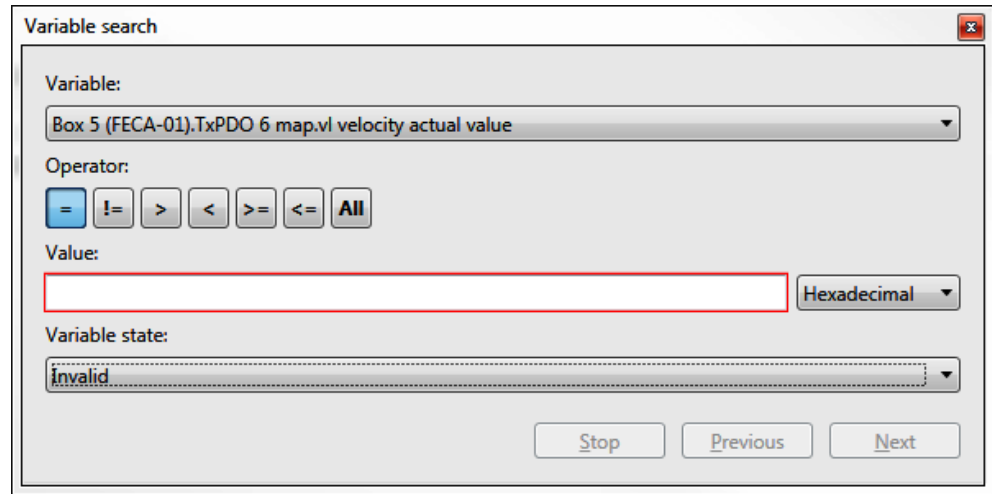

Figure 137: Search Dialog

The search condition to be fulfilled is chosen by selecting a comparison operator and specifying a comparison value. The search dialog consists of the following elements:

Selection List “Variable”

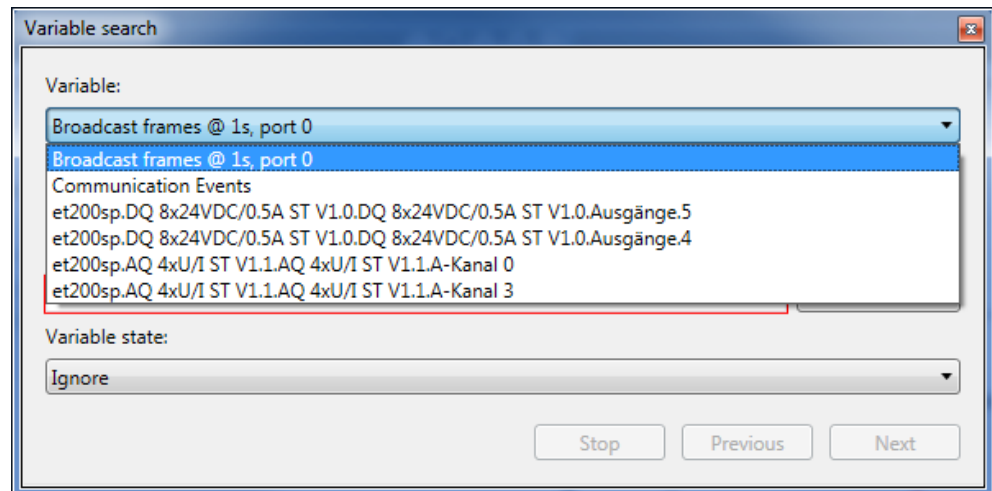

Figure 138: Selection List “Variable” (Example Contents)

This selection list displays all available variables.

Operator Buttons



Figure 139: Operator Buttons

The operator buttons

= (equal),
 != (not equal),
 > (greater than),
 < (less than),
 >= (greater or equal),
 <= (less or equal)

can be used to specify the filter condition to be met by the variable.

The button **All** means that there is no comparison : If this operator is activated, the search dialog simply will find the previous or next timestamp with an arbitrary value of the chosen variable.

The default operator is “=”. Depending on the current situation, not all of these choices will be offered.

Value field



Figure 140: Value Field

Here you can specify the value against which the variable will be tested within the condition. If the value field's frame is colored red, either there is no input or the input is invalid. In this case you have to specify a correct value for the according data type.

Selection list for variable state

Using this list, the search process can be restricted to variables having a specific state regarding their validity. The following options are available.

Variable state	Meaning
<i>Invalid</i>	Only find variable with state <i>Invalid</i>
<i>Valid</i>	Only find variable with state <i>Valid</i>
<i>Ignore</i>	No restriction concerning state of variable

Table 70: Selection options for variable state

Default option is *Ignore*

Selection list for datatype

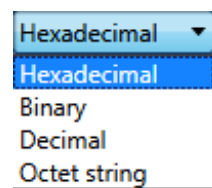

Figure 141: Selection list for data type

Here you choose the data type for the variable in the *Value* field. The following data types are supported:

- Decimal
- Hexadecimal
- Binary
- Boolean
- ASCII string

- Octet string
- Unicode string

Depending on the variable, not all of these choices may be available.

Stop button

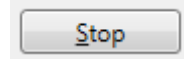

You can stop the search and close the search dialog box..

Previous and Next buttons

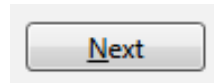
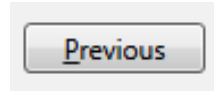

You can then navigate through these occurrences by clicking at the *Previous* and *Next* buttons. If no result have been found, the text “No result” is displayed at the lower edge of the search dialog.

10.6.3.4 Histogram

The icon offers the possibility to switch between the usual Chart View and a Chart View with additional histogram display.

The Chart View with additional histogram display looks as follows:

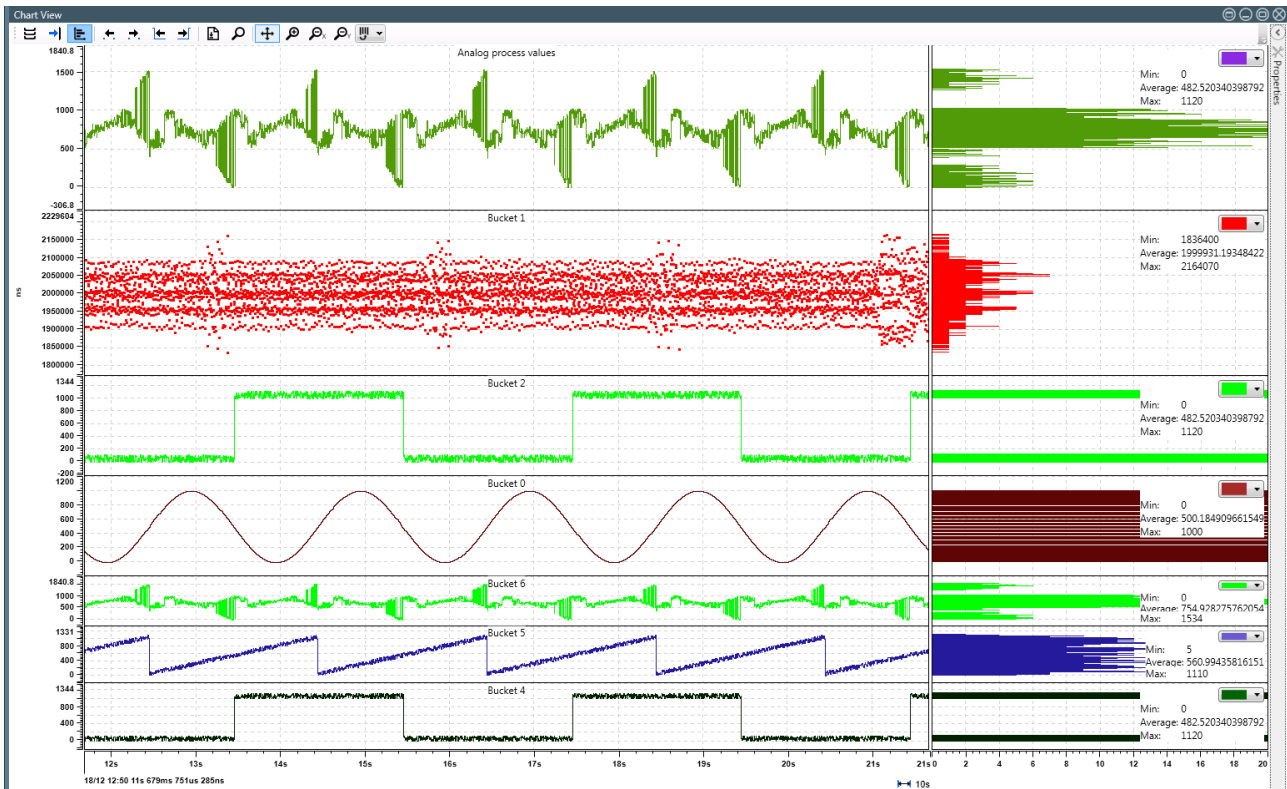

Figure 142: Chart View with additional histogram display

The histogram display always relates to the time interval visible within the chart.

The histogram is displayed right of a double separation line. It illustrates the corresponding value on the y-axis. Minimum, average and maximum values are displayed in the upper right corner of each histogram.

10.6.4 Scaling of time axis and value axis/Scroll bar



Scaling is done via the three zoom icons in the icon bar at the top of the Chart View window. See subsequent sections *Zoom In* [▶ page 179] and *Zoom Out* [▶ page 179].

10.6.4.1 Zoom In

1. In order to zoom in (i.e. to scale the display area so that only a part of the current display area is shown, but in more detail):
 - Click at the zoom-in-symbol  in of the display area whose scaling should be adapted.
 - Click at the upper left corner of the area to be displayed in more detail and keep the mouse button pressed. Release the mouse button at the lower right corner of the area to be displayed in more detail.
 - ⇒ The display area will immediately be displayed in more detail according to your choice.

10.6.4.2 Zoom Out

Zooming out can be done separately for the direction of the time axis (x-axis) and the value axis (y-axis).

1. In order to scale the time axis of the display area so that a larger area is displayed (in less detail):
 - Click at the zoom-out-symbol  of the display area whose scaling should be adapted.
 - ⇒ The scale of the display area of the chosen item will be adapted accordingly.
2. In order to scale the value axis of the display area so that a larger area is displayed: (in less detail)
 - Click at the zoom-out-symbol  of the display area whose scaling should be adapted.
 - ⇒ The scale of the display area of the chosen item will be adapted accordingly.

10.6.4.3 Zooming with the mouse wheel

Zooming can also be done using the mouse wheel.

- If the mouse wheel is turned when the mouse cursor is on an axis, the respective axis is zoomed.
- If the mouse wheel is turned when the mouse cursor is in the display area: the time axis is zoomed.

10.6.5 Configuring the display area for recorded data

Various settings allow to individually configure the appearance of the display to your needs. These can be performed via some icons located near the upper right corner of the display area of each item.

In the following the meaning of the various icons is explained.

10.6.5.1 Working with Buckets

A bucket is an area in the screen which is designated to displaysome data. You can do the following with buckets:

Adding a new bucket

1. In order to add a new bucket to the Chart View window:
 - Open the Markers register in the *Buckets/Markers* area of the Chart View window
 - The list of currently defined buckets is display below.
 - Click at the + sign Icon in the Buckets/Markers area of the Chart View window.
 - ⇒ A new bucket is created and displayed in the list of buckets.

You might wish to assign a name to this bucket.

Assigning a name to a bucket

2. In order to assign a name to a bucket:
 - Specify a name for the bucket to rename in the lower part of the Buckets/Markers area of the Chart View window in the row *Name* of the table titled **Misc**. If no name has been specified, the entry to change is filled with *No name*.
 - ⇒ The new name for the bucket is used.

You might also wish to change the color of the newly created bucket.

Removing a bucket

3. In order to remove a bucket from the Chart View window
 - Select the bucket you want to remove within the list in the Buckets/Markers area of the Chart View window.
 - Click at the waste basket symbol within the Buckets/Markers area of the Chart View window window .

The according bucket disappears both from the display and the list.

10.6.5.2 Auto-scale and hide buttons

Within the Buckets/Markers area of the Chart View , buttons provide auto-scale and hide functionality as follows:





Button (active)	Button (inactive)	Meaning	Functionality
		Auto-scale	If active, the value axis of the diagram corresponding to the chosen item to which the button belongs is newly scaled for optimum display within the available space.
		Hide/unhide	Clicking this button once (in active state) makes the diagram corresponding to the chosen item to which the button belongs invisible. Clicking it for a second time displays the diagram again.

Table 71: Auto-scale and hide buttons

10.6.5.3 Configuring buckets

Some settings can be configured via the Buckets/Markers area of the Chart View window:

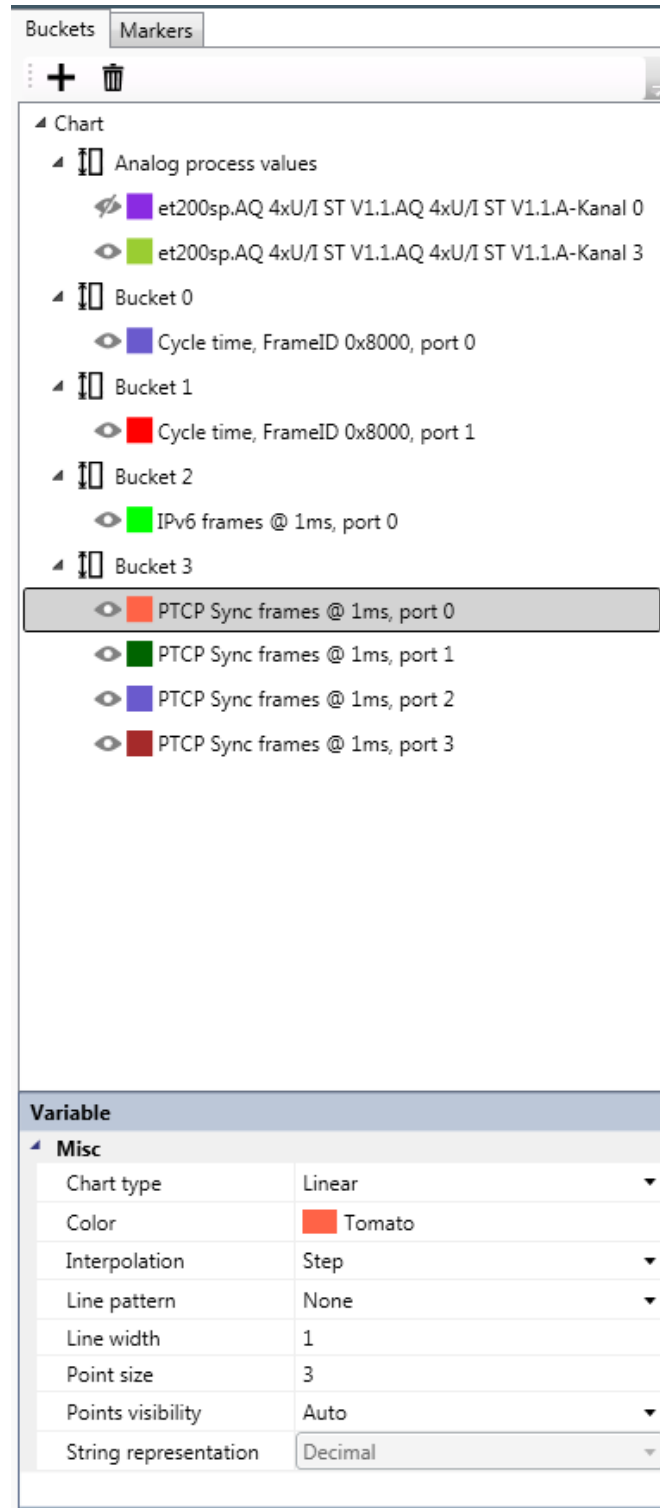

Figure 143: Buckets/Markers area of the Chart View window

The following options are provided within the Buckets/Markers area of the Chart View window:

Option *Chart type*

You can switch between the following three chart types:

Chart type	Meaning
Linear	The data points are connected by a line.
Literal	The labeling at the value axis of the display area is present. Horizontal and vertical auxiliary lines are displayed, too.
Event	Value changes are displayed as single events, where the value itself is displayed as text beside the event.

Table 72: Chart types

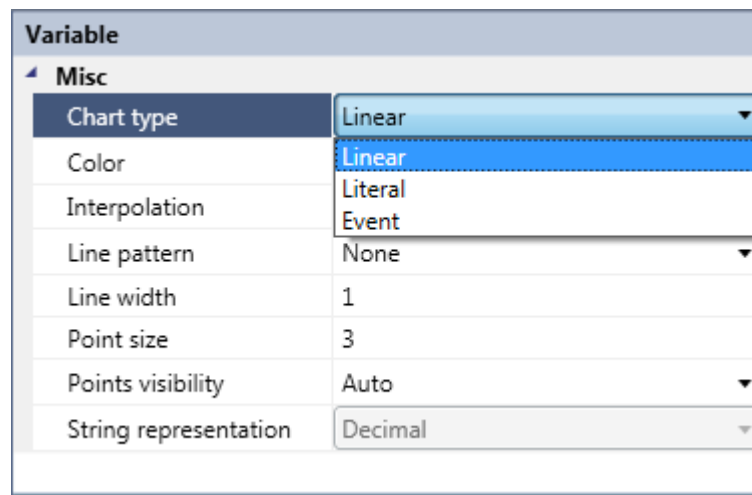

Figure 144: Chart type

Option *Points visibility*

The *Points visibility* option allows you to switch whether the value points are displayed or not.

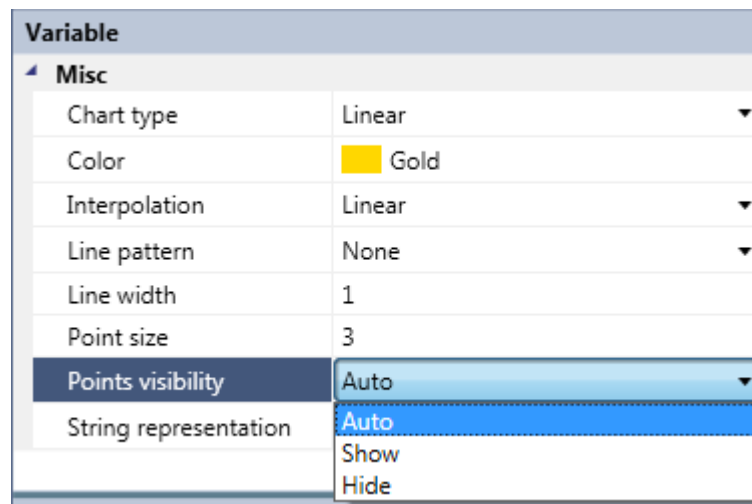

Figure 145: Option *Points visibility*

The permitted values of the *Points visibility* option *Auto*, *Hide* and *Show*.

Option	Meaning
<i>Auto</i>	The system decides by itself, whether the data points are shown and marked, or not. Each data point corresponds to a time when data is captured, for process variables this represents the communication cycle time. (This is the default setting of the Value Points option.)

Option	Meaning
Hide	The value points recorded by netANALYZER Scope are hidden, i.e. invisible.
Show	The value points recorded by netANALYZER Scope are shown and marked. Enabling the <i>Literal</i> option (On) will set the <i>Points visibility</i> option to <i>Hide</i> .

Table 73: Display Points option

Option *Points visibility*



Note:

Diagram type *Literal* sets the *Points visibility* option to *Hide*.

Option *Interpolation*

The *Interpolation* option allows you to choose the kind of interpolation used in the lines connecting the measured data points.

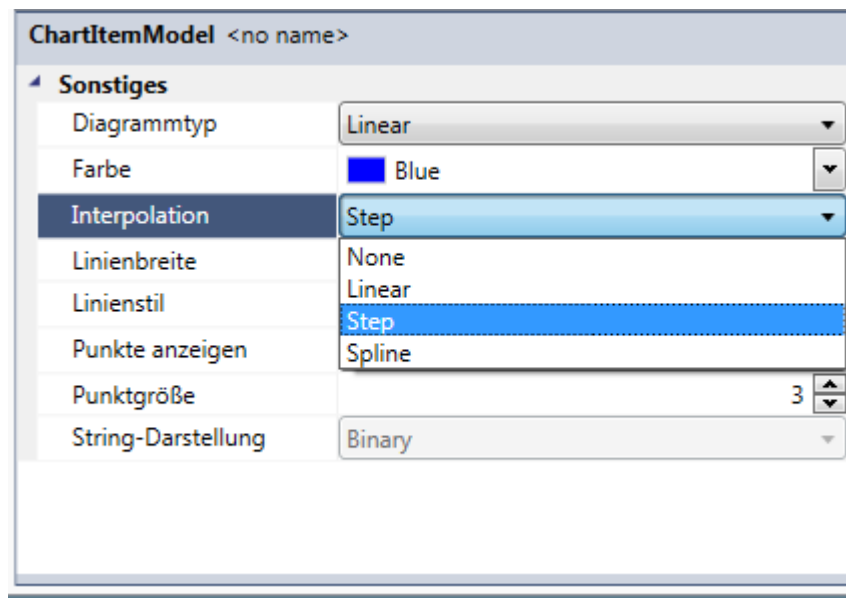

Figure 146: Option *Interpolation*

The available kinds of interpolation to be applied here are explained in the subsequent table:

Option	Meaning/ Consequences
Interpolation 	No interpolation is performed, only the data points themselves are displayed.. This is the default setting of the <i>Interpolation</i> option.
Interpolation 	A linear interpolation is performed to generate a graph connecting the individual data points.
Interpolation 	A step graph connecting the individual data points is generated.
Interpolation 	A spline interpolation is performed to generate a graph connecting the individual data points.

Table 74: *ChartItemModel* subwindow: Option *Interpolation*

Option *Linewidth*

The option *Linewidth* allows you to adjust the width of the line connecting the collected data points.

Variable	
Misc	
Chart type	Linear ▼
Color	 Gold
Interpolation	Linear ▼
Line pattern	None ▼
Line width	4 ▲▼
Point size	3
Points visibility	Auto ▼
String representation	Decimal ▼

Figure 147: Option *Linewidth*

You can specify a positive integer value here. The value 0 is not allowed.

You can type in the value directly into the field. Incorrect input here will cause a red frame around the input field to appear! Alternatively, you can specify a value by incrementing the value with the Arrow up symbol or decrementing it with the Arrow down symbol (both symbols are at the right edge of the table).

Option *Line pattern*

The option *Line pattern* allows you to adjust the style of the line connecting the collected data points.

Variable	
Misc	
Chart type	Linear ▼
Color	 Gold
Interpolation	Linear ▼
Line pattern	None ▼
Line width	None
Point size	Dotted
Points visibility	Dash (Long)
String representation	Dash (Medium)
	Dash (Short)
	Dash-Dot
	Dash-Dot-Dot

Figure 148: Option *Line pattern*

The following options are available:

- None
- Dotted
- Dash (Long)
- Dash (Medium)
- Dash (Short)
- Dash-Dot
- Dash-Dot-Dot

Option *Point size*

The option *Point size* allows you to adjust the size of the graphical representation of the collected data points

Variable	
Misc	
Chart type	Linear ▼
Color	 Gold
Interpolation	Linear ▼
Line pattern	None ▼
Line width	4
Point size	3 ▲▼
Points visibility	Auto ▼
String representation	Decimal ▼

Figure 149: Option *Point size*

You can specify a positive integer value here. The value 0 is not allowed.

You can type in the value directly into the field. Incorrect input here will cause a red frame around the input field to appear! Alternatively, you can specify a value by incrementing the value with the Arrow up symbol or decrementing it with the Arrow down symbol (both symbols are at the right edge of the table).

Option *String representation*

The *String representation* option allows you to adapt the representation of the data to the data type of the measured data points.

ChartItemModel <no name>	
Sonstiges	
Diagrammtyp	Event ▼
Farbe	 Fuchsia ▼
Interpolation	Step ▼
Linienbreite	1 ▲▼
Linienstil	None ▼
Punkte anzeigen	Auto ▼
Punktgröße	10 ▲▼
String-Darstellung	ASCII string ▼
	ASCII string
	Octet string

Figure 150: Option *String representation*

The available representations to be applied here are explained in the subsequent table:

Option	Meaning/ Consequences
Representation: Hexadecimal ▾	The data are displayed in hexadecimal representation.
Representation: Decimal ▾	The data are displayed in decimal representation. This is the default setting of the <i>Representation</i> option.
Representation: Boolean ▾	The data are displayed in Boolean representation.
Representation: Binary ▾	The data are displayed in binary representation.
Representation: Octet string ▾	The data are displayed in Octet String representation. (Octet String = Byte String)
Representation: ASCII string ▾	The data are displayed in ASCII String representation.
Representation: Unicode string ▾	The data are displayed in Unicode String representation.

Table 75: Representation of String Values



Note:

Only options applicable within the current context are displayed.

10.6.5.4 Working with the Cursor

The cursor is a tag signifying the current position on the time axis, usually displayed in the Chart View as a blue vertical line. There is only one cursor at maximum. If necessary, the cursor can be moved to another position on the time axis.

In order to set the cursor to a specific position on the time axis:

Within the Chart View, point with the mouse cursor to the time you want to set the cursor to.

Double click there.

The cursor is set to the selected position. Furthermore, if the Markers register card of the Buffers/Markers area of the Chart View is visible, then the Cursor will be listed in the list below “*Markers*”.

There are two methods for moving the mouse cursor to another time within the Chart View:

With drag&drop

In order to move the cursor to another position on the time axis of the Chart View, use drag & drop as follows:

Move the mouse cursor at the position of the cursor.

The mouse cursor is transformed to a double arrow symbol.

Drag it to its new position and drop it there using the **left** mouse button.

The cursor will now appear at its new position.

With double click

In order to move the cursor to another position on the time axis of the Chart View

Double click to the time you want to set the cursor to.

The cursor is set to the selected position.

The first method might work more precisely, the second might be quicker.

10.6.5.5 Working with Markers

A marker is a tag signifying a position on the time axis of special interest. Markers are synchronized over multiple windows in netANALYZER Scope.

Multiple markers are allowed to be set as it is possible to add a new marker, see “Adding a new Marker” below. An existing marker can be set to a new position, see “Setting a Marker”. It is also possible to remove an existing marker, see “Removing a Marker” below.

Adding a new marker

In order to add a new marker to the Chart View:

- Open the Markers register in the Buckets/Markers area of the Chart View.
- The list of currently defined markers is display below.
- Click at the + sign Icon in the Buckets/Markers area of the Chart View.
- ⇒ A new marker is created and displayed in the list of markers.

You might wish to assign a name to this marker.

Assigning a name to a marker

In order to assign a name to a marker:

- Specify a name for the marker to rename in the lower part of the Buckets/Markers area of the Chart View in the row *Name* of the table titled **Misc**. If no name has been specified, the entry to change is filled with `No name`.

⇒ The new name for the marker is used.

You might also wish to change the color of the newly created marker.

Changing the color of a marker

In order to change a marker's color:

- Open the color selection box by opening the selection list right o *Color*. in the lower part of the Buckets/Markers area of the Chart View in the row *Color* of the table titled **Misc**.
- Select the color of the marker using the color selection box.



Figure 151: Color Selection

⇒ The color of the marker is changed accordingly.

Color Selection

The color selection box offers two different modes of operation, namely

- Standard mode
- Advanced mode

In standard mode, you may select between a variety of predefined colors which are proposed by netANALYZER Scope additionally to the standard colors. Just click at the desired graph color.

The figure below shows the color selection box in standard mode.

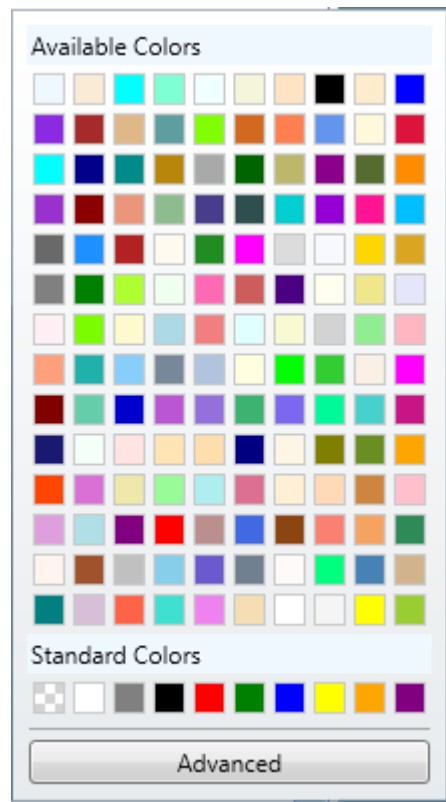

Figure 152: Color Selection Box in Standard Mode

Alternatively, you can also select the graph color to be applied by specifying the red (R), green (G) and blue (B) components of the color and the saturation (A). This is accomplished by the advanced mode. Color Selection Box in Advanced Mode below shows the advanced mode color selection box.

Switching to advanced mode

Switching to advanced mode

1. In order to switch to the advanced mode:
 - Within the standard mode color selection box, click at the *Advanced* button, see the figure above.
 - ⇒ The display of the color selection box switches from standard mode to advanced mode.

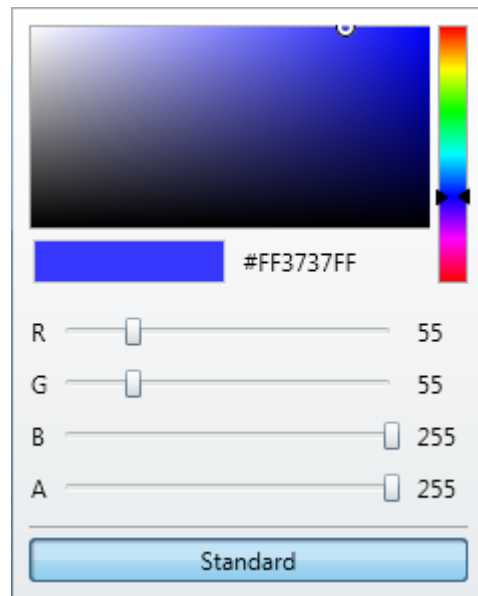

Figure 153: Color Selection Box in Advanced Mode

Specify a color in Advanced Mode

You can set the color by moving the color cursor (marked by a circle) in the multi-colored field. When moving the color cursor, the following happens:

The selected color is shown with a white frame just below the text “Color” in the grey box at the top of the color selection box. If you would leave the color selection box now, this color would be used for the graph.

The color of small rectangle just below the multi-colored rectangle changes to the color at the position of the cursor.

The hexadecimal representation of the color is displayed right beside the small rectangle.

Switching to standard mode

Switching to standard mode

2. In order to switch back to the Standard Mode
 - Click at the *Standard* button within the advanced mode color selection box.

The display of the color selection box switches from advanced mode to standard mode.

Setting a marker to the center

3. In order to set a new marker to the center of the Chart View:
 - Open the Markers register in the Buckets/Markers area of the Chart View.
 - ⇒ The list of currently defined markers is displayed below.
 - Click at the thin grey cross sign right of the waste basket symbol in the Buckets/Markers area of the Chart View.
 - ⇒ The marker is centered.

Removing a marker

4. In order to remove a marker from the Chart View:
 - Select the marker you want to remove within the list in the Buckets/Markers area of the Chart View.
 - Click at the waste basket symbol within the Buckets/Markers area of the Chart View.
 - ⇒ The according marker disappears both from the display and the list.

10.6.5.6 Move

1. In order to move the display area of one item up or down:
 - Drag the move symbol  of the display area to be moved to the place where the area should be displayed in future, and drop it there.
 - ⇒ The display area of the chosen item will appear at the new place you have dragged it to.

10.6.6 Performance considerations

The following factors may have an influence on the performance of the Chart View.

- when timing analysis is used and the interval between the timing samples is very wide, as always the next neighbor sample must be queried internally. For optimum performance timing analysis should be only be made on samples which are nearby.
- a wide zoom range is used, use narrow zoom ranges whenever possible.
- a big amount of variables is used, drag only a small amount of variables to the chart when your systems memory is low.

10.7 Working with the notepad view

A notepad offers you the possibility to store additional text information concerning your measurement or project.

10.7.1 Open a new notepad view

1. In order to open an item list window:
 - Click at the *Menu* button in the right side menu.
 - Click at the square button *Notepad*
 - ⇒ A notepad window is displayed within the netANALYZER Scope window. It should look like this:

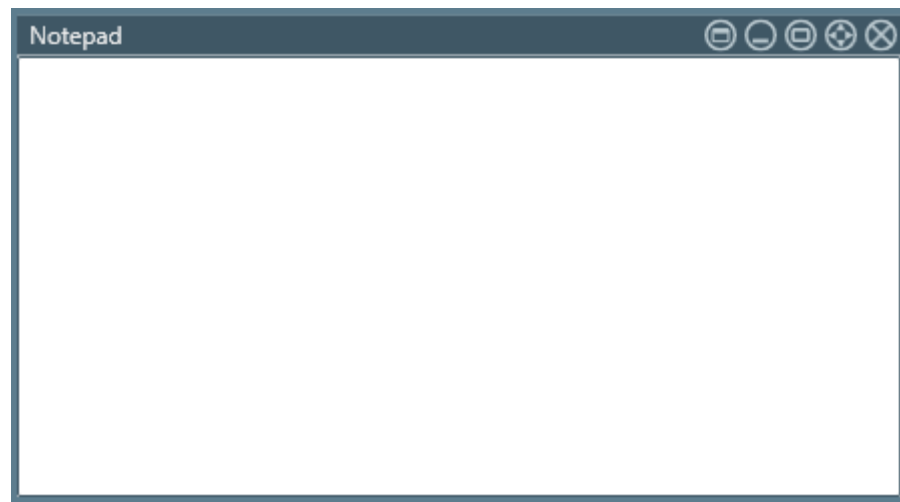

Figure 154: Notepad window

If you type in a text, it will be displayed within the notepad window. If you mark that text and right-click on it, the context menu will open:

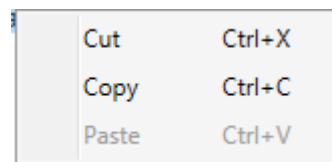

Figure 155: Context menu of notepad view

Depending on the current context, it offers the functions

- Cut
- Copy
- Paste

Clicking at the cross icon at the right upper corner of the view causes the notepad view to close the window and to discard the input text. However, before that happens, a safety message warning against possible data loss appears. It looks like:

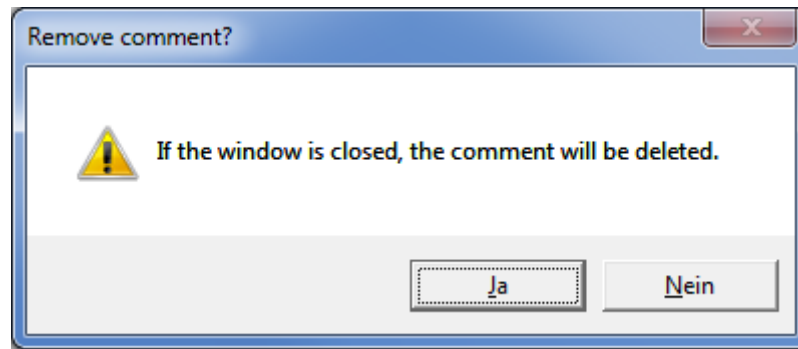

Figure 156: Safety message "Remove comment?"

10.8 Trigger view

In order to define conditions for stopping recordings of Ethernet frames, netANALYZER Scope allows to define one or multiple trigger events.

This gives you the opportunity to find the interesting information you are looking for much easier as it will be located relatively short before the end of the recording if the trigger definition has been done appropriately. Even complicated situations should easily be reproduced by an appropriate definition of trigger conditions.

The basic concept of triggering is to define conditions causing the triggering event(s) depending on variables and constants.

Variables represent for instance the signals or EtherCAT registers to be supervised. Constants may be needed for the purpose of comparison.

This triggering concept is reflected by the structure of the trigger view in netANALYZER Scope.

On the left, there is a sources area representing variables and constants and a function block area containing the possibilities to express the logic of the triggering conditions to be defined. Within a graphical editor the trigger logic can be designed from these items.

Using drag & drop, you can design the trigger logic using the previously defined variables, constants and function blocks. Typically, the variables representing your signals and constants needed as comparison values will be located at the left, the function blocks representing the trigger logic will be located in the center and the triggers themselves will be located at the right side of the working area of the graphical editor.

10.8.1 Structure of the trigger view window

The window of the trigger view looks as follows:

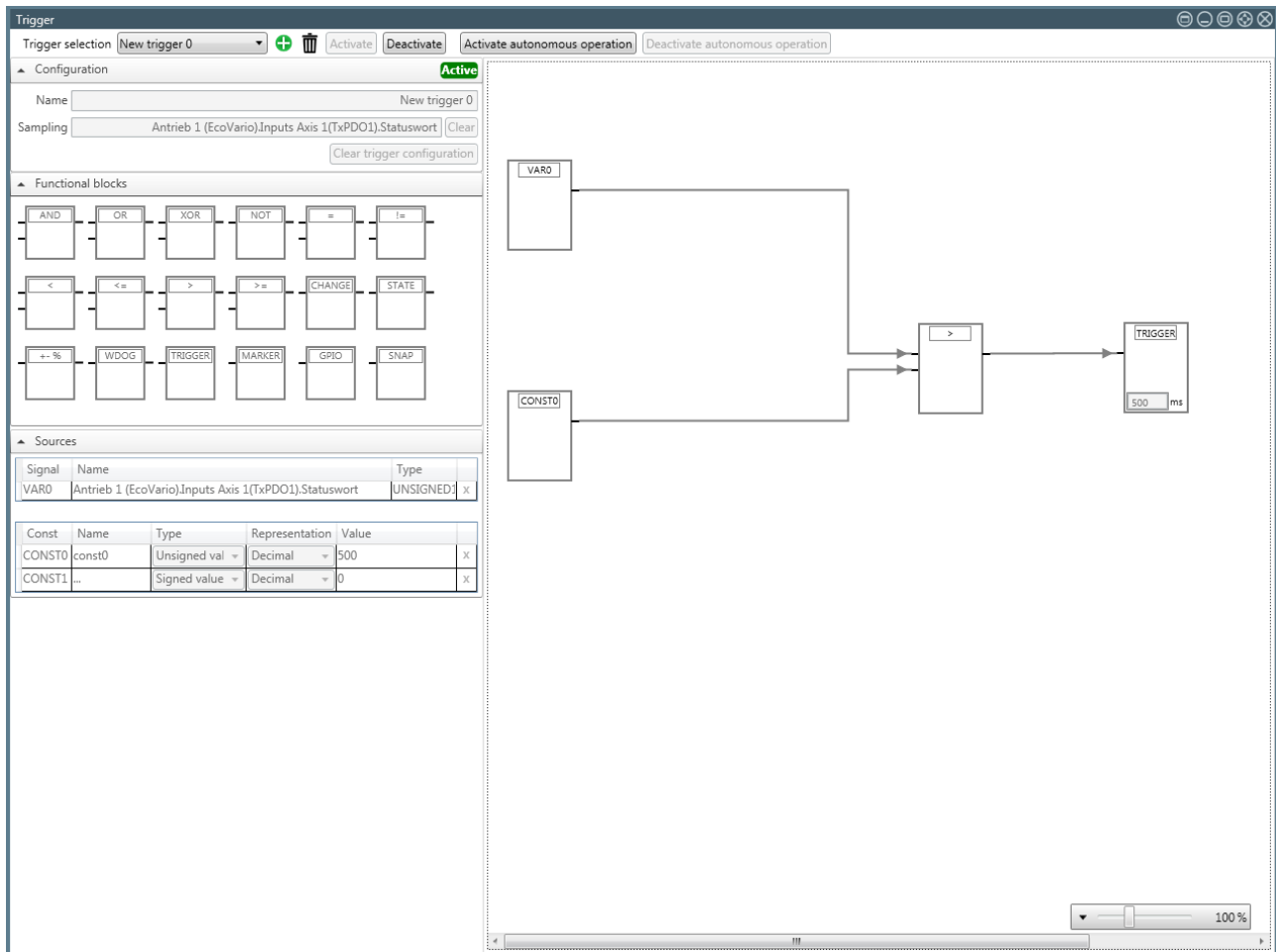

Figure 157: Trigger view (Example)

It consists of the following parts and areas:

1. the window bar

The window bar is located at the upper edge of the trigger view window. It contains the basic controls of the trigger view window. See *Window bar of trigger window* [▶ page 196].

2. the configuration area

The configuration area is located at the upper part of the left edge of the trigger view window. There new configurations can be created and assigned with a name. Also the sampling time can be defined there. See *Configuration area* [▶ page 200].

3. the function blocks area

The function blocks area is located at the center part of the left edge of the trigger view window. Here you can select function blocks to be used within the graphical editor area. See *Functional blocks area* [▶ page 208].

4. the source area

The source area is located at the lower part of the left edge of the trigger view window. Within the source area you can define signals (variables) and constants to be used within the graphical editor area. See *Sources area* [▶ page 202].

5. the graphical editor area

The graphical editor area is located within the right part of the trigger view window. There you can drop objects such as signals, constants and function blocks which you drag in from outside, you can connect these according to your needs and adjust the settings of these objects. See *The graphical editor area* [▶ page 201].

10.8.2 Window bar of trigger window

The window bar of the trigger view looks as follows:



Figure 158: Window bar

It contains the basic controls of the trigger view window.

Control	Function
New trigger 0	Selection list
+	Plus symbol (Adding a new configuration)
🗑️	Trashcan symbol: Removing a trigger-Definition
Activate	Activating the trigger in standard operation
Deactivate	Deactivating the trigger in standard operation
Activate autonomous operation	Activating the trigger in autonomous operation
Deactivate autonomous operation	Deactivating the trigger in autonomous operation

Table 76: Controls within window bar of trigger view

The trigger selection list

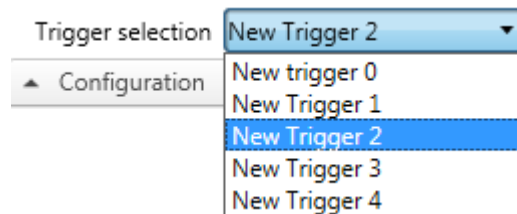

Figure 159: Trigger selection list (expanded)

The trigger selection list enables you to switch between multiple trigger definitions, which can be edited within the trigger view. When switching from one trigger definition to another, the following occurs:

1. In the graphic editor, the representation of the trigger logic is updated.
2. The representation of the configuration area, especially the chosen variable for the sampling time, is updated.

3. The signal table and the constants table within the source area are updated.

Add a new trigger definition to the trigger selection list

In order to create a new trigger definition to be presented within the trigger selection list:

- Click at button  within the window bar at the upper edge of the trigger view window.
- ⇒ An empty, new workspace of the graphic editor without any trigger logic appears. A new name is proposed for the trigger definition and displayed in the field "Name" of the configuration area.
- If you intend to change the name of the trigger definition, you can do that in the field "Name" of the configuration area.
- Now select the variable, to which the sampling time relates, see section *Configuration area* [▶ page 200].
- ⇒ Now you can continue with the design of the trigger logic for this definition, see section *The graphical editor area* [▶ page 201].

Delete a trigger definition

In order to delete a trigger definition



- Click at the button with the trashcan symbol  within the upper window bar of the trigger view.
- ⇒ The selected trigger definition is **immediately** deleted. **No safety request is issued.** The topmost trigger definition of the trigger selection list is displayed.

Activate a new trigger

If you designed the logic for a trigger definition within the graphic editor, you can now activate it.

This means that the defined trigger conditions are supervised continuously during data acquisition and the selected trigger behavior is executed on occurrence of a defined trigger condition.

In order to activate a new trigger definition for standard operation:

- Click at button  within the window bar at the upper edge of the trigger view window.
- ⇒ If the trigger definition within the graphic editor is correct, the small green symbol  is displayed in the upper right corner of the configuration area. This means, that the trigger definition is active (in standard mode).
The configuration area, the source area with the signal table and the constants table, the functions block area and the workspace of the graphic editor are no longer editable.
- ⇒ If an error message similar to the following one appears anyway containing *Trigger configuration is not valid* as its first line:

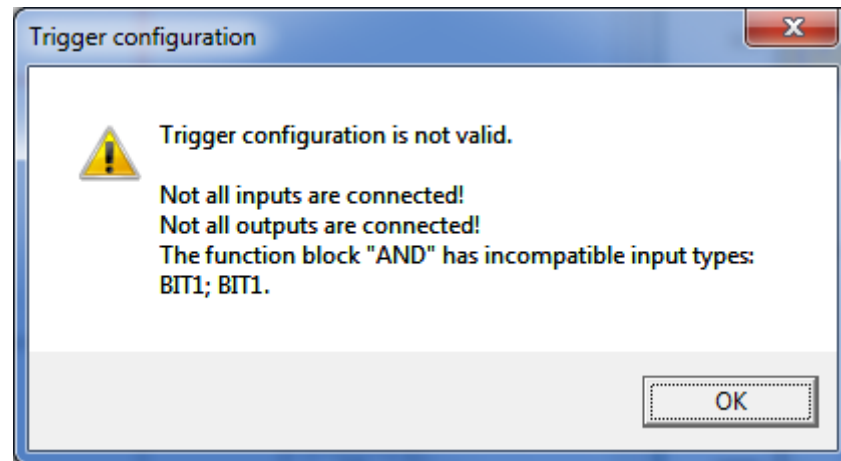

Figure 160: Error message *Trigger configuration is not valid*



Note:

You can find more information concerning the error message *Trigger configuration is not valid* and possible remedies against it in subsection *Window bar of trigger window* [▶ page 199].

Deactivate an active trigger

If you designed the logic for a trigger definition within the graphic editor and then activated it, you can now deactivate it. In order to deactivate an already active trigger definition:

- Click at button **Deactivate** within the window bar at the upper edge of the trigger view window.
- ⇒ The currently active trigger is deactivated.
- ⇒ The small green symbol **Active** disappears at the upper right edge of the configuration area. The configuration area, the source area with the signal table and the constants table, the functions block area and the workspace of the graphic editor are now editable again .

Activate a trigger for autonomous operation

If you designed the logic for a trigger definition within the graphic editor, you can now activate it for autonomous operation as follows.

In order to activate a new trigger for autonomous operation:

- Click at button **Activate autonomous operation** within the window bar at the upper edge of the trigger view window.
- ⇒ If the trigger definition within the graphic editor is correct, the small green symbol **Autonomous operation active** is displayed in the upper right corner of the configuration area. This means, that the trigger is active in autonomous operation mode.
The configuration area, the source area with the signal table and the constants table, the functions block area and the workspace of the graphic editor are no longer editable.
- ⇒ However, if a dialog box containing the error message *Trigger configuration invalid* appears, then correct the trigger definition and try again to activate the trigger.

**Note:**

You can find more information concerning the error message *Trigger configuration is not valid* and possible remedies against it in subsection *Window bar of trigger window* [▶ page 199].

Deactivate an active trigger in autonomous operation

If you created a trigger definition within the graphic editor and activated it then for autonomous operation, you can deactivate this trigger definition again as follows. In order to deactivate an active trigger definition for autonomous operation:

- Click at button **Deactivate autonomous operation** within the window bar at the upper edge of the trigger view window.
- ⇒ The currently active trigger definition for autonomous mode is deactivated.
- ⇒ The small green symbol **Autonomous operation active** disappears at the upper right edge of the configuration area. The configuration area, the source area with the signal table and the constants table, the functions block area and the workspace of the graphic editor are now editable again.

Error message" Trigger configuration is not valid"

In the dialog box, the cause for the error message is specified. The subsequent table explains the possible causes and proposes suitable remedies.

Message text	Remedy
Not all inputs are connected!	Connect all inputs!
Not all outputs are connected!	Connect all outputs!
No variable exists in the configuration!	There must be at least one variable within the configuration. Add a variable to your trigger definition.
The function block X has incompatible input types: Y, Z	When using function blocks for logical operations such as comparisons, take care of all compared values having the same type and check the type definitions within the signal and the constants table for correctness.. X is the name of the respective function block Y and Z are different datatypes at the inputs of this function block.
GPIO X is not configured as output. Configure GPIO X as output to use it in a trigger block.	If you intend to use GPIO in conjunction with a trigger block, you have to configure it as output. X is an integer value between 0 and 3 specifying the GPIO port to be used.
Only in standard operation mode:	
Snapshot blocks are currently only allowed in autonomous operation mode.	Do not use snapshot blocks in standard operation mode. Use the trigger block instead.
Only in autonomous operation mode:	
In the autonomous operation mode, the only allowed output blocks are the snapshot block and the GPIO block.	Only use the snapshot block or the GPIO block as output block in autonomous mode.

Table 77: Error message "Trigger configuration is not valid" - Possible causes and suitable remedies (in autonomous operation mode)

10.8.3 Configuration area

In its initial state, the configuration area looks as follows:

Figure 161: Configuration area (Original state)

In the field „Name“ you can specify or change the name identifying the currently displayed trigger definition . The default name is `New Trigger`, plus a number which is incremented by 1 with every new trigger definition.

Specify variable for sampling time

If a variable is chosen to define the sampling time, the trigger condition is always evaluated at the time, at which the value of this variable is updated. The values of all input variables for the trigger at this particular time are taken into account in the calculation.

In order to define the sampling time using a variable, proceed as follows:

- Drag the desired variable (keeping the left mouse button pressed) from the element list to the field "Sampling" within the configuration area (see figure) and drop it there (release the mouse button there).

Figure 162: Field "Sampling"

- ⇒ The representation of the configuration area changes and the selected variable is displayed in the field "Sampling".

Figure 163: Configuration area with selected sampling time

Delete variable for sampling time

In order to delete the variable for sampling time:

- Click at the button right of the variable name in the configuration area.
- ⇒ Thus the trigger is evaluated at each single change of value of an arbitrary input variable.
- ⇒ The variable name is removed from the display and the field "Sampling" is displayed in its original state.

Delete current trigger definition

In order to completely delete the current trigger definition including the entry in the trigger selection list and the trigger logic:

- Click at the button in the configuration area.
- A safety request issues a warning against unintended deletion of the trigger definition.

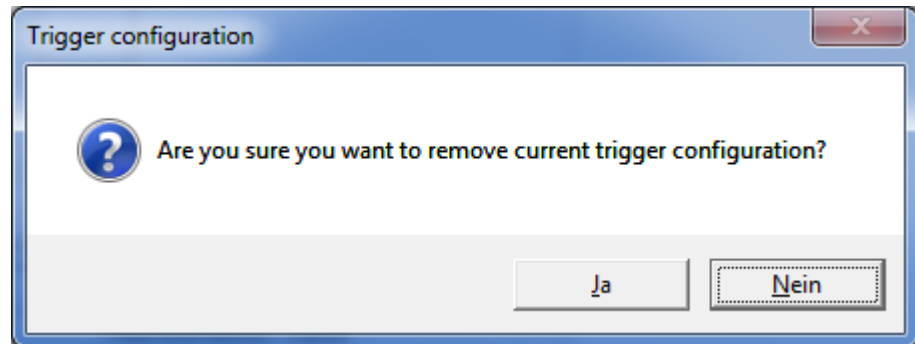

Figure 164: Safety request prior to deletion of trigger logic

- ⇒ If the safety request is answered with "Yes", then the trigger definition including the entry in the trigger selection list and the trigger logic is deleted.

10.8.4 The graphical editor area

The graphical editor area is used for defining (sometimes complex) trigger conditions for data recording. In general, proceed as follows:

Working with the graphical editor area

- Drag the necessary variables from the signal table (see *Working with signals* [▶ page 202]) within the source area of the trigger view or alternatively directly from the item list into the graphical editor area.
- If you need constants, for instance for comparison purposes, drag these from the constants table (see *Working with constants* [▶ page 205]) in the source area of the trigger view into the graphical editor area.
- Drag the required function blocks from the function blocks area into the graphical editor area.
- If necessary, configure the function blocks accordingly. Take care of the possibility of type conflicts, see *Functional blocks area* [▶ page 219].
- Connect the input and output signals of variable, constant and function blocks with another according to your needs by clicking with the mouse button onto one endpoint of the connection and dragging the mouse cursor to the other endpoint of the connection.
- If you want to erase a connection line or a block, then click at the cross symbol right above the right end of the line or the block.
- In standard mode of operation, click at button *Activate* in the window bar to test your trigger definition.

- ⇒ If no errors occur (see *Window bar of trigger window* [▶ page 199]), the trigger definition is activated and the display **Active** appears at right upper corner of the configuration area. The trigger definition has been tested for correctness and activated. Otherwise eliminate the error causes mentioned within the error message and click again at the *Activate* button.

10.8.5 Sources area

The following figure Sources Area illustrates the sources area:

Signal	Name	Type	
VAR0	Gerät 3 (EtherCAT).Registers.Configured Station Address.Configured Station Address.Address used for node addressing (FPxx commands).BWR	UINT	x
VAR1	Gerät 3 (EtherCAT).Registers.AL Status.AL Status.Actual State of the Device State Machine.BRD	BIT4	x
VAR2	Gerät 3 (EtherCAT).Registers.FMMU 0.FMMU 0.Logical start address.BWR	DINT	x
VAR3	Gerät 3 (EtherCAT).Registers.FMMU 0.FMMU 0.Logical start bit.BWR	BIT3	x
VAR4	Gerät 3 (EtherCAT).Registers.FMMU 0.FMMU 0.Logical stop bit.BWR	BIT3	x
VAR5	Gerät 3 (EtherCAT).Registers.FMMU 0.FMMU 0.Length.BWR	UINT	x
VAR6	Gerät 3 (EtherCAT).Registers.SyncManager 0.SyncManager 0.Physical start address.BWR	UINT	x
VAR7	Gerät 3 (EtherCAT).Registers.SyncManager 0.SyncManager 0.Operation mode.BWR	BIT2	x
VAR8	Gerät 3 (EtherCAT).Registers.SyncManager 0.SyncManager 0.Direction.BWR	BIT2	x

Const	Name	Type	Representation	Value	
CONST0	Zero	DINT	Decimal	0	x
CONST1	Mask1	BIT8	Binary	00000000	x
CONST2	Mask2	BIT8	Binary	00000000	x
CONST3	Mask3	BIT8	Binary	00000000	x
CONST4	Mask4	BIT8	Binary	00000000	x
CONST5	Mask5	BIT8	Binary	00000000	x
CONST6	Mask6	BIT8	Binary	00000000	x
CONST7	Mask7	BIT8	Binary	00000000	x
CONST8	Mask8	BIT8	Binary	00000000	x
CONST9	...	BIT8	Binary	00000000	x

Figure 165: Sources Area

It informs about signal definitions in its upper part and allows you to define constants in the lower part.

10.8.5.1 Working with signals

All currently used signals are displayed in the signal definition table. In this context, signals are these

Standard Ethernet	timing variables, netload variables and custom value filters
EtherCAT	register contents and variables
PROFINET	variables and communication events
GPIO	GPIO variables

Table 78: Applicable signals

The signal definition table is maintained automatically by netANALYZER Scope. This means, every time one of the signals from the element list (in item view) is dragged to the graphical editor area (right part of trigger view) and dropped there, a new line for the newly defined signal is created in the signal definition table.

Example

The example for the signal table displayed below shows the following kinds of signals:

- 2 PROFINET variables (VAR0, VAR1)
- 1 timing variable (VAR2)
- Several netload variables

Signal	Name	Type	
VAR0	et200sp.DQ 8x24VDC/0.5A ST V1.0.DQ 8x24VDC/0.5A ST V1.0.Ausgänge.0	BIT1	x
VAR1	et200sp.AQ 4xU/I ST V1.1.AQ 4xU/I ST V1.1.A-Kanal 0	INTEGER16	x
VAR2	Cycle time, FrameID 0x8000, port 0	INTEGER64	x
VAR3	Broadcast frames @ 1s, port 0	REAL64	x
VAR4	Multicast frames @ 1s, port 0	REAL64	x
VAR5	ARP frames @ 1ms, port 0	REAL64	x
VAR6	LLDP frames @ 1ms, port 0	REAL64	x
VAR7	IPv4 frames @ 1ms, port 0	REAL64	x
VAR11	IPv6 frames @ 1ms, port 0	REAL64	x
VAR14	IPv6 multicast frames @ 1ms, port 0	REAL64	x
VAR15	ICMP frames @ 1ms, port 0	REAL64	x
VAR16	RT_CLASS_UDP frames @ 1ms, port 0	REAL64	x
VAR17	RT frames @ 1ms, port 0	REAL64	x
VAR18	RTA frames @ 1ms, port 0	REAL64	x
VAR19	RTA_CLASS_UDP frames @ 1ms, port 0	REAL64	x
VAR20	DCP Hello frames @ 1ms, port 0	REAL64	x
VAR21	DCP Get and Set frames @ 1ms, port 0	REAL64	x
VAR22	DCP Identify frames @ 1ms, port 0	REAL64	x
VAR23	MRP frames @ 1ms, port 0	REAL64	x
VAR24	SNMP frames @ 1ms, port 0	REAL64	x
VAR25	PTCP Sync frames @ 1ms, port 0	REAL64	x
VAR26	PTCP LineDelay frames @ 1ms, port 0	REAL64	x
VAR27	PTCP Announce frames @ 1ms, port 0	REAL64	x
VAR28	all frames @ 1ms, port 0	REAL64	x
VAR29	UDP frames @ 1ms, port 0	REAL64	x
VAR30	TCP frames @ 1ms, port 0	REAL64	x

Figure 166: Signaldefinitionstabelle

The signal definition table has the following columns:

Signal

In netANALYZER Scope, signals respectively the corresponding variables are internally numbered in the Signal column (VAR0, VAR1 and so on) of the signal definition table.

Name

The actual name of signal is automatically taken over from the name on the variable within the EtherCAT or PROFINET structure tree within the item view.

Type

The data type of the variable associated with the signal is assigned in the column *Type* of the constants definition table.

- For EtherCAT, the available data types are listed in *List of supported data types for variables* [▶ page 76].
- For PROFINET, the available data types are listed in *List of supported data types for PROFINET variables* [▶ page 78].
- For timing variables, the data type is always `INTEGER64`.
- For netload variables, the data type is always `REAL64`.
- For custom-defined filters, the data type is always `BOOLEAN`.
- For GPIO, the data type is always `VISIBLE_STRING`.



Note:

When setting a GPIO output as trigger event, take care of this process happening without a defined delay time. Depending on trigger and hardware configuration some 100 ms delay can pass between the occurrence of the event and setting the GPIO!

Definitions are not made in the table itself, the table is only for information purpose.

You can use variables by dragging their item from the item list view to the area of the graphical editor for trigger conditions. (These are automatically updated within the signal table.)



Note:

For more information, see sections *Working with the item list view* [▶ page 91] and *The graphical editor area* [▶ page 201].

Adding a signal to the signal table

1. In order to add a signal to the signal table, proceed as follows:
 - Drag the respective element (variable) with pressed mouse button from the item list to the graphical editor area (right part of the trigger view).
 - ⇒ A new line for the signal will be created in the signal table.
 - ⇒ A variable block for the signal will be created in the graphical editor area of the trigger view.

How to erase signals from the signal table

Signals can simply be erased by clicking at the cross in the most right column of the signal table.

2. Another way to erase a signal from the signal table:
 - Either click at the line of the signal to be erased.
 - ⇒ This line is now highlighted.
 - Now press the *Del* key on your keyboard.

What happens when doing so depends in both cases on whether the signal to be erased is already used by a trigger definition, or not.

- If the signal is not used by a trigger definition, it will be erased immediately.
- If the signal is used by a trigger definition, the following safety message box will appear:

In this case, check whether erasing the variable really makes sense as at least a part of the trigger logic will not work when you continue with “Yes”.

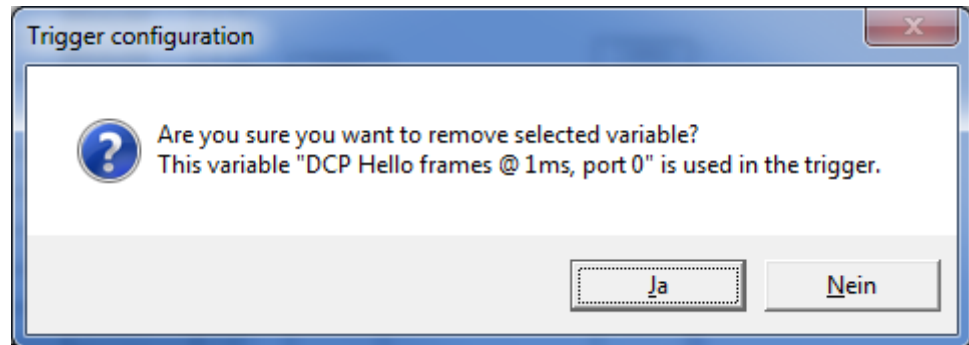

Figure 167: Error Message appearing when trying to erase an already used variable

You can use signals by simply dragging them from their line in the signals definition table to the area of the graphical editor for trigger conditions.

10.8.5.2 Working with constants

Const	Name	Type	Representation	Value	
CONST0	Zero	DINT	Decimal	0	x
CONST1	Mask1	BIT8	Binary	00000000	x
CONST2	Mask2	BIT8	Binary	00000000	x
CONST3	Mask3	BIT8	Binary	00000000	x
CONST4	Mask4	BIT8	Binary	00000000	x
CONST5	Mask5	BIT8	Binary	00000000	x
CONST6	Mask6	BIT8	Binary	00000000	x
CONST7	Mask7	BIT8	Binary	00000000	x
CONST8	Mask8	BIT8	Binary	00000000	x
CONST9	...	BIT8	Binary	00000000	x

Figure 168: Constant Definition Table

In the context of trigger definition, constants are needed mainly in comparisons.

Assigning values to constants is done within a table, the constant definition table.

In netANALYZER Scope, constants are internally numbered in the column *Const* (CONST0, CONST1 and so on) of the constant definition table. They may be assigned to a more speaking name by entering such a name in the Name column.

The data type of the constant is assigned in the column *Type* of the constants definition table. The following data types are available:

- Boolean value
- Visible string
- Octet string
- Unicode string
- Floating-point value
- Signed value
- Unsigned value

In the column representation the data representation of the constant can be adjusted. It depends on the data type.

For Boolean values the following kinds of representation are available.

- Binary representation (0,1)
- Boolean representation (`FALSE`; `TRUE`)
- For signed and unsigned values, the following representations are allowed:
 - Decimal representation
 - Hexadecimal representation
- For floating-point values only the decimal representation is available..

For the data types Visible string and Octet string these representations are available:.

- Octet string representation (Octet string means byte string)
- ASCII String
- Windows-1252 string

For the data type Unicode string, the following representations are available:

- Octet string representation (Octet string means byte string)
- Unicode String

The actual assignment of a value to the constant takes place in the column *Value* (i.e. the second column from the right edge of the table). You can enter the value there.

Adding a constant to the constant definition table

In order to add a constant to the constant definition table, proceed as follows:

- Drag the lowest line in the constant definition table with pressed mouse button into the graphical editor area (right part of the trigger view). In this line, the entry in column *Name* is empty.
- ⇒ In the constant definition table, a new line for the constant will be created. In this new line, the entry in column *Name* is empty.
- ⇒ In the line above, the name of the constant appears.
- ⇒ A constant block is created in the graphical editor area of the trigger view.

**Note:**

For more information also see *Communication events* [▶ page 81].

Erasing constants from the definition table

Constants can be erased by clicking at the cross in the most right column of the definition table . What happens when doing so, depends on whether the constant to be erased is already used by the trigger definition, or not.

- If the constant is not used by the trigger definition, it will be erased immediately.
- If the constant is used by the trigger definition, the following safety message box will appear:

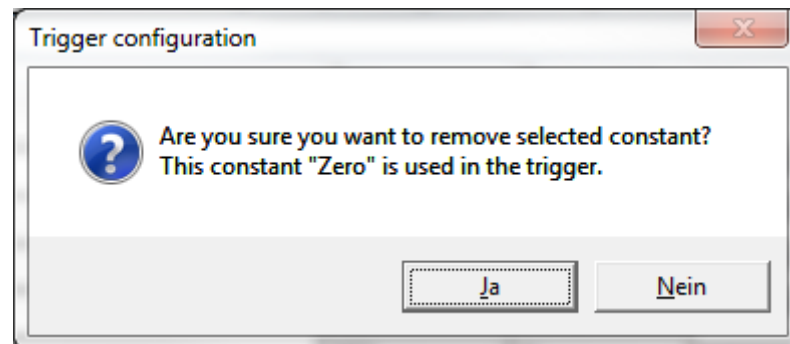

Figure 169: Error Message appearing when trying to erase an already used Constant

In this case, check whether erasing the constant really makes sense as at least a part of the trigger logic will not work when you continue with "Yes".

You can use constants by simply dragging them from their line in the constants definition table to the area of the graphical editor for trigger conditions.

10.8.6 Functional blocks area

Function blocks allow to conclude decisions out of the values of the signals and constants by logic processing of these. They are applied by dragging them from the functions block area into the workspace of the graphic editor and dropping them there.

The functional blocks area is subsequently displayed in figure *Functional Blocks Area*.

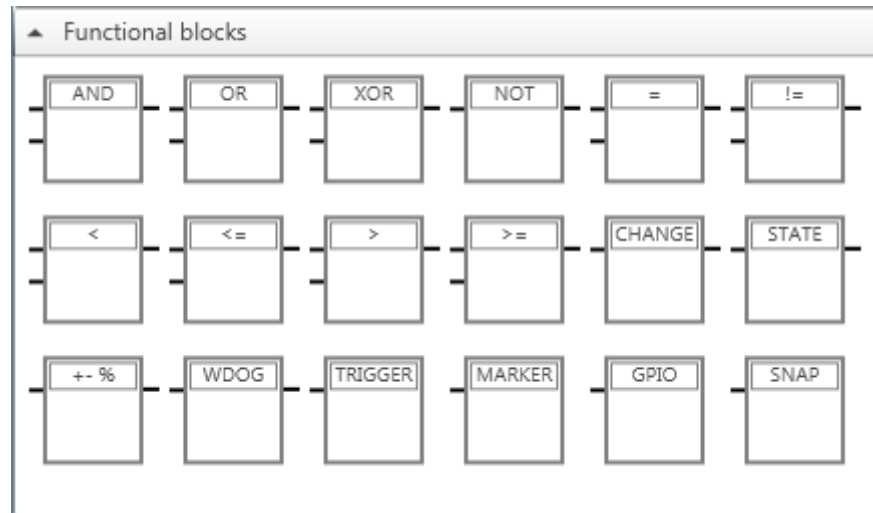

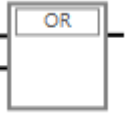
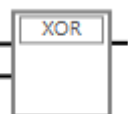









Figure 170: Functional Blocks Area

The subsequent tables *Funktion blocks for operations* and *Event-related function blocks* list the available function blocks for logic processing of signals and constants in the graphic editor.

Logical and arithmetic operations		
	AND	Logical AND operation
	OR	Logical OR operation
	XOR	Logical Exclusive-OR operation
	NOT	Logical negation operation
	=	Equality
	!=	Inequality
	<	Comparison: Less than
	<=	Comparison: Less or equal
	>	Comparison: Greater than
	>=	Comparison: Greater or equal
Other operations		
Symbol	Name	Meaning



Logical and arithmetic operations		
	CHANGE	Change detection
	STATE	Check for validity
	+-%	Function block "Deviation by percentage"
	WDOG	Watchdog event block

Table 79: Function blocks for operations

These function blocks perform logical (AND, OR, XOR, NOT), arithmetic or other comparison operations and do not only have inputs, but also outputs as well.

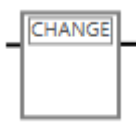
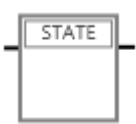
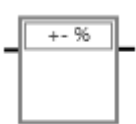

Symbol	Name	Meaning
	TRIGGER	Trigger block The recording is stopped after a well-defined time interval.
	MARKER	Marker block
	GPIO	General Purpose Input/ Output
	SNAP	Snapshot block

Table 80: Event-related function blocks



Function block "Release trigger event" (TRIGGER)

Requirements

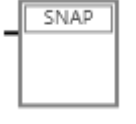
This function block cannot be used in autonomous operation mode!

Function

If the input is set to TRUE, a trigger event is released, i.e. after a configurable delay time (the delay time) data recording is stopped. The situation causing the trigger event can then be analyzed using the data having been recorded shortly before the end of data recording.

Inputs

1 input

Outputs

None

Controls

The button "Edit" opens a dialog box for specifying the delay time.

Dialog box

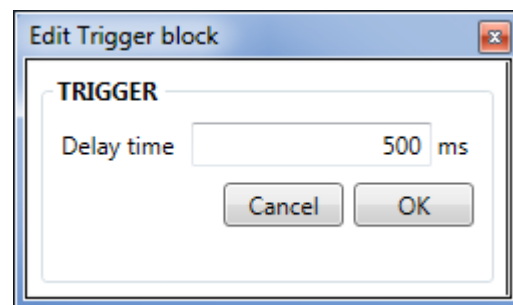

Figure 171: Dialog box "Edit trigger block"

The dialog box *Edit trigger block* contains an input field for specifying the delay time in units of milliseconds. If 0 is specified, netANALYZER Scope will stop data recording immediately after the occurrence of the trigger event. The default value is 500 milliseconds. The allowed range of values of the input field includes integer values between 0 and 4294967295 milliseconds.

Error handling

In case of specifying an invalid value (such as a value outside of the allowed range of values or a non-integer value), the color of the frame of the input field changes to red and the button Ok is greyed out and locked until the input error is corrected.



Function block "Change detection" (CHANGE)

Requirements

None

Function

The function block "Change detection" enables you to detect changes in its input signal. As long as the input signal remains on a constant level, it will deliver the value FALSE. As soon as it changes, the output switches to TRUE.

Inputs

1 input

Outputs

At least 1 output

Controls

None

Dialog box

Not present.



Function block "Validity check of state" (STATE)

Requirements

None

Function

If the input variable is valid, the output switches to TRUE.

Inputs

1 input

Outputs

At least 1 output

Controls

None

Dialog box

Not present.



Function block "Deviation by percentage" (+-%)

Requirements

None

Function

The deviation by percentage block is released (i.e. the output is set to TRUE) if the deviation of the input exceeds a formerly specified percent value. The deviation always refers to the first measured value.

Inputs

1 input

Outputs

At least 1 output

Controls

Input field for percentual value

Dialog box

Not present.



Function block "Watchdog event" (WDOG)

Preconditions

None

Function

The watchdog block triggers (i.e. sets its output signal to TRUE), if no change of the supervised input signal could be observed after a specified time has elapsed.

Inputs

1 input

Outputs

1 output

Controls

The button "Edit" opens the dialog box *Edit Watchdog block* for specifying the time out interval.

Dialog box

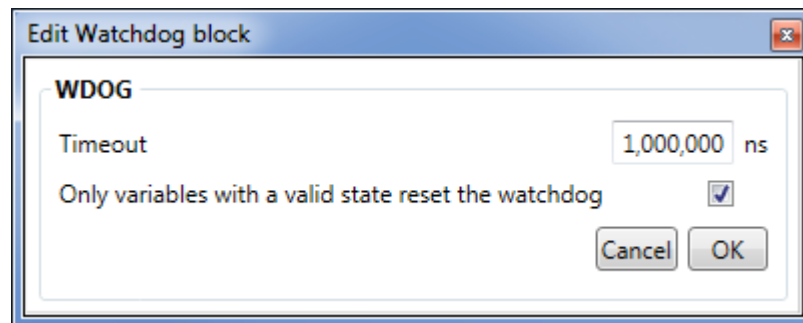

Figure 172: Dialog box "Edit Watchdog block"

The dialog box *Edit Watchdog block* contains an input field for specifying the time out interval in units of nanoseconds and a checkbox for deciding whether all variables or only those with valid status reset the watchdog if they change.

The default value of the time out interval amounts 1,000,000 nanoseconds (respectively 1 millisecond). The allowed range of values of the input field extends from 0 to 9,223,372,036,854,775,807 nanoseconds (integer values).

Error handling

In case of specifying an invalid value (such as a value outside of the allowed range of values or a non-integer value), the color of the frame of the input field changes to red..



Function block "Marker event" (MARKER)

Requirements

This function block cannot be used in autonomous operation mode!

Function

If the input value changes, a marker is set in the chart. Contrary to the trigger block, recording is continued.

Inputs

1 input

Outputs

None

Controls

Button "Edit" opens a dialog box for specifying the marker name and selecting between rising and falling edge triggering.

Dialog box

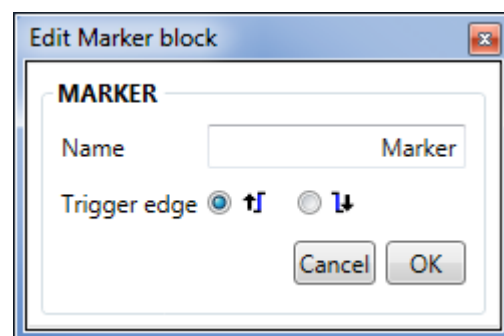

Figure 173: Dialog box "Edit marker block"

The dialog box *Edit marker block* contains an input field *Name* for specifying the marker name and radio buttons for deciding between rising edge triggering (Condition switches to TRUE) and falling edge triggering (Condition switches to FALSE). The default name for the input field *Name* is *Marker*.

Error handling

If the name of the marker is too long, the color of the frame around the input field changes to red and the button *Ok* is locked.



Function block "Set GPIO temporarily"

Requirements

The selected GPIO signal (No. 0...3) must be configured as Output (Trigger) in the Device assignment menu!

Function

The GPIO block sets the specified GPIO signal for the specified time interval.

Inputs

1 input

Outputs

None

Controls

The button "Edit" opens a dialog box for specifying the GPIO number and the reset delay. Schaltfläche „Editieren“ öffnet eine Dialogbox zur Eingabe der GPIO-Nummer und der Reset-Verzögerung.

Dialog box

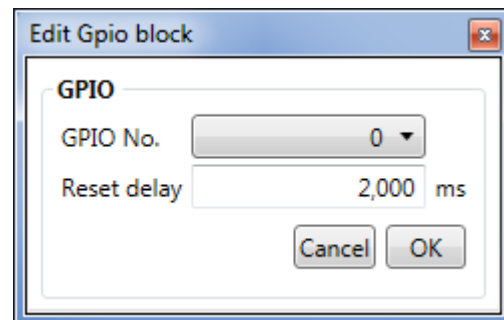
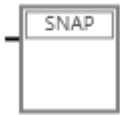

Figure 174: Dialog box "Edit GPIO-Block"

The dialog box *Edit GPIO-Block* contains a selection list *GPIO No.* for the GPIO signal to be used (Values 0, 1, 2 and 3 to be chosen) and an input *field Reset delay* for specifying the reset delay in units of milliseconds. For this time the according GPIO signal remains set. The default value amounts 2000 milliseconds. The allowed range of values of the input field includes integer values between 0 and 4294967295 milliseconds..



Function block "Snapshot generation" (SNAP)

Requirements

This function block can only be used in autonomous operation mode!

Function

If the condition is fulfilled (TRUE), a snapshot is generated.

Inputs

1 input

Outputs

None

Controls

The button „Edit“ opens the dialog box "Edit Snapshot block" for specifying the lead time and the delay time.

Dialog box

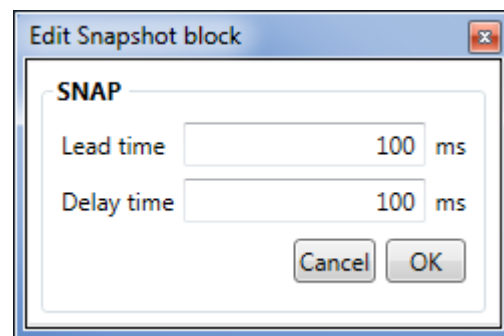

Figure 175: Dialog box "Edit Snapshot block"

The dialog box *Edit Snapshot block* contains two input fields for specifying lead time and delay time in units of milliseconds. The default value amounts for both field 100 milliseconds each. The allowed range of values of the input field includes integer values between $-9.223.372.036.854$ and $9.223.372.036.854$ milliseconds.

Notice that the duration of a snapshot depends on the bus load and the recorded amount of data within this time interval.

The netANALYZER NANL-B500G-RE supplies at maximum 300 MB of data memory. When a snapshot event occurs, frames can be stored only within these limits

Error handling

In case of specifying an invalid value (such as a non-integer value), the color of the frame of the input field changes to red until the input is corrected.

Recognition of conflicts

In comparisons, types must match between the signal to be compared and the value with which the signal is compared (either another signal or a constant). If there is a mismatch, netANALYZER Scope detects this on its own and displays the connection lines of this signals/constants to the function block performing the comparison in red. For example, see the illustration below:

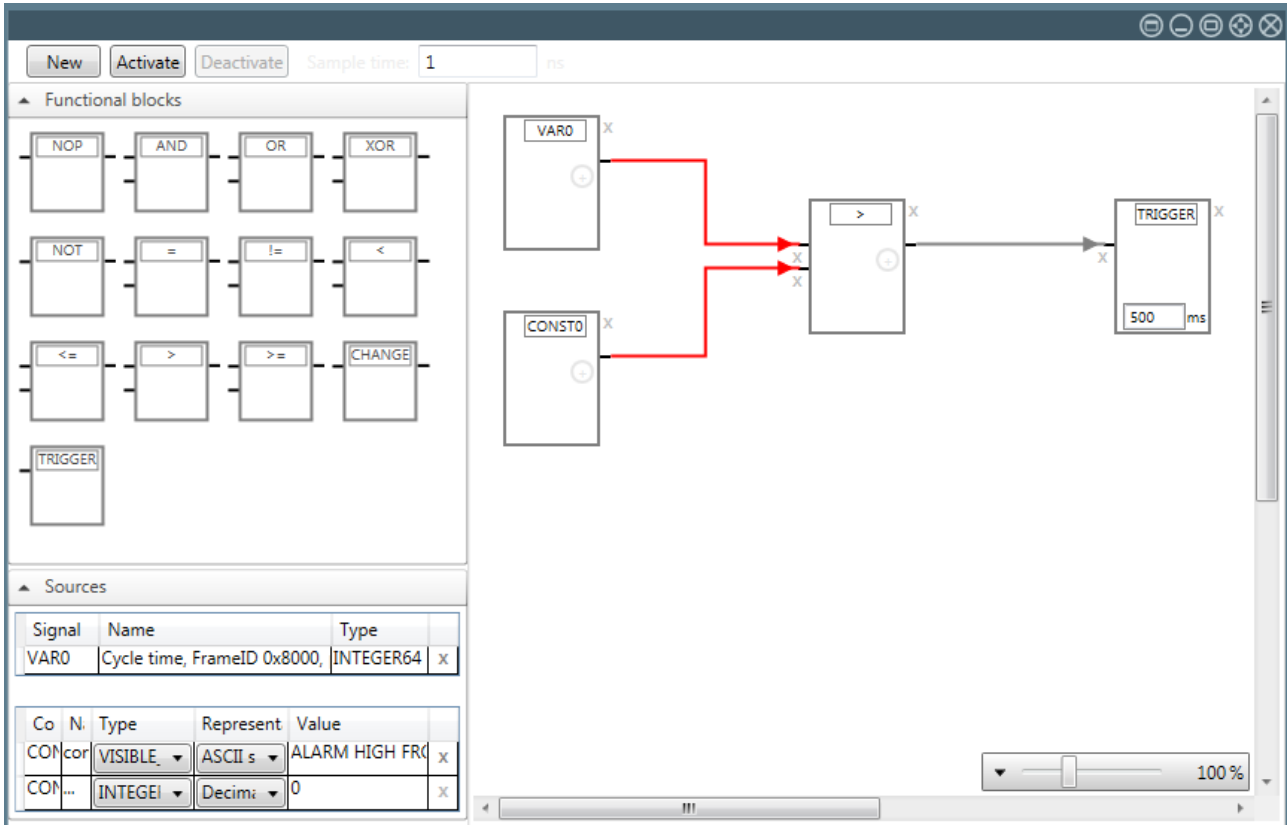

Figure 176: Type mismatch error between signal and constant in comparison

The type conflict in this example consists in the comparison of a numeric value (Signal VAR0 of type INTEGER64 with a constant (CONST0) of type VISIBLE STRING. Trying to activate this trigger would cause this message box to appear:

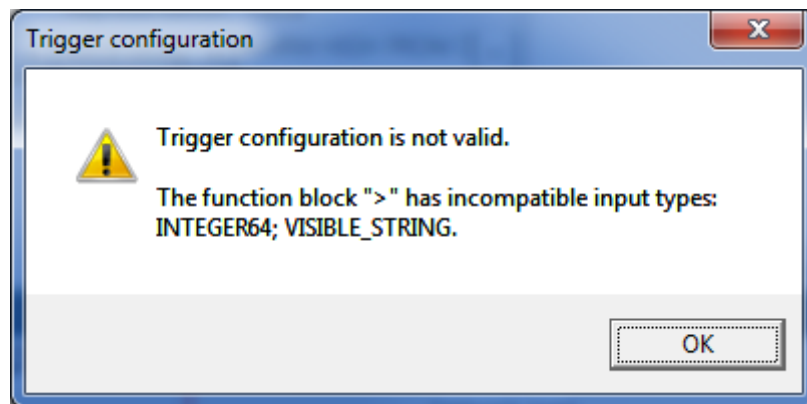

Figure 177: Type conflict message

If the types of all compared values (signals, constants) match, these connection lines will be **black**.

Another message may appear when types do not match in a comparison:

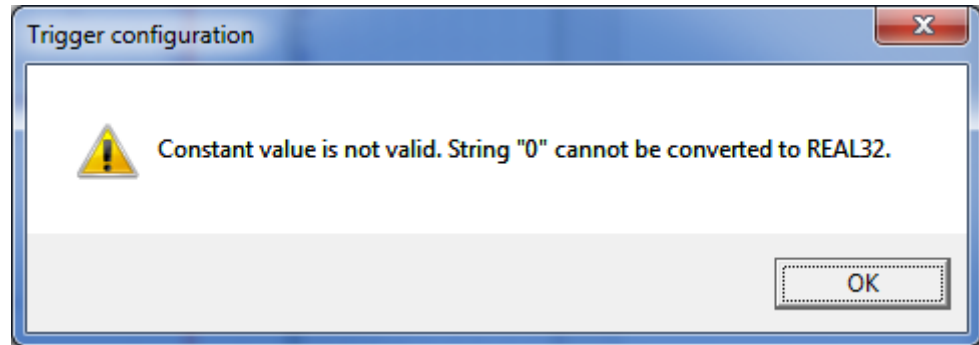

Figure 178: Type conflict in comparison

In this example, two constants of different types have been compared, one of type REAL32 and one of type INTEGER32. In this case an automatic conversion takes place. The message informs about the failure of this automatic conversion. In order to correct your trigger configuration, do not use integer values to initialize values of constants of REAL types.

During data recording the trigger is recalculated continuously. Complex trigger conditions and short cycle times require much computing power from the PC. If there is a lack of available computing power, recording is cancelled with the subsequent error code:

```
0xC066000B NETANA_CAPTURE_ERROR_NO_HOSTBUFFER
```

```
No free DMA buffer available. Host is too slow to  
handle data efficiently.
```

or depending on the overflow behavior settings in "Options" (see section *Define behavior at overload error* [▶ page 45]) telegrams are rejected.



Note:

For more information see section *Error messages*.

10.9 Quick-tester view

Beginning with version 2.8, netANALYZER Scope provides the quicktester view. Insightful PROFINET analyses without any configuration effort can be performed easily this way. Even long-time analyses running for days or weeks are possible.

The quicktester view allows quick analyses, which devices communicate with which other ones, whether the cyclic communication operates correctly and how much jitter occurs.

The quicktester view offers the following advantages to you:

1. Lists of all participating PROFINET and Ethernet Devices
2. An overview of all logical connections
3. Automatic supervision of cyclic frames
4. Network load can be displayed depending on affected protocols and frame types.
5. Decoding of alarms with clear text possible
6. Automatic detection of serious network events such as change of address, violation of timing conditions or newly established communication relations.

**Note:**

The data acquired by the Quicktester are held independently from the contents of the ring buffer. This means that Quicktester data will not be overwritten, when the ringbuffer is overwritten. This allows a long-time supervision with the Quicktester without any limitation by the amount of frame data in the ring buffer.

Therefore, take care of possible differences in the covered time intervals between the representation in the Chart View on one hand and the data export in PCAP Format on the other hand.

Open a new quicktester view

The quicktester view can be opened as follows:

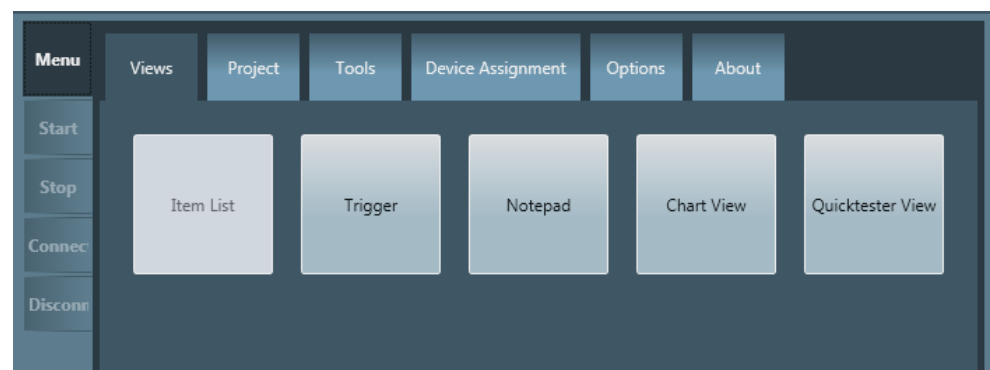

Figure 179: Menu Pane Views

1. To open a quicktester view window:
 - Select the menu option *Quicktester View*.
 - ⇒ A Quicktester view window is opened within the application window of netANALYZER Scope.

The quicktester view window has three different register cards, which are described subsequently:

10.9.1 Register cards of quicktester view

The quicktester view provides the following register cards for easy and quick analysis of acquired data:

- Conversation table
- Sequence in time (Traffic shape)
- Event log

10.9.1.1 Conversation table

The conversation table provides a list of participants containing a table listing of all network devices which displays the conversations, i.e. the logical communication relations between the network devices. This table shows between which participants a conversation has occurred using which protocol.

If all lines are compressed (not expanded), the conversation table looks like this:

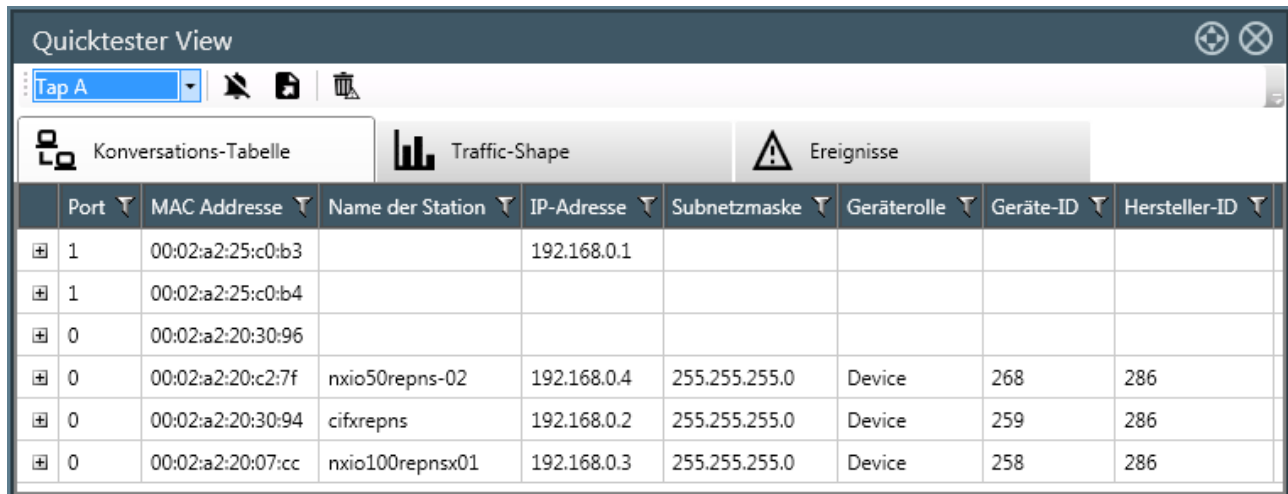

Port	MAC Adresse	Name der Station	IP-Adresse	Subnetzmaske	Geräterolle	Geräte-ID	Hersteller-ID
1	00:02:a2:25:c0:b3		192.168.0.1				
1	00:02:a2:25:c0:b4						
0	00:02:a2:20:30:96						
0	00:02:a2:20:c2:7f	nxio50repns-02	192.168.0.4	255.255.255.0	Device	268	286
0	00:02:a2:20:30:94	cifxrepns	192.168.0.2	255.255.255.0	Device	259	286
0	00:02:a2:20:07:cc	nxio100repnsx01	192.168.0.3	255.255.255.0	Device	258	286

Figure 180: Conversation table (compressed)

The Conversation table in this state shows a line for each network device with the following specifications each listed within an own table column:

- Port
- MAC address
- Name of station
- IP address
- Subnet mask
- Device role

- Enter the Device ID into the field Device ID.
- Vendor ID (as assigned by the PROFIBUS-Nutzerorganisation e.V.)

**Note:**

All data are extracted from the ongoing frame traffic. If single values of these are not transferred, these cannot be detected. In this case, the corresponding fields in the Quicktester view remain empty.

All specifications apply to the respective network device as source of conversation. The conversation table can be sorted regarding to all these columns, see below. Similarly the conversation table can be filtered regarding to all these columns. In the following filtering is explained using the example of the column **Port**:

Example: Filtering by Vendor ID

If you want to restrict the display to show only events of a certain port, proceed as follows:

- Click at the symbol right at the column head (here: of Port)
- the filter dialog is displayed.

Figure 181: Filter dialog Vendor ID

In the upper list, you can for instance select the desired Vendor ID, selection of the value 286 restricts the display to show only events of Hilscher devices identified by Hilscher's PROFINET-Vendor ID 286.

You can as well define two logical conditions, which the value of Vendor ID must match simultaneously.

The following comparison operators can be selected:

- Equality
- Inequality
- Begins with
- Ends with
- Contains
- Does not contain

- Is contained
 - Is not contained
 - Is empty
 - Is not empty
 - Is less than
 - Is less than or equal
 - Is greater than
 - Is greater than or equal
 - Is Null
 - Is not Null
- Within the filter dialog, click at **Filter** in order to activate the chosen filter settings and conditions.

You can invalidate the chosen filter settings and conditions as follows:

- Within the filter dialog, click at **Clear Filter** .

At the left edge of the conversation table there is another column containing plus symbols surrounded by a square frame, You can expand the respective line by clicking at the plus symbol, i.e. an additional table is displayed below the line of the main table which contains valuable information concerning all communication partners and more, see figure below:

Port	MAC Adresse	Name der Station	IP-Adresse	Subnetzmaske	Geräterolle	Geräte-ID	Hersteller-ID	
1	00:02:a2:25:c0:b3		192.168.0.1					
MAC Adresse	Name der Station IP-Adresse Subnetzmaske	Frame-Anzahl	Geräte-ID Hersteller-ID Geräterolle	Min. Zykluszeit in ns Max. Zykluszeit in ns Erwartete Zykluszeit in ns Fehlende Frames	Protokoll Typ Frame Id	Erstmals erschienen Zuletzt erschienen		
01:0ec:f000000		4			Protokoll Typ : DCP Frame Id : 0xFFFE	Erstmals erschienen : 09:01:13:55:44:737ms 175us 192ns Zuletzt erschienen : 09:01:13:55:46:938ms 041us 872ns		
ff:ff:ff:ff:ff:ff		3			Protokoll Typ : ARP	Erstmals erschienen : 09:01:13:55:47:939ms 941us 902ns Zuletzt erschienen : 09:01:13:55:47:940ms 101us 372ns		
00:02:a2:20:c2:7f	Name der Station : nxio50reps-02 IP-Adresse : 192.168.0.4 Subnetzmaske : 255.255.255.0	3	Geräte-ID : 268 Hersteller-ID : 286 Geräterolle : Device		Protokoll Typ : UDP/IP	Erstmals erschienen : 09:01:13:55:47:941ms 087us 492ns Zuletzt erschienen : 09:01:13:55:47:974ms 515us 342ns		
00:02:a2:20:30:94	Name der Station : cifxreps IP-Adresse : 192.168.0.2 Subnetzmaske : 255.255.255.0	3	Geräte-ID : 259 Hersteller-ID : 286 Geräterolle : Device		Protokoll Typ : UDP/IP	Erstmals erschienen : 09:01:13:55:47:941ms 882us 822ns Zuletzt erschienen : 09:01:13:55:47:967ms 394us 812ns		
00:02:a2:20:07:cc	Name der Station : nxio100repsv01 IP-Adresse : 192.168.0.3 Subnetzmaske : 255.255.255.0	3	Geräte-ID : 258 Hersteller-ID : 286 Geräterolle : Device		Protokoll Typ : UDP/IP	Erstmals erschienen : 09:01:13:55:47:942ms 584us 202ns Zuletzt erschienen : 09:01:13:55:47:968ms 366us 732ns		
00:02:a2:20:30:94	Name der Station : cifxreps IP-Adresse : 192.168.0.2 Subnetzmaske : 255.255.255.0	709	Geräte-ID : 259 Hersteller-ID : 286 Geräterolle : Device	Min. Zykluszeit : 15,977,750 Max. Zykluszeit : 16,017,350 Erwartete Zykluszeit : 16,000,000 Fehlende Frames : 0	Protokoll Typ : Profinet RT Frame Id : 0x8030	Erstmals erschienen : 09:01:13:55:47:962ms 766us 912ns Zuletzt erschienen : 09:01:13:55:59:290ms 333us 242ns		
00:02:a2:20:07:cc	Name der Station : nxio100repsv01 IP-Adresse : 192.168.0.3 Subnetzmaske : 255.255.255.0	709	Geräte-ID : 258 Hersteller-ID : 286 Geräterolle : Device	Min. Zykluszeit : 15,981,910 Max. Zykluszeit : 16,020,630 Erwartete Zykluszeit : 16,000,000 Fehlende Frames : 0	Protokoll Typ : Profinet RT Frame Id : 0x8030	Erstmals erschienen : 09:01:13:55:47:963ms 768us 872ns Zuletzt erschienen : 09:01:13:55:59:291ms 325us 842ns		
00:02:a2:20:c2:7f	Name der Station : nxio50reps-02 IP-Adresse : 192.168.0.4 Subnetzmaske : 255.255.255.0	709	Geräte-ID : 268 Hersteller-ID : 286 Geräterolle : Device	Min. Zykluszeit : 15,974,230 Max. Zykluszeit : 16,023,150 Erwartete Zykluszeit : 16,000,000 Fehlende Frames : 0	Protokoll Typ : Profinet RT Frame Id : 0x8030	Erstmals erschienen : 09:01:13:55:47:964ms 762us 592ns Zuletzt erschienen : 09:01:13:55:59:292ms 326us 002ns		
1	00:02:a2:25:c0:b4							
0	00:02:a2:20:30:96							
0	00:02:a2:20:c2:7f	nxio50reps-02	192.168.0.4	255.255.255.0	Device	268	286	
0	00:02:a2:20:30:94	cifxreps	192.168.0.2	255.255.255.0	Device	259	286	
0	00:02:a2:20:07:cc	nxio100repsv01	192.168.0.3	255.255.255.0	Device	258	286	

Figure 182: Conversation table (Second line visible)

Each line of this table contains information about exactly one single communication partner of the network device and information about the communication with this communication partner.

Column	Information	Meaning
Information concerning the communication partners of the network device		
2	MAC address	MAC address of participant of network communication
3	Name of station	Name of PROFINET-Station
3	IP address	If this list is still empty yet or the IP address of the Edge Gateway is missing in it, specify the IP address within the input field or click at the cog wheel symbol at the right and specify the IP address in the dialog box which will appear.
3	Subnet mask	Subnet mask of participant of network communication
4	Frame count	Number of registered frames
5	Device ID.	Device ID of the participant of the network communication
5	Vendor ID as assigned by the PROFIBUS-Nutzerorganisation e.	Vendor ID of the participant of the network communication
5	Device role	Device role
Additional information related to communication		
6	Minimum cycle time	Minimum cycle time specified in nanoseconds only at cyclic communication
6	Maximum cycle time	Maximum cycle time specified in nanoseconds only at cyclic communication
6	Expected cycle counter	Expected cycle counter only at cyclic communication
6	Missing frames	Number of missing frames detected for this cyclic connection
7	Product type	Kind of connection
7	Frame Id	Frame Id of PROFINET connection
8	First time appearance	Timestamp of first appearance of a frame of this connection
8	Last time appearance	Timestamp of last appearance of a frame of this connection

Table 81: Detailed additional specifications concerning the communication partners.

For cyclic connections, additionally a statistic analysis of the time distances is performed. The results of this analysis can be displayed both in column 6 of the table (minimum, maximum and expected cycle time) and graphically in the shape of a distribution function, see below.

To expand the graphic display click at the plus symbol (+) at the beginning of the line (left side). For instance, the next figure shows clearly a Gaussian distribution for the examined cyclic signal. This significantly eases the detection and evaluation of jitter.

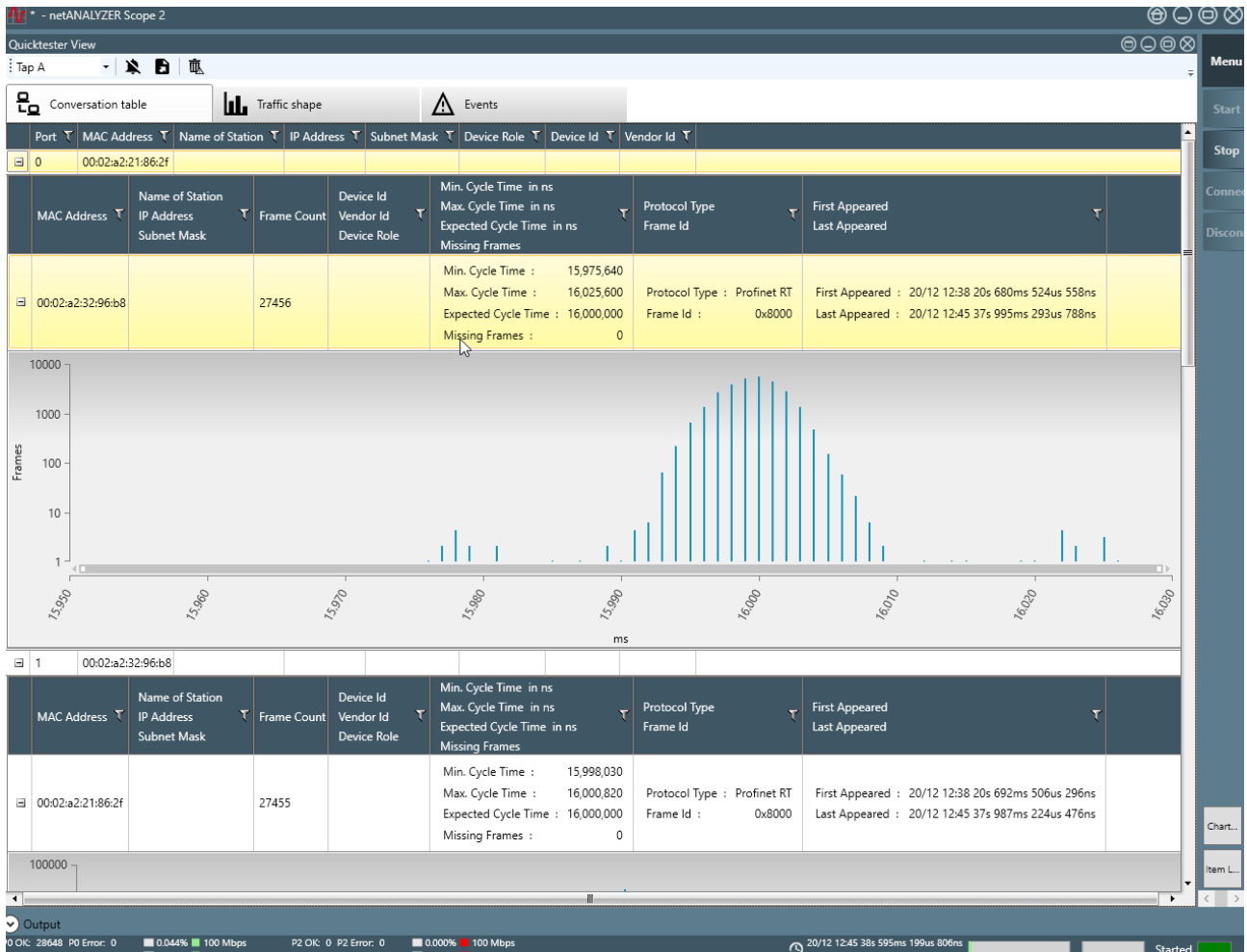

Figure 183: Conversation table

If you intend to change the scale of the time axis, you can achieve this using the mouse wheel.

If you intend to shift the display to the left or to the right side, you can achieve this by clicking into the display and dragging the display with pressed mouse button to the left or right direction.

If the selected signal is not cyclic, no information on the behavior of the connection over the time are collected and a message text indicating that *no data could be drawn* is shown.



Note:

The number of entries within the conversation table is restricted to 1000 entries. If more entries are added, these will be cancelled and an according message will be issued.

10.9.1.2 Automatic evaluation of the time dependence of the protocol usage distribution on the network (Traffic shape)

The register card **Traffic shape** displays the protocol usage (for instance TCP/IP, UDP/IP, ARP, DCP, MRP, PTCP, PROFINET RT, PROFINET RTA) within a diagram in dependence of the time (horizontal axis). Such a display allows the automatic determination of the protocol distribution on the network. So, long-time measurements of average values can be performed for longer periods as it is possible with frame data taken from the ring buffer.

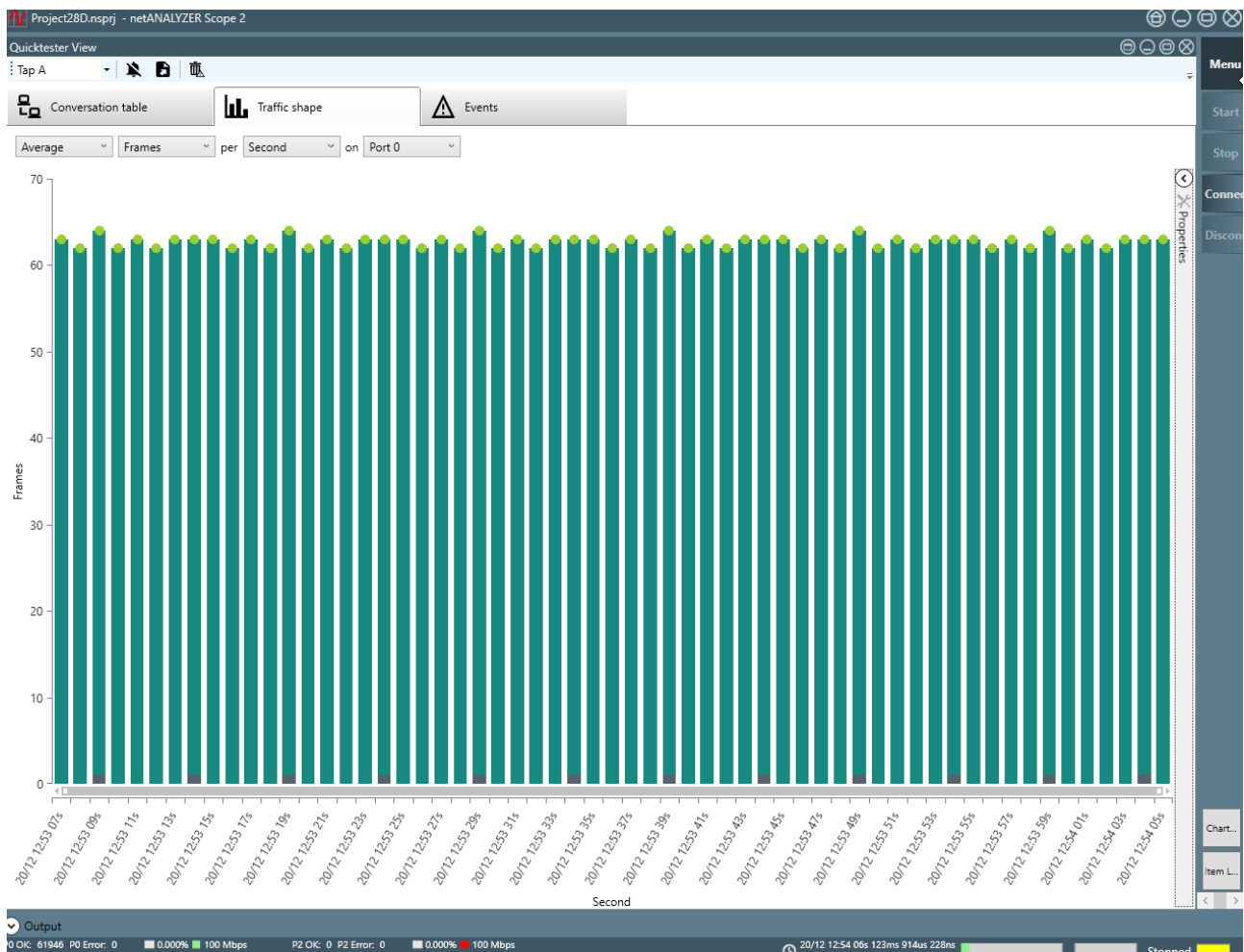

Figure 184: Display of the time dependence of the protocol usage distribution in the network's data traffic

The contributions of the various used protocol types to the entire network traffic are marked by colors according to the legend that can be switched on at the right edge of the register card.

Generally, on the vertical axis of the display the number of events at a certain port of the netANALYZER during a certain unit of time is displayed. At the upper edge of the display four expandable lists are provided in order to select the available display options.

- List 2 defines the kind of event to be counted: Number of frames, number of octets or percentage display.
- List 3 defines the used time unit, for which an average value is to be determined. The selection options are *second* or *minute*.

10.9.1.3 Event log

The event log allows the automatic, table-based logging of error events. It provides the basic information concerning all events that the quicktester view could detect from its analysis of the acquired data, usefully in shape of a table. A special advantage of the event log is that it supports mentioning PROFINET alarms in clear text.

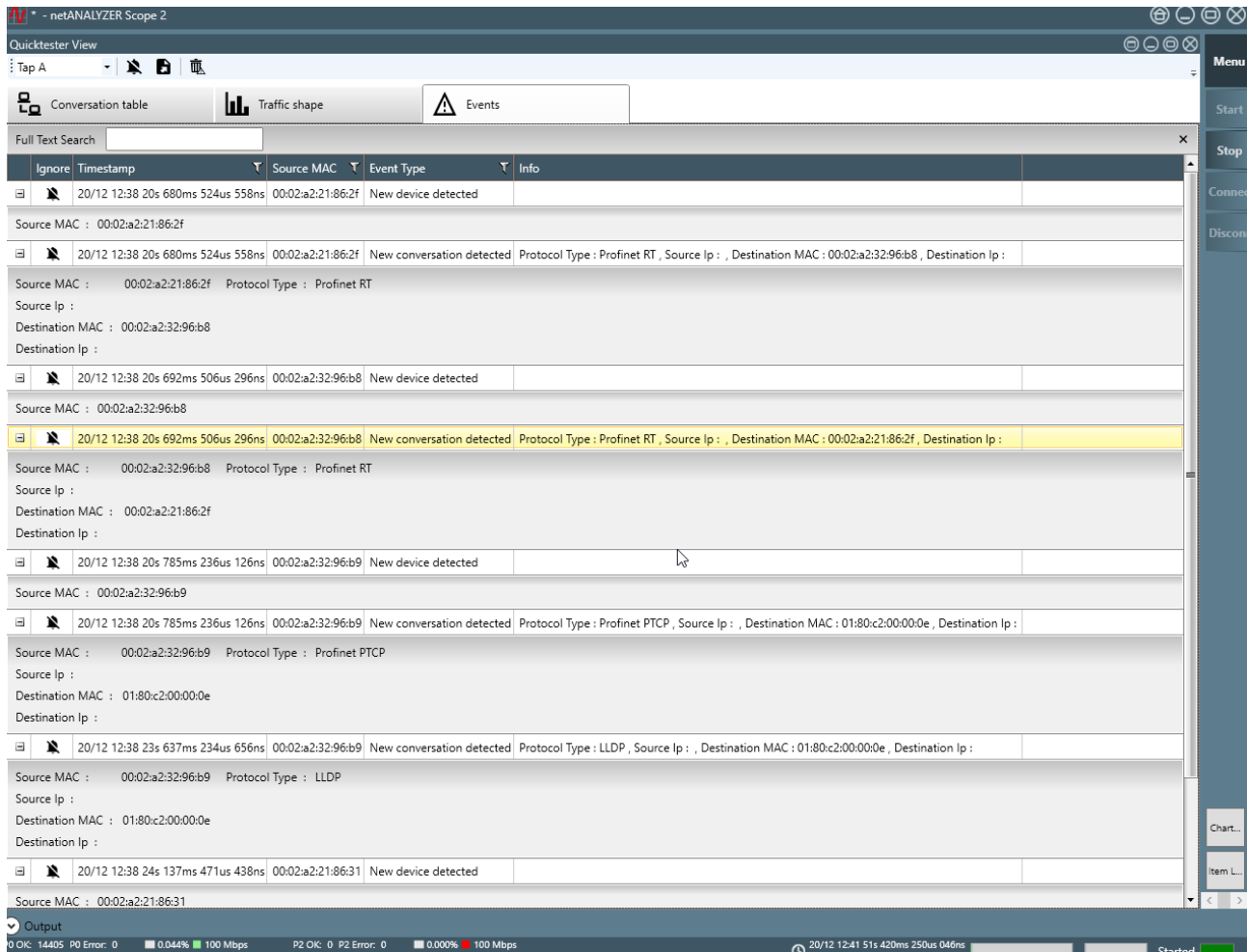

Figure 185: Event log

The event log is structured as follows:

Column name	Meaning
Ignore	Button for taking over the currently selected entry into the ignore list. The ignore list is a dialog for not taking into account selected kinds of events. See <i>Ignore list</i> [page 233]
Time stamp	Time stamp with nanosecond accuracy (taken at the time of occurrence of the event)
Source MAC	Source MAC address MAC address of sender of the data at the event
Event type	Type of event as explained by the subsequent table
Info	Additional information depending on the type of event

Table 82: Columns of event log

The following list contains all supported event types that might occur in the event log.

Type	Meaning
New MAC address detected	New MAC address detected
New conversation detected	New conversation detected
Device startup detected	Device startup detected
IP Address changed	IP Address changed
Jitter threshold exceeded	Jitter threshold exceeded by more than $\pm 50\%$
Name of Station changed	Name of Station changed
PROFINET Alarm detected	PROFINET Alarm detected
Subnet mask has changed	Subnet mask has changed
Unexpected cycle counter	Unexpected cycle counter
DCP event	A DCP frame occurred

Table 83: Possible event types in event protocol

Additionally, there is an expandable display row below each permanently visible row for detail information. In order to expand this second display row for detail information, click at the + symbol at the beginning of the row (left side). The displayed information depends on the type of event.



Note:

The number of entries within the event log is limited to 1000 entries. If there are additional entries exceeding this limit, these entries will be ignored and an according message will be issued.

Filtering within the event log can be applied for the following criteria:

- Time stamp
- Source MAC
- Event type

Proceed as follows in order to find a term occurring in the columns of the event log using the full-text search function:

- Specify the term to be searched for into the field **Full-text search**.
- ⇒ The display is restricted to showing only such events where the specified term occurs.

If you specify `Protocol` in field **Full-text search**, only those entries will be displayed in the event log which contain a specification regarding the protocol. If you specify `DCP` in field **Full-text search**, only entries concerning DCP are displayed within the event log. The search term is marked in red color at all locations of column Info where it was found.

The event log only displays those events that do not match the criteria defined within the ignore list (i.e. the list of event types not to be taken into account).

By clicking at column **Ignore** the criteria on that the selected entry is based can be transferred to the ignore list.



Note:

See *Ignore list* [▶ page 233].

10.9.1.4 Example for the analysis of network communication using the event log

The following figure shows a realistic event log of the communication of various network participants via multiple protocols during the network start-up within a PROFINET network.

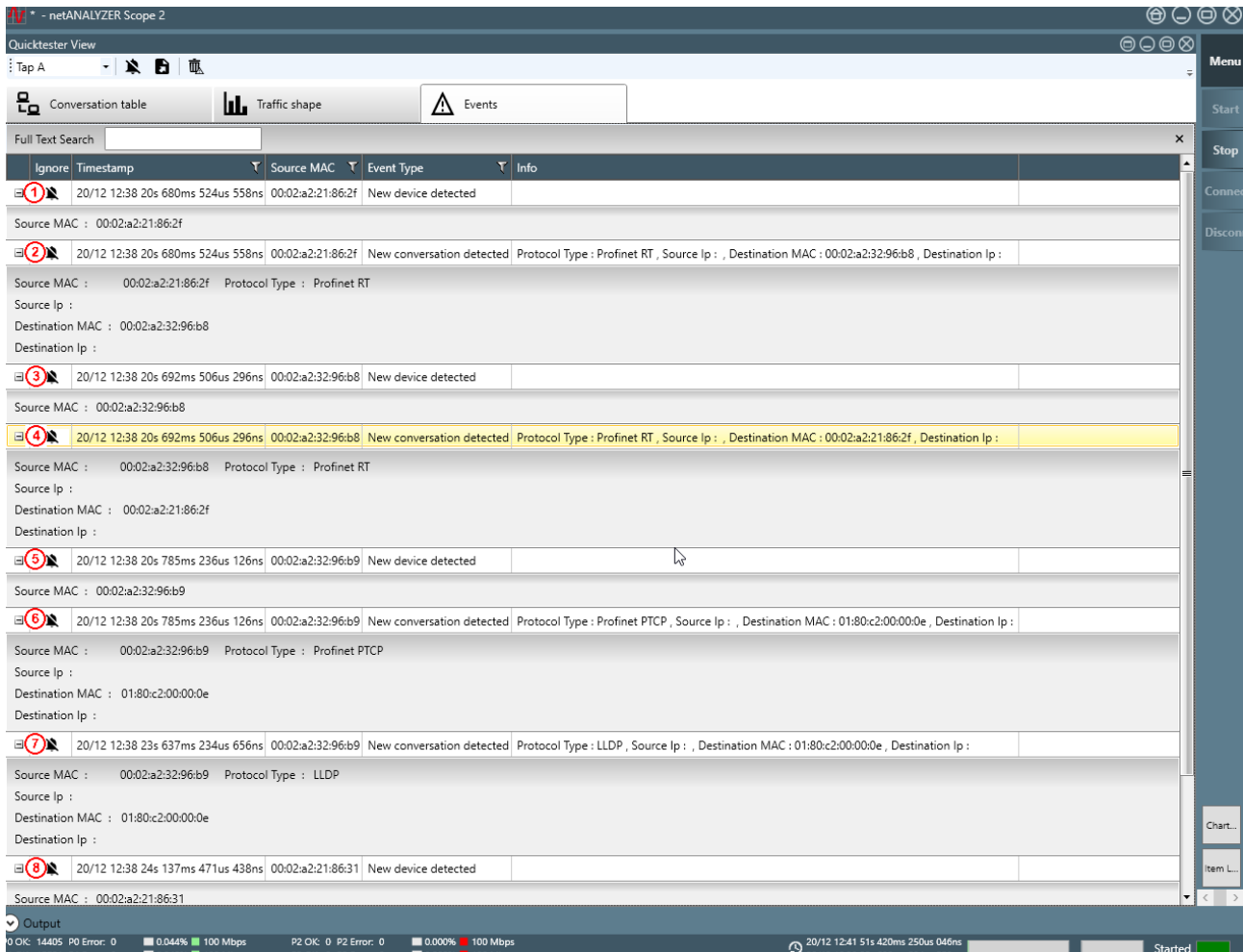

Figure 186: Example: Event log of the communication between various partners using various protocols in a PROFINET network

For the identification of the single devices, the MAC addresses of the master and slave devices within the network should be known prior to the analysis. In the following example, the following devices and MAC addresses are involved:

Device	MAC address
1. MAC address of the master	00:02:a2:21:86:2f
2. MAC address of the master	00:02:a2:21:86:31
1. MAC address of the slave	00:02:a2:32:96:b8
2. MAC address of the slave	00:02:a2:32:96:b9
Protocol-specific Multicast MAC Address	01:80:c2:00:00:0e

Table 84: MAC addresses of the Master- and Slave-devices within the network

In detail, the following nine events can be observed within this event log.

1. Detection of a new MAC address:
Device with Source-MAC 00:02:a2:21:86:2f ((1. MAC address of Master detected)
2. Detection of a new conversation:
Device with Source-MAC 00:02:a2:21:86:2f(Master) communicates via PROFINET RT with device with Destination-MAC 00:02:a2:32:96:b8(Slave)
3. Detection of a new MAC address: Device with Source-MAC 00:02:a2:32:96:b8 (1. MAC address of slave) detected
4. Detection of a new conversation:
Device with Source-MAC 00:02:a2:32:96:b8 (Slave) communicates via PROFINET RT with device with Destination-MAC 00:02:a2:21:86:2f (Master)
5. Detection of a new MAC address:
Device with Source-MAC 00:02:a2:32:96:b9 (2. MAC address of slave) detected
6. Detection of a new conversation:
Device with Source-MAC: 00:02:a2:32:96:b9 (Slave) communicates via PROFINET PTCP with Multicast Destination MAC 01:80:c2:00:00:0e.
7. Detection of a new conversation:
Device with Source-MAC: 00:02:a2:32:96:b9.
8. Detection of a new MAC address:
Device with Source-MAC 00:02:a2:21:86:31(2. MAC address of master) detected
9. Detection of a new conversation:
Device with Source-MAC: 00:02:a2:21:86:31(Master) communicates via LLDP with Multicast Destination MAC 01:80:c2:00:00:0e.

10.9.2 Functions of quicktester view

The quicktester view offers the following functions:

- Open ignore list
- Export to spreadsheet software such as Microsoft Excel®
- Delete event log (all other recorded data remain unchanged)
- Selection between the TAPs of the netANALYZER

10.9.2.1 Ignore list

The ignore list (list of event types not to be taken into account) offers the possibility to define criteria for the identification of unwanted events not to be displayed within the event log.

Structure of ignore list

The ignore list has the following structure

Column #	Column	Meaning
1	Remove	Button (Trash can icon) for removing the current table row
2	Event type	Event type You can find a list of supported event types in <i>Event log</i> [▶ page 230]
3	The alarm type	The alarm type
4	The alarm class	The alarm class
5	Source MAC	Source MAC address
6	Destination MAC	MAC address of the data destination
7	The user structure Id	Unique identification of user structure

Table 85: Structure of ignore list

The columns **Alarm Type**, **Alarm Class** and **User Structure ID** are only used in the structure of the ignore list if the selected event type is **PROFINET Alarm detected**.

Opening the ignore list

In order to open the ignore list, proceed as follows:

- Click to  within the row of your choice.
- The ignore list (i.e. the list of event types not to be taken into account is displayed).

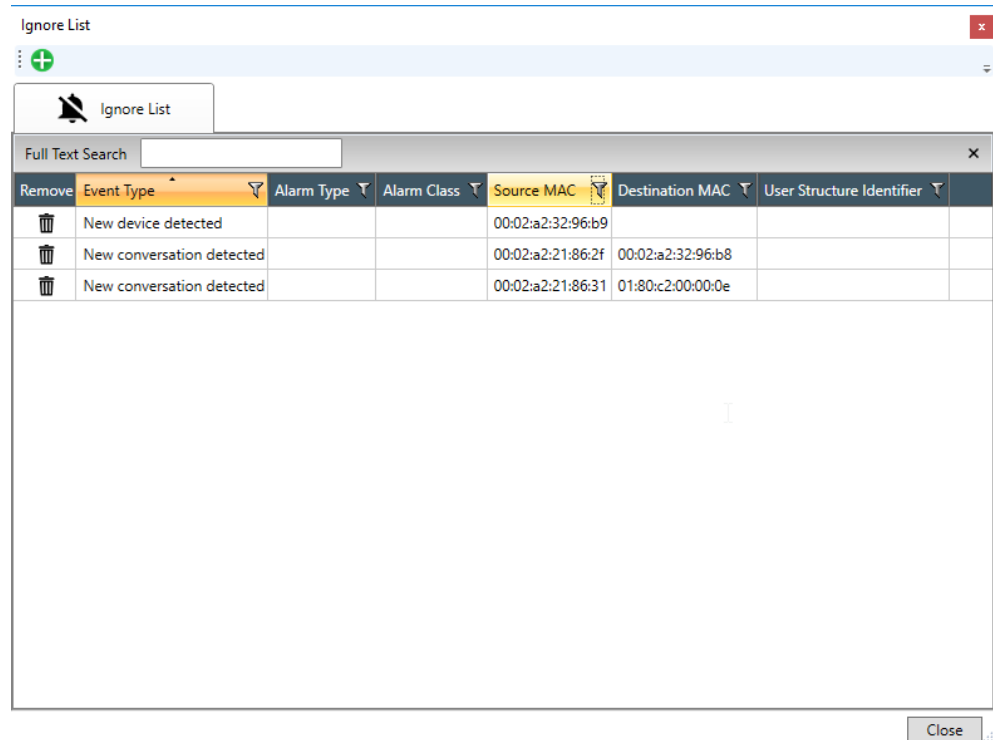

Figure 187: Ignore list

Full-text search

Proceed as follows in order to find a term occurring in the ignore list using the full-text search function:

- Specify the term to be searched for into the field **Full-text search**.

Adding entries to the ignore list

If you want to transfer an entry from the event log into the ignore list, you can accomplish this most simply via clicking at the button "Ignore" left of the row of the according entry, see *Event log* [▶ page 229].

Proceed as follows:

- Click at the green plus symbol at the upper edge of the list window.
- The dialog **Ignore Event** is opened. Depending on the selected event type, it has a different number of parameters.
- Select the event type of your choice.
- For all required parameters, specify the values to be used (see below).
- ⇒ The entry is added to the ignore list. All parameters are sorted into the according column of the table.

For the event types

- New MAC address detected
- IP Address changed
- Name of Station changed
- Subnet mask has changed

the dialog **Ignore event** looks like:

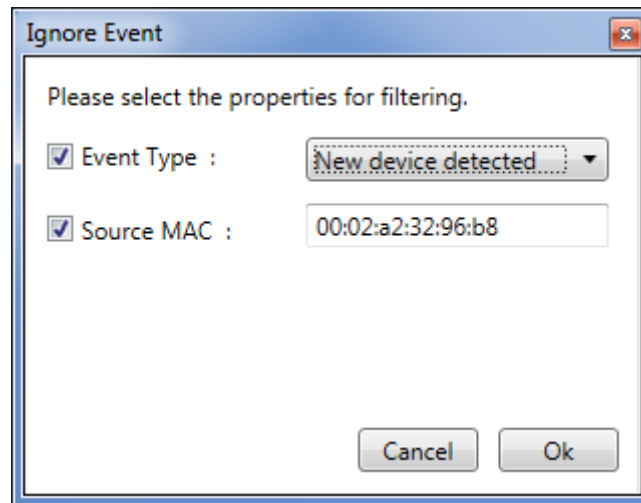

Figure 188: Dialog "Ignore event"

Both of the following parameters can be used for filtering:

- The event type
- The source MAC address

For the event types

- New conversation detected
- Device startup detected
- Unexpected cycle counter
- DCP Ident Request
- Jitter threshold exceeded

the dialog **Ignore event** looks like:

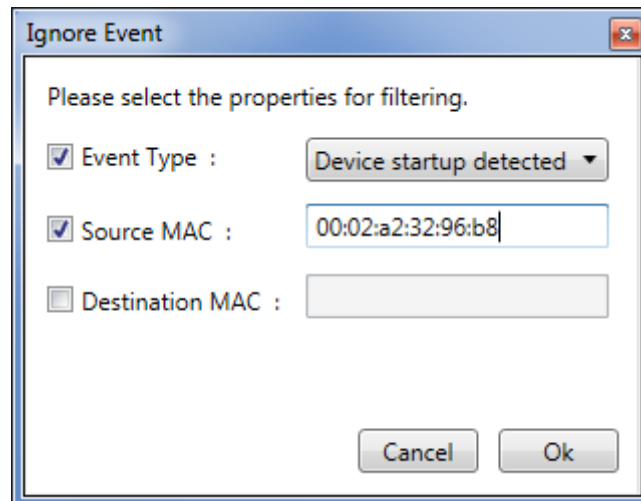

Figure 189: Dialog "Ignore event"

The following three parameters can be used for filtering:

- The event type
- The source MAC address
- The destination MAC address

For the event type

- PROFINET Alarm detected

the dialog **Ignore event** looks like:

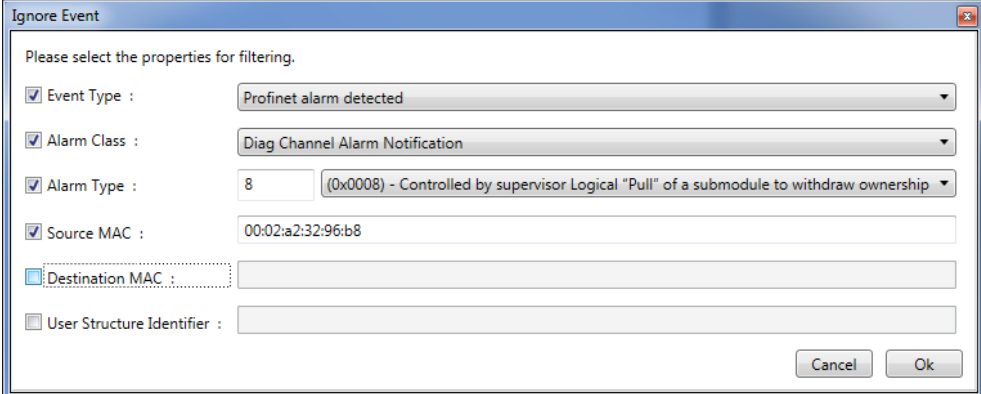

Figure 190: Dialog "Ignore event"

The following parameters are allowed for filtering

- The event type
- The alarm class
- The alarm type
- The source MAC address
- The destination MAC address
- The user structure Id

All of the following parameters are equipped with an additional checkbox at the left side of the dialog allowing to activate and deactivate them. If they are activated, parameter input conforming with the applicable rules is required. As long as no rule-conforming parameter input has happened, the input field is framed in red color and the Ok button is deactivated if this applies to at least one of the displayed parameters. Activated parameters are transferred to the ignore list.

The event type

For the event type the following options apply:

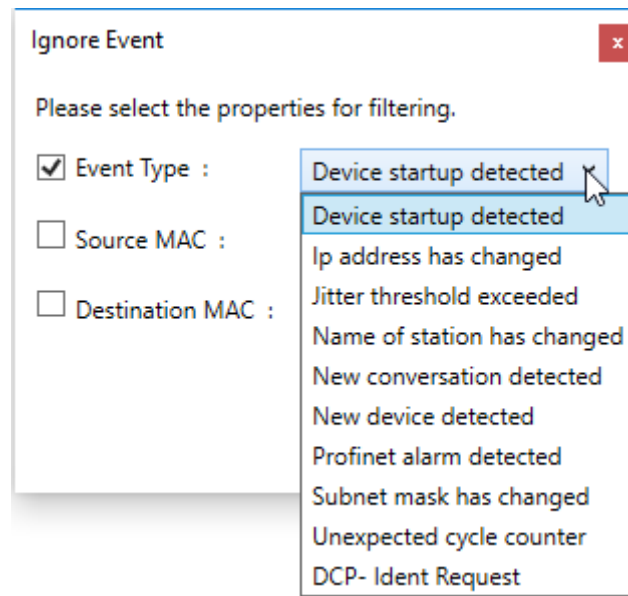

Figure 191: Dialog "Ignore Event" with expandable list for the event type

The alarm class

The selectable alarm classes for events of the type *PROFINET Alarm detected* are defined by the PROFINET specification.

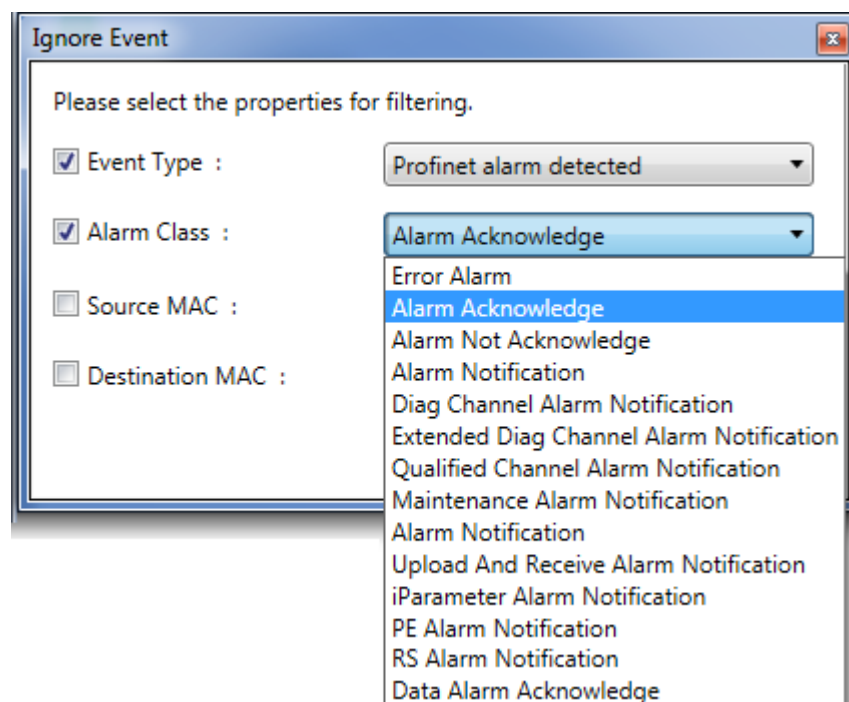

Figure 192: Alarm classes

The alarm type

The selectable alarm types for events of the type *PROFINET Alarm detected* are defined by the PROFINET specification.

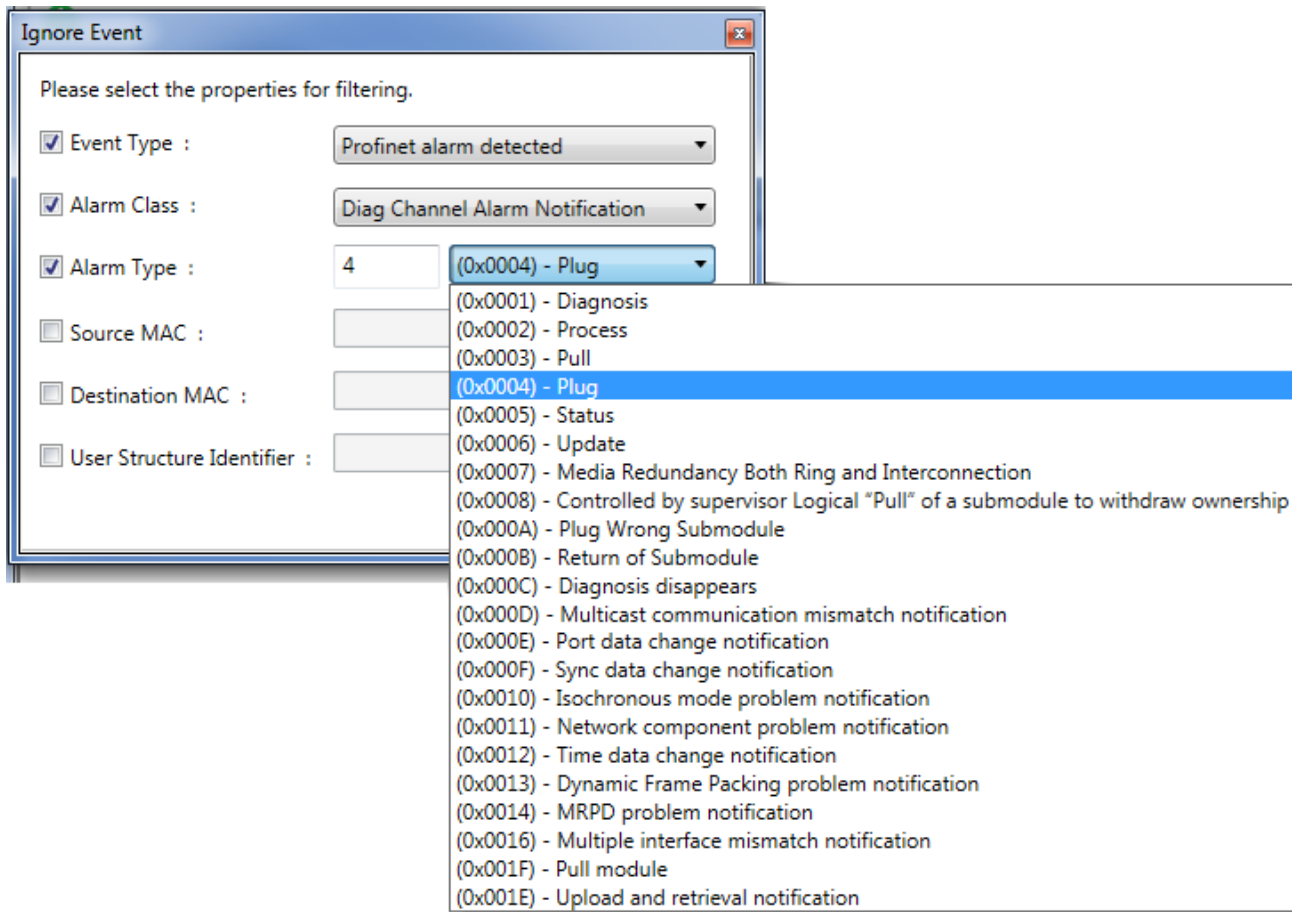

Figure 193: Alarm types

The source MAC address

Enter the MAC address of the network participant (Source MAC address) into this field. This address has to conform to the rules for MAC addresses (6 two-digit hexadecimal values separated from each other by colons).

The destination MAC address

Enter the MAC address of the communication partner of the network participant (Source MAC address) into this field. This address has to conform to the rules for MAC addresses (6 two-digit hexadecimal values separated from each other by colons).

The user structure Id

Specify a non-negative integer value in the range between 0 and 65535 (hexadezimally: 0 ... 0xFFFF) here.

Entfernen von Einträgen

In order to remove an entry of the ignore list (for instance, a row).

- Within the respective entry, click at **Remove** .
- ⇒ The entry is removed then.

Closing the ignore list

In order to close the ignore list, proceed as follows:

- Click at **Close**
- ⇒ The ignore list (i.e. the list of event types not to be taken into account is closed).

10.9.2.2 Data export into a spreadsheet such as Microsoft Excel

The acquired data can also be exported to an *.xlsx file for use in Microsoft Excel® or other similar spreadsheet software.

In order to export the acquired data into an *.xlsx file, proceed as follows:

➤ Click at .

⇒ The Excel export dialog is displayed:

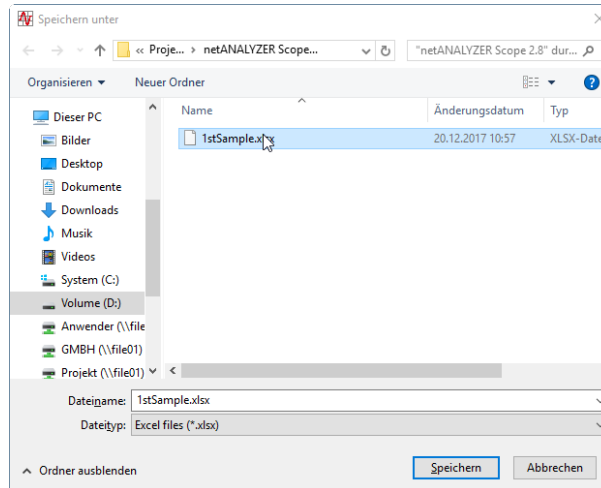

Figure 194: Excel export dialog

➤ At file name, specify the name of the file to be created in the *.xlsx format and click at **Speichern**.

⇒ The *.xlsx file with the acquired data is created using the desired name and can now be opened using Microsoft Excel® or another spreadsheet software of your choice supporting the *.xlsx format.

The exported *.xlsx file contains the following register cards:

- Conversation table
- Frames pro Sekunde
- Oktetts pro Sekunde
- Prozent pro Sekunde
- Frames pro Minute
- Oktetts pro Minute
- Prozent pro Minute

10.9.2.3 Delete event list

The entries within the event list can be deleted, all other recorded data remain unchanged.

For instance, this is useful to remove detected events from the first start-up of the plant and detect new unforeseen events during the plant being in a stable state.

In order to delete the event log, proceed as follows:

➤ Click at .

⇒ A security request box appears:

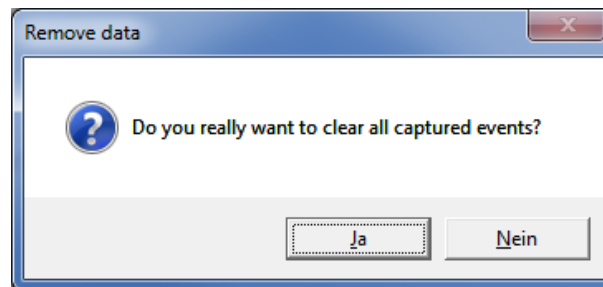

Figure 195: Security request box before deleting the acquired events

⇒ If you respond with **Ja**, all acquired events are deleted.

⇒ If you respond with **Nein**, nothing will change.

10.9.2.4 Selection between the TAPs of the netANALYZER

A selection list allows either to select data from TAP A for display or from TAP B.

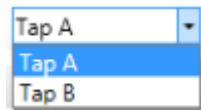

11 Examples for the possibilities of the timing analysis

Pay attention to the following notes:



Note:

Normally certain cyclical frames are fundamental for the timing analysis, e.g. the Sync frame at PROFINET or MDT0 at Sercos. It is of importance that only these frames are brought to the timing analysis. Therefore before the start of the analysis a corresponding filter must be set, which prefilters possible acyclic or additional cyclical frames and exclusively lets through the frame to be analyzed.



Note:

Caused by the auto crossover function used by many RTE systems, the pin assignment of port 0 and 1 or port 2 and 3 can change from test run to test run.

Cycle Time Measurement

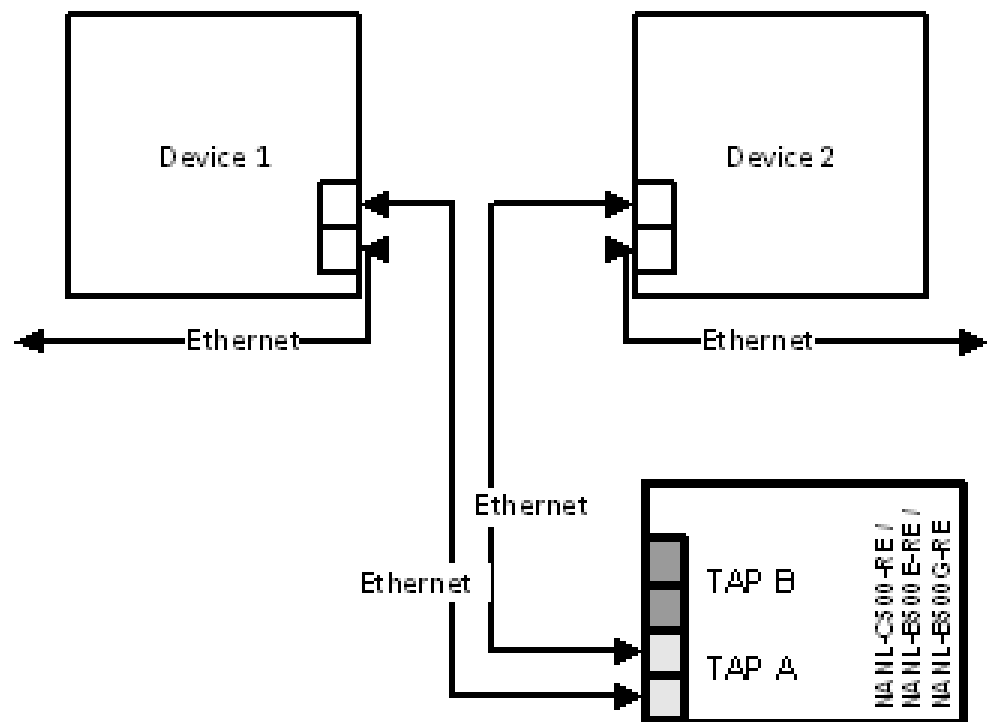

Figure 196: Use case 1 - Example cycle time measurement

For the cycle time measurement, it is sufficient to insert one TAP of the analyzer card NANL-C500-RE or the analyzer device NANL-B500E-RE or NANL-B500G-RE into transmission distance. Here the differences between two successive frame times are formed, and gives the cycle time as a result. In the port selection as start and as destination port correspondingly the same port must be selected.

For Cycle Time Measurement, select *Jitter / Cycle time*.

Forwarding time measurement

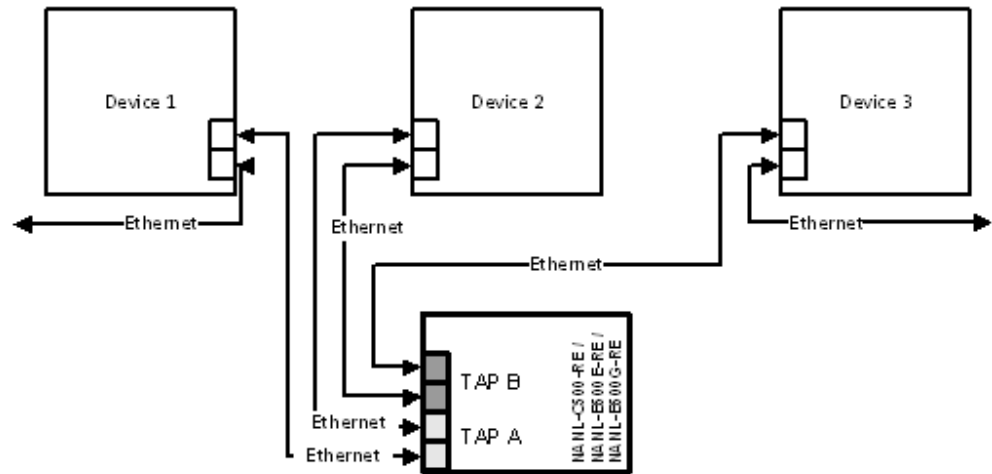

Figure 197: Use case 2 - Forwarding time measurement

For the forwarding time measurement the analyzer card NANL-C500-RE or NANL-B500G-RE must be inserted before and behind the device to be examined. Here the time difference between the frame coming in on the one side of the device is measured up to the next frame on the other side of the device. The port selection correspondingly must be carried out from a port of the first TAP to a port of the second TAP: Difference of port 0/1 to port 2/3 or for measurement to the opposite direction port 2/3 to port 0/1.

For forwarding time measurement, select the type *Delay/Answertime*.

Stack forwarding time measurement

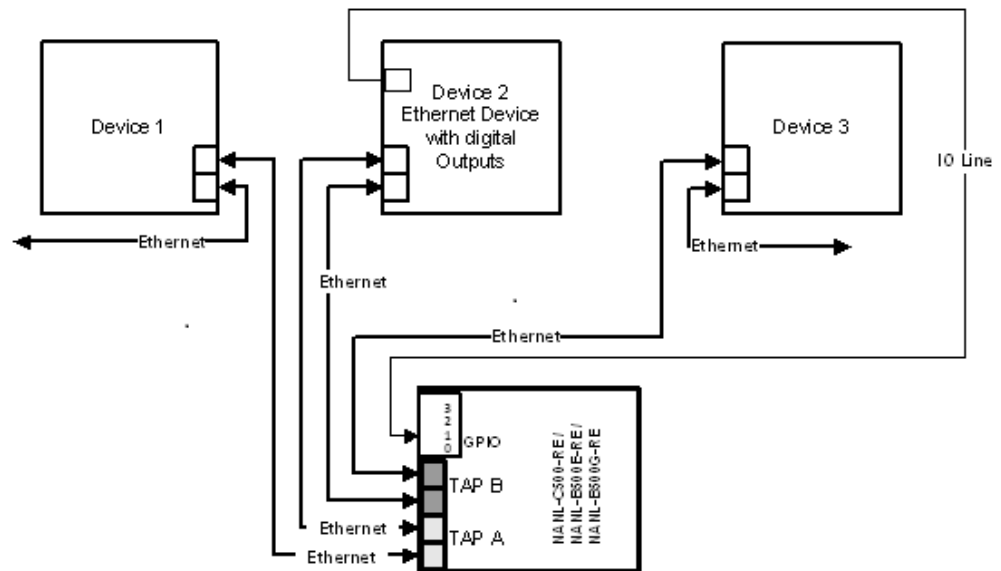

Figure 198: Use case 4 – Measurement of device forwarding time – Example stack forwarding time measurement

For stack operating-time measurement the difference between a port of the Ethernet channel and a GPIO can be formed. Here, e. g. a cyclical process data frame on port x becomes supervised as well as the appearance of a digital switching event on GPIO y after this frame was processed in the software stack.

For stack forwarding time measurement, select type *Delay/Answertime*.

Response-time measurement

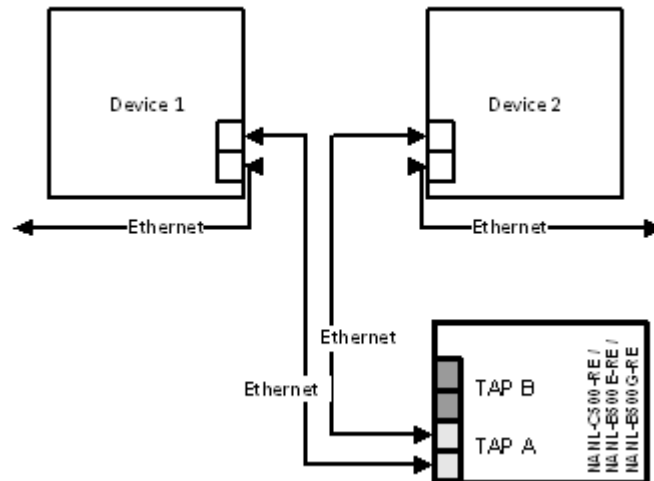

Figure 199: Use case 1 - Example response-time measurement

For response-time measurement the difference in time between two different ports on the same TAP is measured. Here, for example, the incoming frame on port 0 is recorded, and the outgoing response frame on port 1.

One effect of the port interchanging is, that for wrongly selected ports the response time is measured incorrectly, because the measurement values are taken from the wrong ports.

For response-time measurement, select type *Delay/Answertime*.

12 Tools

12.1 PCAP export

netANALYZER Scope offers the possibility to export captured Ethernet traffic data. Data export is performed in the widely used *.pcap format which is also supported by various network analysis tools, for instance Wireshark®.

In order to export captured Ethernet data in the *.pcap-Format, proceed as follows:

- Open the side menu and select register card *Tools*.
- The side menu opens:



Figure 200: Menu pane Tools

- Click at *PCAP exportieren*.
- The export dialog is opened. It looks like this:

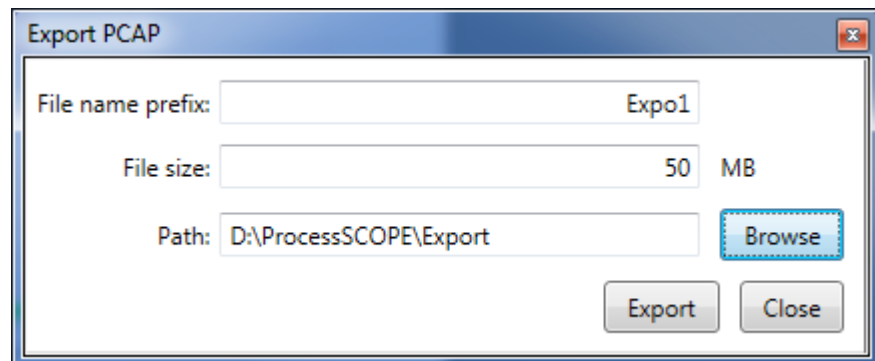

Figure 201: PCAP Export

- Specify a prefix for the file names of the *.pcap files to be written.
- Specify the maximum size of the *.pcap files to be exported. If the data exceeds this size automatically a new file is used and the file names are numbered.
- Specify the path where the *.pcap files shall be written. You may use the Browse Button to select the desired directory.

- Click at *Exportieren*.
- ⇒ If a file with the chosen file name already exists in the directory specified at *Path*, then the following informative message appears:

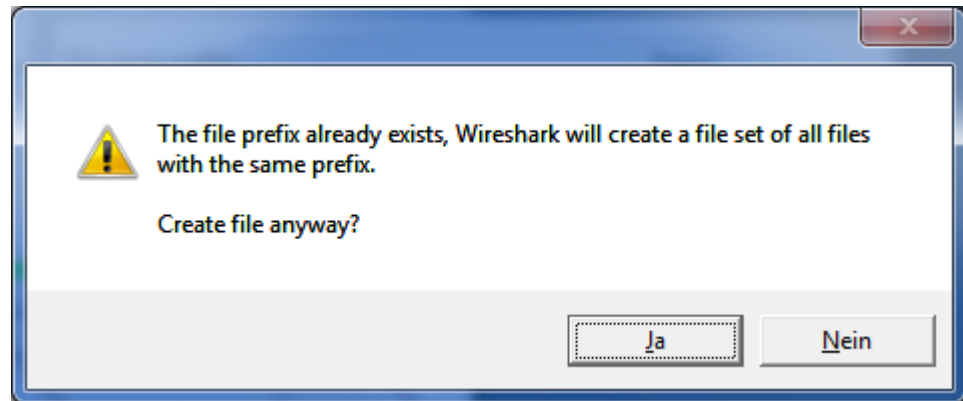

Figure 202: PCAP Message "File prefix already exists"

- ⇒ A progress bar appears until the *.pcap files containing your measured data have completely been written into the specified path.
- ⇒ The export dialog still remains opened.
- If you want to close it, click at the *Close* button.

12.2 PCAP import

netANALYZER Scope offers the possibility to import captured Ethernet data which have been stored in *.pcap format. However, you need a special licence (8582.070 LIC/SCP/PCAP) to use this import feature.

Import *.pcap files

1. In order to import *.pcap files containing captured Ethernet data, proceed as follows:
 - Open the side menu and select register card *Tools*.
 - The register card *Tools* opens:



Figure 203: Register card „Tools“

- Click at *Import PCAP*
- The import dialog is opened. It looks like this:

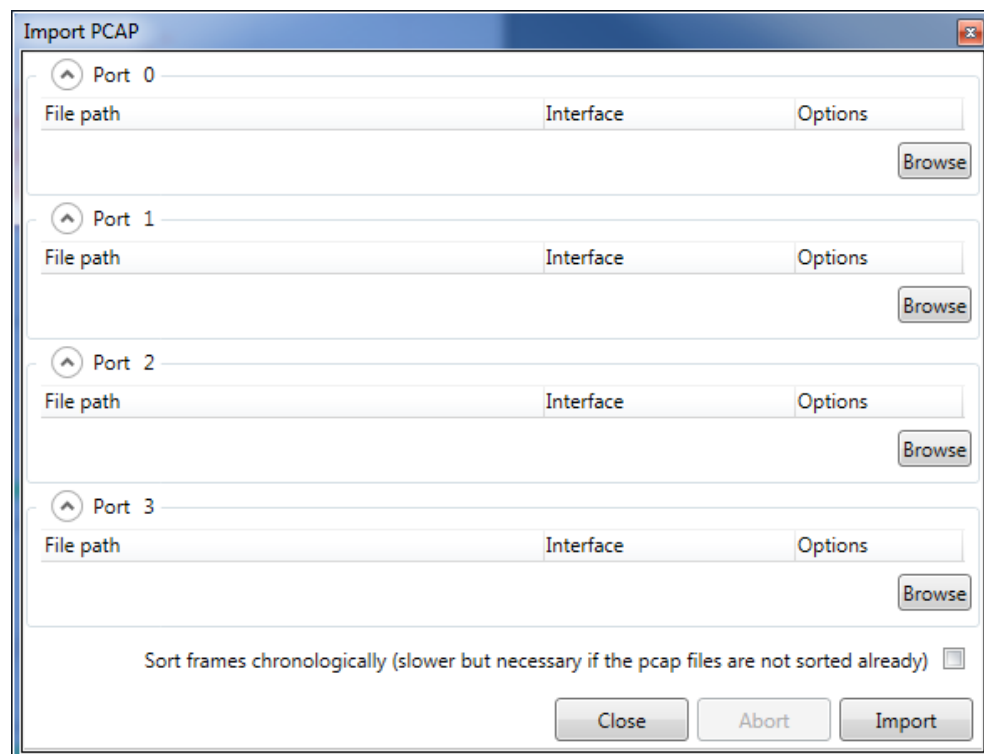

Figure 204: PCAP Import

Import dialog

The import dialog contains four lists for the four ports (port 0 ... port 3). It provides separate *Browse* buttons for these four ports and therefore allows to specify *.pcap import files separately for each port. In this way, single *.pcap files can be imported onto single netANALYZER receive ports as if they really would have been physically received at a specific netANALYZER port.

When importing EtherCAT data the data streams for input and output direction of the EtherCAT network must be imported on two separate ports of a TAP (such as port 0+1 or port 2+3) in order to achieve correct operation of the automatic direction detection and the decoding of the process values.

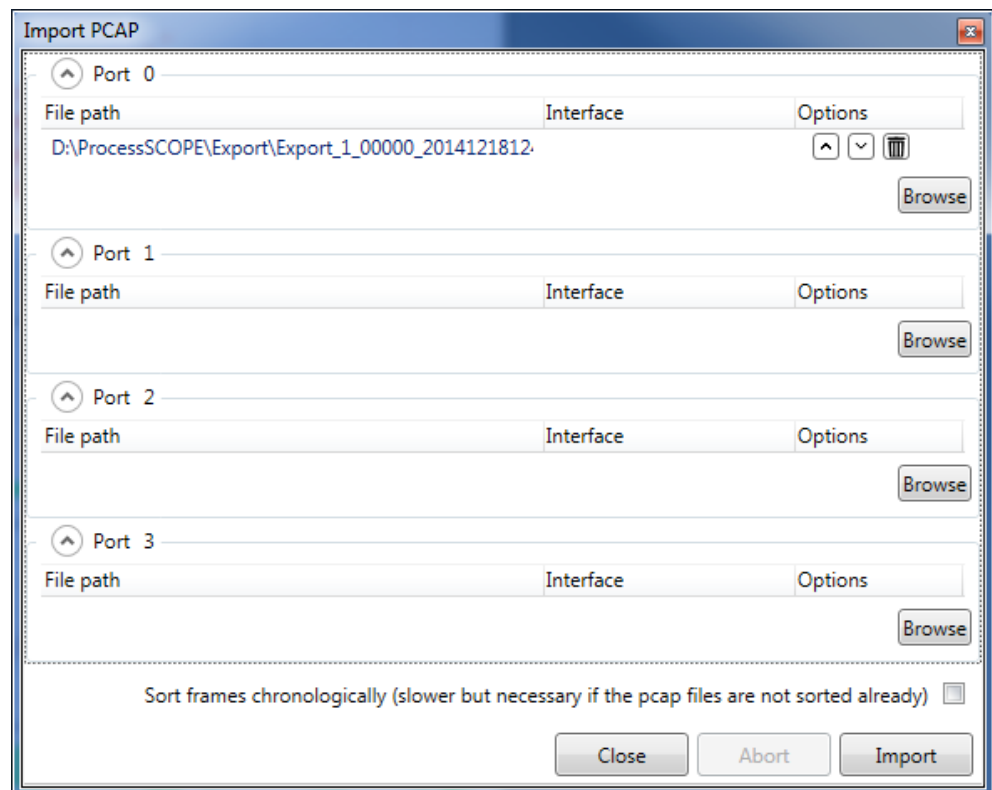

Figure 205: PCAP Import

Each line representing an import file is accompanied by three icons:

Icon	Meaning
	Move file one line up
	Move file one line down
	Delete file from list

Table 86: Icons for file import

Add a file to the lists of either a single port or all ports

- Click at the desired *Browse* button to open a file selection dialog and select your *.pcap file for import there.
- ⇒ After clicking at *Open*, the following happens.
- ⇒ If the *.pcap file contains data for multiple ports, the following message appears:

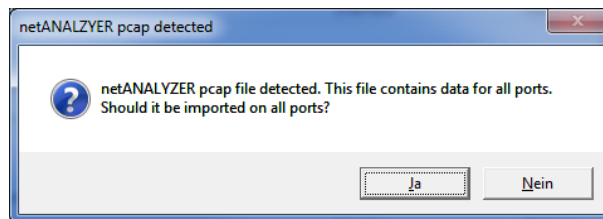

Figure 206: Import message "Data for multiple ports"

- ⇒ If you answer *Yes*, all ports will be updated with the imported data from the *.pcap file.
- ⇒ If you answer *No*, only the selected port will be updated with the imported data from the *.pcap file.
- ⇒ The file path is listed in the list below the selected port.

Import of all selected files

To import all selected files, proceed as follows:

- Click at button *Import*.
- ⇒ The following message will appear issuing a warning against possible loss of data by overwriting:

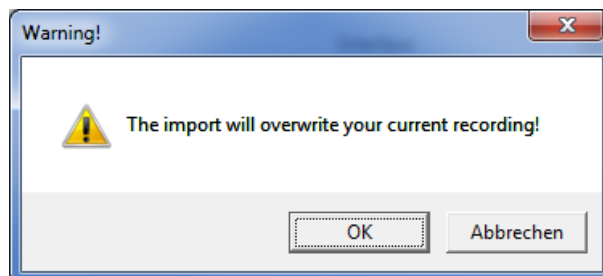

Figure 207: Import message "Overwrite on import"

- If the current data in netANALYZER Scope may be overwritten, you can continue by clicking at *OK*.
- ⇒ If the used netANALYZER device has a suitable license, the files are imported into netANALYZER Scope.

Otherwise, the following message appears:

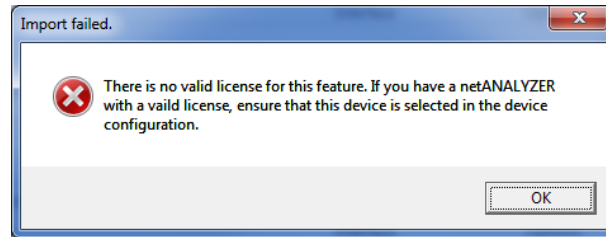

Figure 208: Import message "Import failed"

In this case, we recommend to acquire the necessary license (Part no. 8582.070 LIC/SCP/PCAP), and to repeat the steps described here.

12.3 PDF report

The PDF report allows you to print data from the PROFINET quicktester of the loaded project into a PDF file.



Figure 209: Menu pane "Tools"

Report wizard

The report wizard supports you to set the scope for the report. All texts, one logo and signees are optional.

Title page of the report: You can specify one logo, the text for the header (title with up to 100 characters), the text for plant specific information (up to 500 characters) and commissioning information for the title page.

Data scope: You can select for Tap A and Tap B separately whether the device overview, conversation table, and/or the event list of the loaded project will be printed into the PDF file.

End of the report: you can enter the text for a comment (up to 500 characters). If the report is to be signed then you can enter the names of the signees.

As long as the report wizard is opened, you can correct your input or adapt your input for additional PDF report. The netANALYZER Scope software saves the input of the report wizard in the project file.

13 Correct errors

13.1 Error Messages

Error message	<p>The following error message is displayed in the <i>Message output area</i> [▶ page 31]:</p> <pre>0xC066000B NETANA_CAPTURE_ERROR_NO_HOSTBUFFER No free DMA buffer available. Host is too slow to handle data efficiently.</pre>
Explanation	<p>The performance of the PC to which the netANALYZER device is connected is not sufficient for the permanent recalculation of the triggers.</p>
Action/Remedy	<p>Use a PC with more performance. Enlarge the cycle time. Try to use less complex trigger conditions. Check whether the hard disk drive of the PC is sufficiently powerful to store the amount of data to be recorded The theoretical maximum load is 50 MByte/s.</p>
Error message	<p>The following informative message only occurs when trying to connect to PROFINET:</p>  <p>Error Message Box: Change in PROFINET Bus Configuration</p>
Explanation	<p>The netANALYZER was not connected to the PROFINET line. If changes in bus configuration have occurred in the mean time, these could not be detected automatically. If you are sure, that the bus configuration has not been changed, you can answer this question with “No” and the currently used configuration remains active.</p> <p>If the bus configuration changes, repeat recording the PROFINET bus communication start-up. In this case answer with “Yes” and start up the bus again.</p>
Action/Remedy	<p>Reanalyze the startup process of the PROFINET network. For more details, see section Startup of PROFINET Communication.</p>
Error message	<p>The following error message is displayed after opening a project file:</p> 
Explanation	<p>Not enough free memory of the HDD available.</p>
Action/Remedy	<p>Increase free memory on your HDD and increase the setting for option “HDD”). Open the file again.</p>

Table 87: Error messages

13.2 Other error situations

Error message	Either missing devices or no devices at all displayed within the Item View at PROFINET
Explanation	The startup of the PROFINET communication could not be analyzed completely.
Action/ Remedy	The startup of the PROFINET communication needs to be analyzed again. See section <i>Start-up of PROFINET communication</i> [▶ page 79].
Error message	Display of Graph View is totally empty, there are even no axes displayed.
Explanation	This behavior indicates missing support for DirectX Version 9 by either the used graphics adapter (card/on board) or the graphics driver.
Action/ Remedy	<p>Deinstall DirectX. Subsequently install DirectX Version 9 or higher.</p> <p>Check, whether the graphics driver of your hardware really supports DirectX Version 9. If necessary, install a new graphics driver with DirectX Version 9 support.</p> <p>If both steps mentioned before do not succeed, exchange the graphics hardware including graphics driver by such items which explicitly support DirectX Version 9.</p>

Table 88: Other error situations

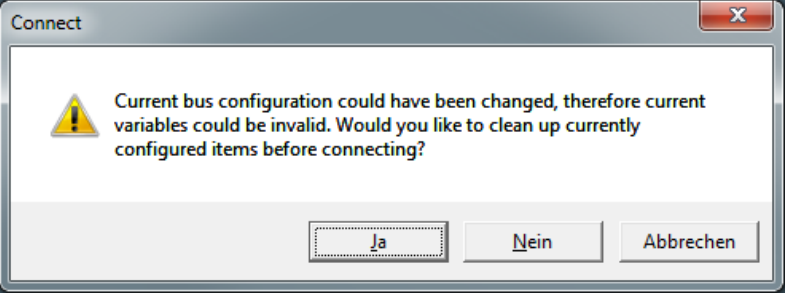
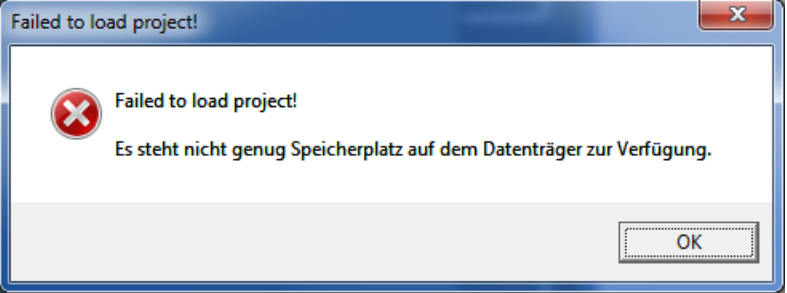
13.3 Chart data are displayed incorrectly for EtherCAT

Error message	In the chart view, a signal contains many red triangles that indicate a wrong EtherCAT working-counter (WKC), even though communication is working well and all slaves are on-line.
Explanation	This may happen due to a failure in communication direction detection.
Action/ Remedy	<p>Normally, netANALYZER Scope is able to detect the input or output data direction by evaluating bit 2 of the EtherCAT frame's source MAC address. If this bit is 0 the frame is assumed to be sent in output direction. If this bit is 1, is is assumed to be the input data frame.</p> <p>If the <i>processed flag</i> does not differ for the input or output data direction, the software tries additionally to recognize the direction using the working counter values. If this is not possible, a manual configuration of the direction is required.</p> <p>A blue triangle means that automatic recognition of the direction was not clearly possible and a manual configuration of the direction is required.</p>

Table 89: Chart data are displayed incorrectly for EtherCAT

This is working in may environments, especially Beckhoff and Hilscher ASICs support that feature. See the definition of the forwarding rule:

Table 20: Register ESC DL Control (0x0100:0x0103)

Bit	Description	ECAT	PDI	Reset Value
0	<p>Forwarding rule:</p> <p>0: EtherCAT frames are processed, Non-EtherCAT frames are forwarded without processing</p> <p>1: EtherCAT frames are processed, Source MAC Address is changed (SOURCE_MAC[1] is set to 1 – locally administered address), Non-EtherCAT frames are destroyed</p>	r/w	r/-	1

Figure 210: Register ESC DL Control (0x0100 to 0x0103)

Nevertheless, in some environments MAC address comparison is not possible, as source MAC address of input and output direction frames do not differ in bit 2. This may be if the netANALYZER is not connected between master and first slave, but somewhere else in the line. Or if the slaves do not follow the forwarding rule definition.

A miss-interpreted traffic due to enabled automatic direction detection is shown in the following example:

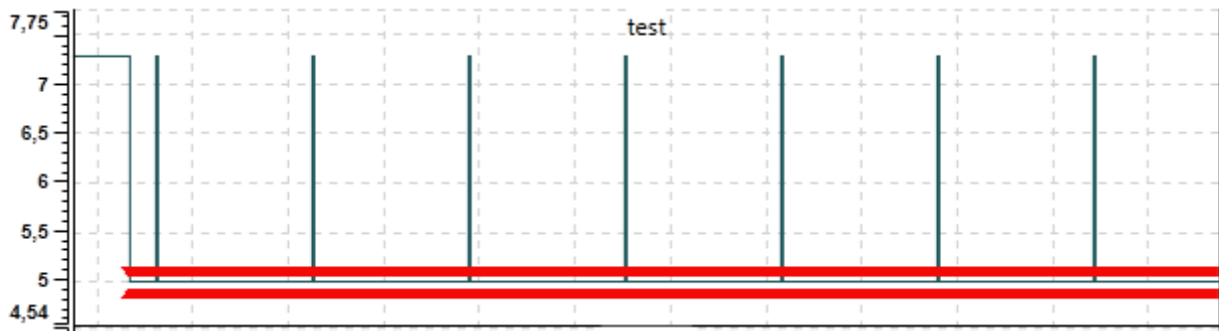

Figure 211: Example: miss-interpreted traffic due to enabled automatic direction detection

By changing the automatic direction detection off, the user is able to select manually which EtherCAT frames for the appropriate direction are received on which port. Note, that due to EtherCAT's auto-crossover functionality this port assignment may change between link state changes on the EtherCAT line.

You can manually set the correct data direction using the network wizard, see *Edit network* [▶ page 94].

By selecting the correct direction setting the red triangles in the chart view disappear and data values are correctly interpreted.



Figure 212: Example: Correct display

For comparison, selecting the wrong manual direction would result in keeping the red triangles (wrong WKC) as the expected WKC for the selected direction does not match the received WKC for the wrongly selected frames.

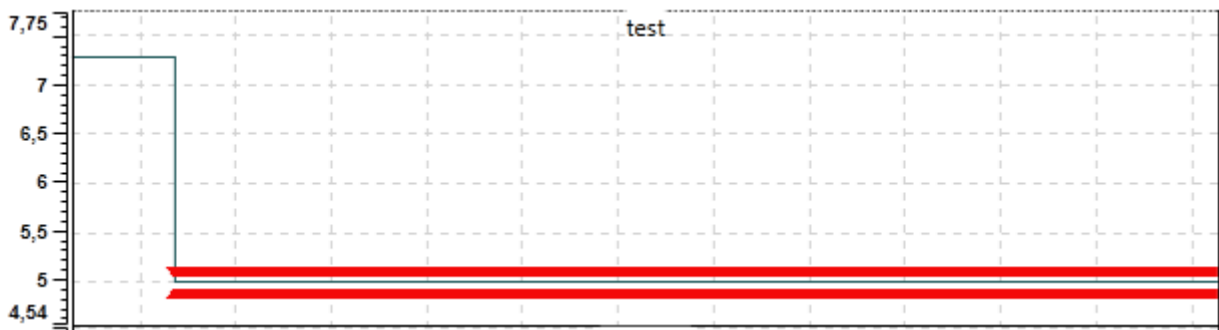

Figure 213: Example: wrong manual direction

14 Appendix

14.1 Addressing of devices across multiple CIP networks using port segments

Port segments provide a simple method for addressing devices across multiple CIP networks. In this context, these CIP networks are also denominated as routed CIP networks, for instance EtherNet/IP networks. In this way, a port segment describes a "door" (denominated as port), by which the device can be left and contains an instruction, where the rest of the way will lead to. For the structure of a port segment, the following rules apply:

1. A port segment is characterized by its first three bits having been set to zero. Therefore, all port segments contain a port identifier and a link address.
2. The fourth bit decides whether an extended link address format shall be used (Bit set), or not (Bit not set). EtherNet/IP always uses this extended link address format. So for EtherNet/IP, this bit is always set to 1.
3. The bits #5 up to #8 contain the port identifier. this is a value between 0 and 15 uniquely identifying the port.
4. The second byte contains the length of the link address (byte count).
5. An optional Extended Port Identifier may follow. It is only needed in case of a device defining more than 14 ports.
6. Finally, the link address itself follows (with a length in byte that corresponds to the value specified within the second byte).

Simple example of port segments

To express how to go to EtherNet/IP port #3 and then to proceed to the device with the IP address 10.11.4.1, use the following representation:

```
[13]
[09]
[31] [30] [2E]
[31] [31] [2E]
[34] [2E] [31]
[00]
```

The values are assigned in this way:

Value	Meaning
[13]	Port segment with extended size format of link address . Port #3
[09]	Specification: here the link address has a size of 9 byte
[31] [30] [2E] [31] [31] [2E] [34] [2E] [31]	IP address 10.11.4.1
[00]	Filling byte

Table 90: Example

Example of port segments with multiple network transitions

Looking at port segments with multiple network transitions, such segments are simply concatenated

Example:

```
[13] [09] [31] [30] [2E] [31] [31] [2E] [34] [2E] [31] [00] [02] [06] [05] [20]
```

This means:

Go to port #3, then to IP address 10.11.4.1, in this device to port #2, then proceed to node 6, in this device to port #5 and finally to node 32.



Note:

A concise description concerning the addressing of devices across multiple connected networks using port segments can be found within Appendix C of the CIP specification.

14.2 References

This document refers to the following documents:

1. PROFINET specification:
PROFIBUS International: Technical Specification for PROFINET IO: Application Layer services for decentralized periphery, Version 2.3Ed2MU3, March 2016, Order No. 2.712, English.
PROFIBUS International: Technical Specification for PROFINET IO: Application Layer protocol for decentralized periphery, Version 2.3Ed2MU3, March 2016, Order No. 2.722, English.
2. EtherCAT specification: IEC 61158 Part 2-6 Type 12 documents, also available for ETG members as documents ETG.1000.2 to ETG.1000.6
3. EtherCAT Network Information, Specification, EtherCAT Technology Group, Nuremberg, 2009 (ETG Document ID: ETG.2100 S (R) V1.0.0)
4. RFC 791, Internet Protocol; available at IETF (<http://www.rfc-editor.org/rfc/rfc791.txt>)
5. RFC 3330, Special-Use IPv4 Addresses, available at IETF (<http://www.rfc-editor.org/rfc/rfc3330.txt>)

See also:

1. Hilscher Gesellschaft für Systemautomation mbH:
User manual: netANALYZER devices, Installation, operation and hardware description,
Revision 21, 2018, Document ID: DOC091110UM21EN.
2. Hilscher Gesellschaft für Systemautomation mbH:
Installation guide, Software installation for netANALYZER devices,
Installing driver and analyzer software,
Revision 4, 2017, Document ID: DOC150201IG04EN.

List of figures

Figure 1:	Recording Scenario with netANALYZER Scope between Master and Slaves	14
Figure 2:	Typical Application - The communication between a device and its connection partners in a network should be analyzed	14
Figure 3:	Example representation physical TAP	15
Figure 4:	Time stamping when variables extend over multiple Ethernet frames	20
Figure 5:	Start menu netANALYZER Scope	22
Figure 6:	Language selection list	23
Figure 7:	Side menu	24
Figure 8:	Menu Pane „Views“	26
Figure 9:	Menu Pane Project	27
Figure 10:	Menu pane Tools	27
Figure 11:	Menu pane "Device assignment"	28
Figure 12:	Menu Pane Options	29
Figure 13:	Menu Pane About	30
Figure 14:	Message output area	31
Figure 15:	Frame statistics (without connection to netANALYZERdevice)	32
Figure 16:	Telegram and frame statistics (with connection to netANALYZER device)	32
Figure 17:	Menu "Device Assignment"	34
Figure 18:	Menu "Device assignment" (without device)	35
Figure 19:	Driver Information area	36
Figure 20:	Device information	36
Figure 21:	Configuration of frame filter	37
Figure 22:	Ports configuration	37
Figure 23:	Network speed	37
Figure 24:	GPIO configuration	38
Figure 25:	Input Mode	38
Figure 26:	Checkbox Enable high load capture mode	39
Figure 27:	Static IP configuration	41
Figure 28:	Menu „Options“	42
Figure 29:	Adjusting the buffer size	44
Figure 30:	Error message box "Ring buffer configuration failed"	44
Figure 31:	Selecting the recording medium	45
Figure 32:	Quicktester settings	46
Figure 33:	Buffer fill level indicator	47
Figure 34:	Workload indicator	47
Figure 35:	Dialog „Configuration of hardware filters"	48
Figure 36:	Dialog „Configuration of hardware filters" (complete)	49
Figure 37:	Context menu of filter table	55
Figure 38:	Example 2	57
Figure 39:	Menu pane Projects	61

Figure 40:	Start menu netANALYZER Scope.....	62
Figure 41:	Language selection list.....	62
Figure 42:	Dialog Box" Save Project"	64
Figure 43:	Menu pane Projects.....	65
Figure 44:	File selection dialog for loading the project file.....	66
Figure 45:	Start menu	66
Figure 46:	Language selection list.....	67
Figure 47:	File Selection Dialog for loading the Project File	67
Figure 48:	Error Message "Incompatible project"	68
Figure 49:	Error message box "Failed to load project"	68
Figure 50:	Structure of EtherCAT Datagram	73
Figure 51:	Signal directions in EtherCAT.....	74
Figure 52:	Keep current bus configuration.....	79
Figure 53:	Example : Triggering on PROFINET Communication Events	82
Figure 54:	Keep current bus configuration.....	84
Figure 55:	Menu Pane Views.....	91
Figure 56:	Register card EtherCAT configuration.....	92
Figure 57:	Selection list for filtering (expanded)	93
Figure 58:	Edit network.....	94
Figure 59:	First page of the Network wizard	95
Figure 60:	Second page of the Network wizard.....	96
Figure 61:	Safety message "Overwrite network configuration"	97
Figure 62:	Safety message on Delete Network	97
Figure 63:	Dialog "TAP settings"	98
Figure 64:	Selection list "Before slave"	99
Figure 65:	Context menu of the EtherCAT Master	101
Figure 66:	Dialog Add Slave - first page	101
Figure 67:	Dialog Add Slave - second page	102
Figure 68:	Context menu for EtherCAT Master	104
Figure 69:	Context menu for EtherCAT Slave	104
Figure 70:	Dialog Add Variable - first page.....	104
Figure 71:	Dialog Add Variable - second page	106
Figure 72:	Dialog Variable Wizard - second page (Normalization).....	108
Figure 73:	Sicherheitsabfrage bei Kontextmenü-Eintrag Remove.....	109
Figure 74:	Remove item	114
Figure 75:	Dialog Controller Wizard:.....	115
Figure 76:	Device wizard	116
Figure 77:	Device wizard - Edit device - Entry dialog	117
Figure 78:	Device wizard - Edit device - Display of device description.....	118
Figure 79:	Module wizard - Edit module	119
Figure 80:	Error Message Box "A module with same slot number already exists!"	120

Figure 81:	Module wizard - Edit module - Entry dialog	120
Figure 82:	Module wizard - Edit module - Display of module description	121
Figure 83:	Submodule wizard - Edit module - page 1	121
Figure 84:	Submodule wizard - Edit module - page 2	123
Figure 85:	Error Message Box "A submodule with same subslot number already exists"	124
Figure 86:	Variable Wizard - first page (Parameter)	125
Figure 87:	Dialog Variable Wizard - second page (Normalization)	126
Figure 88:	Dialog Variable Wizard - second page (Normalization)	126
Figure 89:	Remove an item	130
Figure 90:	Dialog Controller wizard	131
Figure 91:	Device wizard	132
Figure 92:	Port segment 1	134
Figure 93:	Port segment 2	135
Figure 94:	Port segment 3	135
Figure 95:	Module wizard - Edit module	136
Figure 96:	Error Message Box "A module with same slot number already exists!"	137
Figure 97:	Module wizard - Edit module - Page 2	137
Figure 98:	Module wizard - Edit module - Page 3	138
Figure 99:	Variable wizard - first page (Parameter)	140
Figure 100:	Dialog Variable Wizard - second page (Normalization)	141
Figure 101:	Context menu on top level of custom value filter tree	142
Figure 102:	Context menu on level 1 of custom value filter tree	142
Figure 103:	Add custom value filter - Dialog 1 - Filter name	143
Figure 104:	Add custom value filter - Dialog 2 - Filter definitions	143
Figure 105:	Add custom value filter - Dialog 2 - Filter definitions	144
Figure 106:	Add custom value filter - Dialog 3 - Extraction behavior and parameters	145
Figure 107:	Add custom value filter - Dialog 4 - Normalization	146
Figure 108:	New folder	148
Figure 109:	Import dialog	149
Figure 110:	Context menu on level 2 (filter level) of custom value filter tree	150
Figure 111:	Edit custom value filter- Dialog 1 - Filter name	151
Figure 112:	Edit custom value filter- Dialog 2 – Filter definitions	151
Figure 113:	Quicktester events in chart view	154
Figure 114:	Context menu entry at Network Timing	155
Figure 115:	Context menu at folder in Network Timing tree	155
Figure 116:	Dialog Edit variable - first page	156
Figure 117:	Dialog Edit variable - second page	156
Figure 118:	Type selection list	156
Figure 119:	Example (detect IP frames at port 0)	157
Figure 120:	Context menu entry at Network Rate	159
Figure 121:	Context menu at folder in Network Rate tree.	159

Figure 122:	Dialog Edit variable - first page.....	160
Figure 123:	Dialog Edit Variable - second page	160
Figure 124:	Dialog box Edit variable - Selection of the And operation.	165
Figure 125:	Dialog box Edit variable . Entry IP frame in selection list Type.	165
Figure 126:	Dialog box Edit variable - After specifying the first filter criterion IP frame is present.....	166
Figure 127:	Dialog box Edit variable - Specifying the second filter criterion Port equals 2,.....	166
Figure 128:	Dialog box Edit variable - After specifying the second filter criterion Port equals 2.....	167
Figure 129:	Frame quicktester.....	168
Figure 130:	Example of data recorder window (Chart View)	169
Figure 131:	Menu entry "Chart View"	170
Figure 132:	Display of items in the data recorder window	171
Figure 133:	Chart View after the assignment	172
Figure 134:	Export Dialog of the	174
Figure 135:	Timestamp Input Control with Marker.....	175
Figure 136:	Timestamp Input Control	175
Figure 137:	Search Dialog	176
Figure 138:	Selection List "Variable" (Example Contents).....	176
Figure 139:	Operator Buttons	176
Figure 140:	Value Field.....	177
Figure 141:	Selection list for data type	177
Figure 142:	Chart View with additional histogram display	178
Figure 143:	Buckets/Markers area of the Chart View window	182
Figure 144:	Chart type	183
Figure 145:	Option Points visibility.....	183
Figure 146:	Option Interpolation	184
Figure 147:	Option Linewidth.....	185
Figure 148:	Option Line pattern	185
Figure 149:	Option Point size	186
Figure 150:	Option String representation.....	186
Figure 151:	Color Selection	189
Figure 152:	Color Selection Box in Standard Mode.....	190
Figure 153:	Color Selection Box in Advanced Mode	191
Figure 154:	Notepad window	193
Figure 155:	Context menu of notepad view	193
Figure 156:	Safety message "Remove comment?"	194
Figure 157:	Trigger view (Example).....	195
Figure 158:	Window bar.....	196
Figure 159:	Trigger selection list (expanded)	196
Figure 160:	Error message Trigger configuration is not valid	198
Figure 161:	Configuration area (Original state)	200

Figure 162:	Field "Sampling"	200
Figure 163:	Configuration area with selected sampling time	200
Figure 164:	Safety request prior to deletion of trigger logic	201
Figure 165:	Sources Area	202
Figure 166:	Signaldefinitionstabelle	203
Figure 167:	Error Message appearing when trying to erase an already used variable	205
Figure 168:	Constant Definition Table	205
Figure 169:	Error Message appearing when trying to erase an already used Constant.....	207
Figure 170:	Functional Blocks Area	208
Figure 171:	Dialog box "Edit trigger block"	211
Figure 172:	Dialog box "Edit Watchdog block"	215
Figure 173:	Dialog box "Edit marker block"	216
Figure 174:	Dialog box "Edit GPIO-Block"	217
Figure 175:	Dialog box "Edit Snapshot block"	218
Figure 176:	Type mismatch error between signal and constant in comparison.....	219
Figure 177:	Type conflict message.....	219
Figure 178:	Type conflict in comparison	220
Figure 179:	Menu Pane Views.....	221
Figure 180:	Conversation table (compressed).....	222
Figure 181:	Filter dialog Vendor ID.....	223
Figure 182:	Conversation table (Second line visible)	225
Figure 183:	Conversation table.....	227
Figure 184:	Display of the time dependence of the protocol usage distribution in the network's data traffic.....	228
Figure 185:	Event log.....	229
Figure 186:	Example: Event log of the communication between various partners using various protocols in a PROFINET network.....	231
Figure 187:	Ignore list	234
Figure 188:	Dialog "Ignore event"	235
Figure 189:	Dialog "Ignore event"	235
Figure 190:	Dialog "Ignore event"	236
Figure 191:	Dialog "Ignore Event" with expandable list for the event type	237
Figure 192:	Alarm classes	237
Figure 193:	Alarm types.....	238
Figure 194:	Excel export dialog	240
Figure 195:	Security request box before deleting the acquired events.....	241
Figure 196:	Use case 1 - Example cycle time measurement	242
Figure 197:	Use case 2 - Forwarding time measurement.....	243
Figure 198:	Use case 4 – Measurement of device forwarding time – Example stack forwarding time measurement.....	243
Figure 199:	Use case 1 - Example response-time measurement.....	244
Figure 200:	Menu pane Tools.....	245

Figure 201:	PCAP Export	245
Figure 202:	PCAP Message "File prefix already exists"	246
Figure 203:	Register card „Tools“	247
Figure 204:	PCAP Import.....	247
Figure 205:	PCAP Import.....	248
Figure 206:	Import message "Data for multiple ports"	249
Figure 207:	Import message "Overwrite on import"	249
Figure 208:	Import message "Import failed"	250
Figure 209:	Menu pane "Tools"	251
Figure 210:	Register ESC DL Control (0x0100 to 0x0103).....	254
Figure 211:	Example: miss-interpreted traffic due to enabled automatic direction detection ..	254
Figure 212:	Example: Correct display.....	255
Figure 213:	Example: wrong manual direction	255

List of tables

Table 1:	List of revisions	5
Table 2:	Directory structure of the netANALYZER Scope DVD.....	7
Table 3:	Menu entries of right-side menu	24
Table 4:	Menu Entries of Main Menu.....	25
Table 5:	Menu entries register card Views	26
Table 6:	Color status indicator	32
Table 7:	Options for network speed in port configuration	37
Table 8:	GPIO configuration	38
Table 9:	Buttons of device assignment.....	40
Table 10:	Settings for autonomous operation.....	43
Table 11:	Settings for behavior at overload error	45
Table 12:	Quicktester settings	46
Table 13:	Description of the user interface elements in the dialog Configuration of frame filter - User interface element on the left side	49
Table 14:	Description of the user interface elements in the dialog Configuration of frame filter - User interface element on the right side	50
Table 15:	Predefined Ethernet Frame filters	52
Table 16:	Applicable filter options.....	54
Table 17:	Context menu functions	55
Table 18:	Some common values used for filtering (Line Value)	55
Table 19:	Example: Filter definition	56
Table 20:	Example: Filter definition	56
Table 21:	Buttons for recording control.....	58
Table 22:	Meaning of Elements of EtherCAT Datagram	73
Table 23:	EtherCAT Command Codes	75
Table 24:	List of supported data types for EtherCAT variables	76
Table 25:	Liste der EtherCAT Slave Register	77
Table 26:	Supported PROFINET Data Types.....	78
Table 27:	DCP Events	80
Table 28:	DCE-RPC Events	80
Table 29:	Alarm Events	81
Table 30:	Other Events.....	81
Table 31:	Supported data types for EtherNet/IP variables and constants	83
Table 32:	Icons within the icon bar	90
Table 33:	Display options (filtering)	93
Table 34:	Network description files for use with netANALYZER Scope:	100
Table 35:	Coding of parameter "Physics"	103
Table 36:	Possible selections depending on mode of operation	105
Table 37:	Dialog Variable Wizard - second page	108
Table 38:	Items, superordinate items and appropriate context menus.....	110

Table 39:	Wizards	111
Table 40:	Items and appropriate context menus	112
Table 41:	Assistants	113
Table 42:	Dialog Controller assistant	115
Table 43:	Dialog "Device wizard"	116
Table 44:	Dialog Module wizard– Page 1	119
Table 45:	Dialog Submodule wizard – Page 1	122
Table 46:	Dialog Submodule wizard - page 2 - frame-related aspects	123
Table 47:	Dialog Variable Wizard - first page	125
Table 48:	Dialog Variable Wizard - second page	126
Table 49:	Items, superordinate items and appropriate context menus	128
Table 50:	Items and appropriate context menus	129
Table 51:	Dialog Controller wizard	131
Table 52:	Dialog Device wizard	132
Table 53:	Port segments (Example)	134
Table 54:	Dialog Module wizard– Page 1	136
Table 55:	Dialog Module wizard– Page 2	137
Table 56:	Dialog Module wizard– Page 3	139
Table 57:	Transport classes according to CIP standard	139
Table 58:	Dialog Variable Wizard - first page	140
Table 59:	Dialog Variable Wizard - second page	141
Table 60:	Context menu functions on filter folder level	142
Table 61:	Selection list "Extraction behavior"	144
Table 62:	Meanings of terms in normalization formula	147
Table 63:	Context menu functions on filter level	150
Table 64:	Possible quicktester events within the event log	153
Table 65:	Icons in top bar of filter editor area	161
Table 66:	Test variables in filter definitions, their corresponding test conditions, data types and allowed ranges of values	163
Table 67:	Applicable test conditions / operators	164
Table 68:	Controls in window bar in Chart View	173
Table 69:	Elemente des Export-Dialogs und ihre Bedeutung:	174
Table 70:	Selection options for variable state	177
Table 71:	Auto-scale and hide buttons	181
Table 72:	Chart types	183
Table 73:	Display Points option	183
Table 74:	ChartItemModel subwindow: Option Interpolation	184
Table 75:	Representation of String Values	187
Table 76:	Controls within window bar of trigger view	196
Table 77:	Error message "Trigger configuration is not valid" - Possible causes and suitable remedies (in autonomous operation mode)	199
Table 78:	Applicable signals	202

Table 79:	Function blocks for operations	209
Table 80:	Event-related function blocks.....	210
Table 81:	Detailed additional specifications concerning the communication partners.	226
Table 82:	Columns of event log	229
Table 83:	Possible event types in event protocol	230
Table 84:	MAC addresses of the Master- and Slave-devices within the network.....	231
Table 85:	Structure of ignore list.....	233
Table 86:	Icons for file import	248
Table 87:	Error messages	252
Table 88:	Other error situations	253
Table 89:	Chart data are displayed incorrectly for EtherCAT	254
Table 90:	Example	256

Contacts

HEADQUARTERS

Germany

Hilscher Gesellschaft für
Systemautomation mbH
Rheinstrasse 15
65795 Hattersheim
Phone: +49 (0) 6190 9907-0
Fax: +49 (0) 6190 9907-50
E-mail: info@hilscher.com

Support

Phone: +49 (0) 6190 9907-99
E-mail: de.support@hilscher.com

SUBSIDIARIES

China

Hilscher Systemautomation (Shanghai) Co. Ltd.
200010 Shanghai
Phone: +86 (0) 21-6355-5161
E-mail: info@hilscher.cn

Support

Phone: +86 (0) 21-6355-5161
E-mail: cn.support@hilscher.com

France

Hilscher France S.a.r.l.
69500 Bron
Phone: +33 (0) 4 72 37 98 40
E-mail: info@hilscher.fr

Support

Phone: +33 (0) 4 72 37 98 40
E-mail: fr.support@hilscher.com

India

Hilscher India Pvt. Ltd.
Pune, Delhi, Mumbai
Phone: +91 8888 750 777
E-mail: info@hilscher.in

Italy

Hilscher Italia S.r.l.
20090 Vimodrone (MI)
Phone: +39 02 25007068
E-mail: info@hilscher.it

Support

Phone: +39 02 25007068
E-mail: it.support@hilscher.com

Japan

Hilscher Japan KK
Tokyo, 160-0022
Phone: +81 (0) 3-5362-0521
E-mail: info@hilscher.jp

Support

Phone: +81 (0) 3-5362-0521
E-mail: jp.support@hilscher.com

Korea

Hilscher Korea Inc.
Seongnam, Gyeonggi, 463-400
Phone: +82 (0) 31-789-3715
E-mail: info@hilscher.kr

Switzerland

Hilscher Swiss GmbH
4500 Solothurn
Phone: +41 (0) 32 623 6633
E-mail: info@hilscher.ch

Support

Phone: +49 (0) 6190 9907-99
E-mail: ch.support@hilscher.com

USA

Hilscher North America, Inc.
Lisle, IL 60532
Phone: +1 630-505-5301
E-mail: info@hilscher.us

Support

Phone: +1 630-505-5301
E-mail: us.support@hilscher.com